

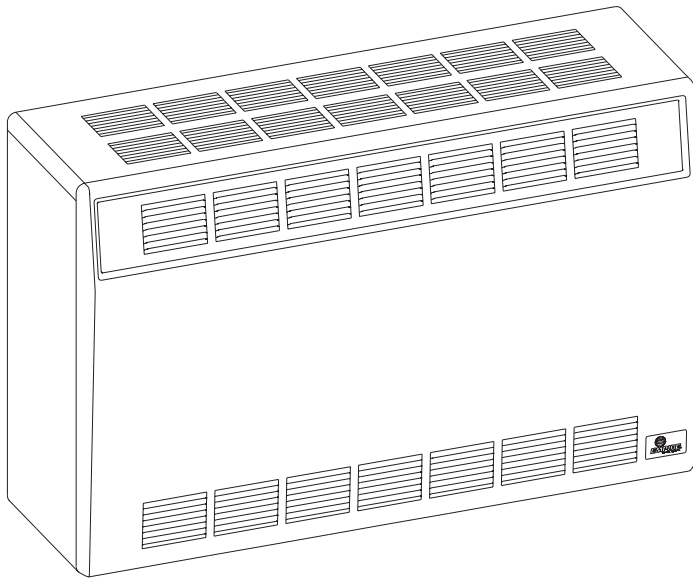

INSTALLATION INSTRUCTIONS AND OWNER'S MANUAL



DIRECT VENT WALL FURNACE

**MODELS
DV-25-2SG
DV-35-2SG**



WARNING: If the information in these instructions are not followed exactly, a fire or explosion may result causing property damage, personal injury or loss of life.

- Do not store or use gasoline or other flammable vapors and liquids in the vicinity of this or any other appliance.
- **WHAT TO DO IF YOU SMELL GAS**
 - Do not try to light any appliance.
 - Do not touch any electrical switch; do not use any phone in your building.
 - Immediately call your gas supplier from a neighbor's phone. Follow the gas supplier's instructions.
 - If you cannot reach your gas supplier, call the fire department.
- Installation and service must be performed by a qualified installer, service agency or the gas supplier.

Installer: Leave this manual with the appliance.

Consumer: Retain this manual for future reference.

This appliance may be installed in an aftermarket, permanently located, manufactured home (USA only) or mobile home, where not prohibited by state or local codes.

This appliance is only for use with the type of gas indicated on the rating plate. This appliance is not convertible for use with other gases, unless a certified kit is used.

WARNING: If not installed, operated and maintained in accordance with the manufacturer's instructions, this product could expose you to substances in fuel or from fuel combustion which can cause death or serious illness.

TABLE OF CONTENTS

SECTION	PAGE
Important Safety Information	3
Safety Information for Users of LP Gas	4
Requirments for Massachusetts	5
Introduction.....	6
Specifications	6
Gas Supply	7
Clearances	8
Installation Instructions.....	8-10
Thermostat Location	10
Lighting Instructions	11
Pilot Flame Characteristics	12
Main Burner Flame Characteristics	12
Maintenance.....	13
Troubleshooting	13
How to Order Repair Parts.....	14
Parts List	14
Parts View	15
Optional Blower Installation Instructions	16-17
Service Notes	18-19

IMPORTANT SAFETY INFORMATION

THIS IS A HEATING APPLIANCE

DO NOT OPERATE THIS APPLIANCE WITHOUT FRONT PANEL INSTALLED.

- Due to high temperatures the appliance should be located out of traffic and away from furniture and draperies.
- Children and adults should be alerted to the hazards of high surface temperatures and should stay away to avoid burns or clothing ignition.
- Young children should be carefully supervised when they are in the same room as the appliance.
- Clothing or other flammable material should not be placed on or near the appliance.
- Any safety screen or guard removed for servicing an appliance must be replaced prior to operating the appliance.
- Keep burner and control compartment clean.
- Vent cap hot while furnace is in operation.
- Installation and repair should be done by a **QUALIFIED SERVICE PERSON**. The appliance should be inspected before use and at least annually by a qualified service person. More frequent cleaning may be required due to excessive lint from carpeting, bedding materials, etc. It is imperative that control compartments, burners and circulating air passageways of the appliance be kept clean.
- **DO NOT** put anything around the furnace that will obstruct the flow of combustion and ventilation air.
- **DO** keep the appliance area clear and free from combustible material, gasoline and other flammable vapors and liquids.
- **DO** examine venting system periodically and replace damaged parts.
- **DO** make a periodic visual check of pilot and burner. Clean and replace damaged parts.
- **CAUTION:** Pilot hole cover must be kept tightly closed during operation.
- **DO NOT** use this heater if any part has been under water. Immediately call a qualified service technician to inspect the heater and to replace any part of the control system and any gas control which has been under water.

SAFETY INFORMATION FOR USERS OF LP-GAS

Propane (LP-Gas) is a flammable gas which can cause fires and explosions. In its natural state, propane is odorless and colorless. You may not know all the following safety precautions which can protect both you and your family from an accident. Read them carefully now, then review them point

by point with the members of your household. Someday when there may not be a minute to lose, everyone's safety will depend on knowing exactly what to do. If, after reading the following information, you feel you still need more information, please contact your gas supplier.

LP-GAS WARNING ODOR

If a gas leak happens, you should be able to smell the gas because of the odorant put in the LP-Gas. That's your signal to go into immediate action!

- Do not operate electric switches, light matches, use your phone. Do not do anything that could ignite the gas.
- Get everyone out of the building, vehicle, trailer, or area. Do that IMMEDIATELY.
- Close all gas tank or cylinder supply valves.
- LP-Gas is heavier than air and may settle in low areas such as basements. When you have reason to suspect a gas leak, keep out of basements and other low areas. Stay out until firefighters declare them to be safe.
- Use your neighbor's phone and call a trained LP-Gas service person and the fire department. Even though you may not continue to smell gas, do not turn on the gas again. Do not re-enter the building, vehicle, trailer, or area.
- **Finally**, let the service man and firefighters check for escaped gas. Have them air out the area before you return. Properly trained LP-Gas service people should repair the leak, then check and relight the gas appliance for you.

NO ODOR DETECTED - ODOR FADE

Some people cannot smell well. Some people cannot smell the odor of the chemical put into the gas. You must find out if you can smell the odorant in propane. Smoking can decrease your ability to smell. Being around an odor for a time can affect your sensitivity or ability to detect that odor. Sometimes other odors in the area mask the gas odor. People may not smell the gas odor or their minds are on something else. Thinking about smelling a gas odor can make it easier to smell.

The odorant in LP-gas is colorless, and it can fade under some circumstances. For example, if there is an underground leak, the movement of the gas through soil can filter the odorant. Odorants

in LP-Gas also are subject to oxidation. This fading can occur if there is rust inside the storage tank or in iron gas pipes.

The odorant in escaped gas can adsorb or absorb onto or into walls, masonry and other materials and fabrics in a room. That will take some of the odorant out of the gas, reducing its odor intensity.

LP-Gas may stratify in a closed area, and the odor intensity could vary at different levels. Since it is heavier than air, there may be more odor at lower levels. Always be sensitive to the slightest gas odor. If you detect any odor, treat it as a serious leak. Immediately go into action as instructed earlier.

SOME POINTS TO REMEMBER

- **Learn to recognize the odor of LP-gas.** Your local LP-Gas Dealer can give you a "Scratch and Sniff" pamphlet. Use it to find out what the propane odor smells like. If you suspect that your LP-Gas has a weak or abnormal odor, call your LP-Gas Dealer.
- If you are not qualified, do not light pilot lights, perform service, or make adjustments to appliances on the LP-Gas system. If you are qualified, consciously think about the odor of LP-Gas prior to and while lighting pilot lights or performing service or making adjustments.
- Sometimes a basement or a closed-up house has a musty smell that can cover up the LP-Gas odor. Do not try to light pilot lights, perform service, or make adjustments in an area where the conditions are such that you may not detect the odor if there has been a leak of LP-Gas.
- Odor fade, due to oxidation by rust or adsorption on walls of new cylinders and tanks, is possible. Therefore, people should be particularly alert and careful when new tanks or cylinders are placed in service. Odor fade can occur in new tanks, or reinstalled old tanks, if they are filled and allowed to set too long before refilling. Cylinders and tanks which have been out of service for a time may develop internal rust which will cause odor fade. If such conditions are suspected to exist, a periodic sniff test of the gas is advisable. If you have any question about the gas odor, call your LP-gas dealer. A periodic sniff test of the LP-gas is a good safety measure under any condition.
- If, at any time, you do not smell the LP-Gas odorant and you think you should, assume you have a leak. Then take the same immediate action recommended above for the occasion when you do detect the odorized LP-Gas.
- If you experience a complete "gas out," (the container is under no vapor pressure), turn the tank valve off immediately. If the container valve is left on, the container may draw in some air through openings such as pilot light orifices. If this occurs, some new internal rusting could occur. If the valve is left open, then treat the container as a new tank. Always be sure your container is under vapor pressure by turning it off at the container before it goes completely empty or having it refilled before it is completely empty.

REQUIREMENTS FOR MASSACHUSETTS

For all side wall horizontally vented gas fueled equipment installed in every dwelling, building or structure used in whole or in part for residential purposes, including those owned or operated by the Commonwealth and where the side wall exhaust vent termination is less than seven (7) feet above finished grade in the area of the venting, including but not limited to decks and porches, the following requirements shall be satisfied:

1. **INSTALLATION OF CARBON MONOXIDE DETECTORS.** At the time of installation of the side wall horizontal vented gas fueled equipment, the installing plumber or gasfitter shall observe that a hard wired carbon monoxide detector with an alarm and battery back-up is installed on the floor level where the gas equipment is to be installed. In addition, the installing plumber or gasfitter shall observe that a battery operated or hard wired carbon monoxide detector with an alarm is installed on each additional level of the dwelling, building or structure served by the side wall horizontal vented gas fueled equipment. It shall be the responsibility of the property owner to secure the services of qualified licensed professionals for the installation of hard wired carbon monoxide detectors
 - a. In the event that the side wall horizontally vented gas fueled equipment is installed in a crawl space or an attic, the hard wired carbon monoxide detector with alarm and battery back-up may be installed on the next adjacent floor level.
 - b. In the event that the requirements of this subdivision can not be met at the time of completion of installation, the owner shall have a period of thirty (30) days to comply with the above requirements; provided, however, that during said thirty (30) day period, a battery operated carbon monoxide detector with an alarm shall be installed.
2. **APPROVED CARBON MONOXIDE DETECTORS.** Each carbon monoxide detector as required in accordance with the above provisions shall comply with NFPA 720 and be ANSI/UL 2034 listed and IAS certified.
3. **SIGNAGE.** A metal or plastic identification plate shall be permanently mounted to the exterior of the building at a minimum height of eight (8) feet above grade directly in line with the exhaust vent terminal for the horizontally vented gas fueled heating appliance or equipment. The sign shall read, in print size no less than one-half (1/2) inch in size, **“GAS VENT DIRECTLY BELOW. KEEP CLEAR OF ALL OBSTRUCTIONS”**.
4. **INSPECTION.** The state or local gas inspector of the side wall horizontally vented gas fueled equipment shall not approve the installation unless, upon inspection, the inspector observes carbon monoxide detectors and signage installed in accordance with the provisions of 248 CMR 5.08(2)(a) 1 through 4.
 - (b) **EXEMPTIONS:** The following equipment is exempt from 248 CMR 5.08(2)(a)1 through 4:
 1. The equipment listed in Chapter 10 entitled “Equipment Not Required To Be Vented” in the most current edition of NFPA 54 as adopted by the Board; and
 2. Product Approved side wall horizontally vented gas fueled equipment installed in a room or structure separate from the dwelling, building or structure used in whole or in part for residential purposes.
 - (c) **MANUFACTURER REQUIREMENTS - GAS EQUIPMENT VENTING SYSTEM PROVIDED.** When the manufacturer of Product Approved side wall horizontally vented gas equipment provides a venting system design or venting system components with the equipment, the instructions provided by the manufacturer for installation of the equipment and the venting system shall include:
 1. Detailed instructions for the installation of the venting system design or the venting system components; and
 2. A complete parts list for the venting system design or venting system.
 - (e) A copy of all installation instructions for all Product Approved side wall horizontally vented gas fueled equipment, all venting instructions, all parts lists for venting instructions, and/or all venting design instructions shall remain with the appliance or equipment at the completion of the installation.

INTRODUCTION

Introduction

Always consult your local Building Department regarding regulations, codes or ordinances which apply to the installation of a direct vent wall furnace.

Instructions to Installer

1. Installer must leave instruction manual with owner after installation.
2. Installer must have owner fill out and mail warranty card supplied with furnace.
3. Installer should show owner how to start and operate furnace and thermostat.

Warning:

Any change to this furnace or its control can be dangerous. This is a heating appliance and any panel, door or guard removed for servicing an appliance must be replaced prior to operating the appliance.

General Information

This furnace is design certified in accordance with American National Standard/CSA Standard Z21.86 and CSA 2.32 by the Canadian Standard Association, as a Gravity Direct Vent Wall Furnace to be installed on an outside wall according to these instructions.

Any alteration of the original design, installed other than as shown in these instructions or use with a type of gas not shown on the rating plate is the responsibility of the person and company making the change.

Important

All correspondence should refer to complete Model No., Serial No. and type of gas.

Notice: During initial firing of this unit, its paint will bake out and smoke will occur. To prevent triggering of smoke alarms, ventilate the room in which the unit is installed.

Installation in Residential Garages

Gas utilization equipment in residential garages shall be installed so that all burners and burner ignition devices are located not less than 18" (457mm) above the floor.

Such equipment shall be located, or protected, so it is not subject to physical damage by a moving vehicle.

Qualified Installing Agency

Installation and replacement of gas piping, gas utilization equipment or accessories and repair and servicing of equipment shall be performed only by a qualified agency. The term "qualified agency" means any individual, firm, corporation or company which either in person or through a representative is engaged in and is responsible for (a) the installation or replacement of gas piping or (b) the connection, installation, repair or servicing of equipment, who is experienced in such work, familiar with all precautions required and has complied with all the requirements of the authority having jurisdiction.

State of Massachusetts: The installation must be made by a licensed plumber or gas fitter in the Commonwealth of Massachusetts.

The installation must conform with local codes or, in the absence of local codes, with the *National Fuel Gas Code ANSI Z223.1/NFPA 54* Natural Gas and Propane Installation Code, CSA B149.1.*

*Available from the American National Standards Institute, Inc., 11 West 42nd St., New York, NY 10036.

High Altitudes

For altitudes/elevations above 2,000 feet (610m), input ratings should be reduced at the rate of 4 percent for each 1,000 (305m) feet above sea level. Canadian High Altitudes for locations having an elevation above mean sea level between 2,000 feet (610m) and 4,500 feet (1370m), the manifold pressure is to be decreased from 4.0" w.c. (.996kPa) to 3.2" w.c. (.796kPa) for Natural Gas and from 10.0" w.c. (2.49kPa) to 8.0" w.c. (1.992kPa) for Propane Gas.

SPECIFICATIONS

Model	DV-25	DV-35
Input BTU/HR (KW/H)	25,000 (7.3)	35,000 (10.3)
Height	27 3/4" (705mm)	27 3/4" (705mm)
Width	37" (940mm)	37" (940mm)
Depth	11 1/2" (292mm)	11 1/2" (292mm)
Gas Inlet (Pipe)	1/2" (13mm)	1/2" (13mm)
Accessories for the Above Furnaces		
Blower Package	DRB-1	DRB-1
Vinyl Siding Vent Kit	DV-822	DV-822

GAS SUPPLY

Locating Gas Supply

The gas line can enter the unit either through the floor or outside wall. The gas line opening should be made at this time. Location of the opening will be determined by the position of floor joists and the valve and union used for servicing.

Recommended Gas Pipe Diameter

Pipe Length	Schedule 40 Pipe Inside Diameter		Tubing, Type L Outside Diameter	
	Nat.	L.P.	Nat.	L.P.
0-10 feet 0-3 meters	1/2"	3/8"	1/2"	3/8"
10-40 feet 4-12 meters	1/2"	1/2"	5/8"	1/2"
40-100 feet 13-30 meters	1/2"	1/2"	3/4"	1/2"
100-150 feet 31-46 meters	3/4"	1/2"	7/8"	3/4"

Note: Never use plastic pipe. Check to confirm whether your local codes allow copper tubing or galvanized.

Note: Since some municipalities have additional local codes, it is always best to consult your local authority and installation code.

The use of the following gas connectors is recommended:

- ANS Z21.24 Appliance Connectors of Corrugated Metal Tubing and Fittings
- ANS Z21.45 Assembled Flexible Appliance Connectors of Other Than All-Metal Construction

The above connectors may be used if acceptable by the authority having jurisdiction. The state of Massachusetts requires that a flexible appliance connector cannot exceed three feet in length.

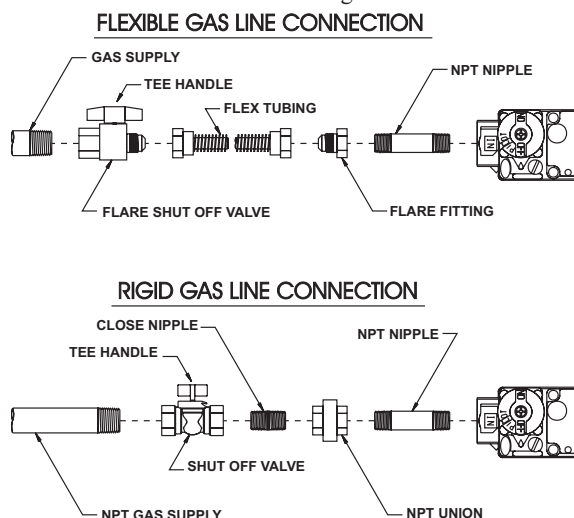

Figure 1

Consult the current National Fuel Gas Code, ANSI Z223.1 CAN/CGA-B149 (.1 or .2) installation code.

Installing a New Main Gas Cock

Each appliance should have its own manual gas cock.

A manual main gas cock should be located in the vicinity of the unit. Where none exists, or where its size or location is not adequate, contact your local authorized installer for installation or relocation.

Compounds used on threaded joints of gas piping shall be resistant to the action of liquefied petroleum gases. The gas lines must be checked for leaks by the installer. This should be done with a soap solution watching for bubbles on all exposed connections, and if unexposed, a pressure test should be made.

Never use an exposed flame to check for leaks. Appliance must be disconnected from piping at inlet of control valve and pipe capped or plugged for pressure test. Never pressure test with appliance connected; control valve will sustain damage!

A gas valve and ground joint union should be installed in the gas line upstream of the gas control to aid in servicing. It is required by the National Fuel Gas Code that a drip line be installed near the gas inlet. This should consist of a vertical length of pipe tee connected into the gas line that is capped on the bottom in which condensation and foreign particles may collect.

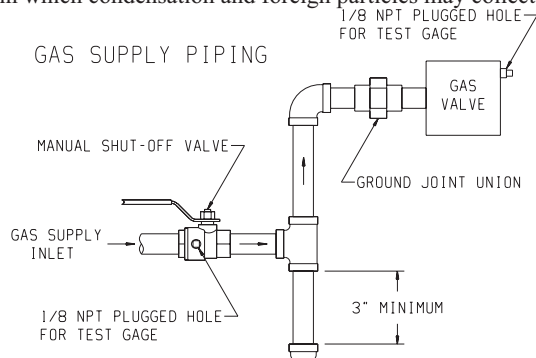

Figure 2

Method of Installing a Tee Fitting Sediment Trap

Pressure Testing of the Gas Supply System

1. To check the inlet pressure to the gas valve, a 1/8" (3mm) N.P.T. plugged tapping, accessible for test gauge connection, must be placed immediately upstream of the gas supply connection to the appliance.
2. The appliance and its individual shutoff valve must be disconnected from the gas supply piping system during any pressure testing of that system at test pressures in excess of 1/2 psig (3.5 kPa).
3. The appliance must be isolated from the gas supply piping system by closing its individual manual shutoff valve during any pressure testing of the gas supply piping system at test pressures equal to or less than 1/2 psig (3.5 kPa).

Attention! If one of the above procedures results in pressures in excess of 1/2 psig (14" w.c.) (3.5 kPa) on the appliance gas valve, it will result in a hazardous condition.

Checking Manifold Pressure

Both Propane and Natural gas valves have a built-in pressure regulator in the gas valve. Natural gas models will have a manifold pressure of approximately 4.0" w.c. (.996kPa) at the valve outlet with the inlet pressure to the valve from a minimum of 5.0" w.c. (1.245kPa) for the purpose of input adjustment to a maximum of 10.5" w.c. (2.61kPa). Propane gas models will have a manifold pressure approximately 10.0" w.c. (2.49kPa) at the valve outlet with the inlet pressure to the valve from a minimum of 11.0" w.c. (2.739kPa) for the purpose of input adjustment to a maximum of 13.0" w.c. (3.237kPa).

A 1/8" (3mm) N.P.T. plugged tapping, accessible for test gauge connection, is located on the outlet side of the gas control.

CLEARANCES

1. In selecting a location for installation, it is necessary to provide adequate accessibility clearances for servicing and proper installation.
2. Unit is supported by a wall bracket secured to the wall.
3. The minimum clearances from casing to combustible construction is 48" (121cm) on top, 6" (152mm) on each side and 4" (102mm) from the floor or from the top surface of carpeting, tile or other floor covering and 0" (0mm) to rear wall.
4. The minimum distance from the center of the vent cap to the nearest outside corner or obstruction is 24" (610mm).
5. The DV-25 and DV-35 minimum wall depth is 4 1/2" (114mm) (and the maximum is 13" (330mm)). The use of tubes not supplied by the manufacturer results in unsatisfactory performance.

The vent terminal of a direct vent appliance, with an input of 50,000 (14.6 KW) BTU per hour or less shall be located at least 9" (229mm) from any opening through which flue gases could enter a building. The bottom of the vent terminal and the air intake shall be located at least 12" (305mm) above grade.

WARNING: The nearest point of the vent cap should be a minimum horizontal distant of six (6) (1.83m) feet from any pressure regulator. In case of regulator malfunction, the six (6) (1.83m) feet distance will reduce the chance of gas entering the vent cap.

INSTALLATION INSTRUCTIONS

Location of Furnace

Pick a location on an outside wall with a clear space of 28" (711mm) high by 49" (124cm) wide in the room.

Locating Wall Opening

The furnace is to be located on an outside wall. Locate wall studs so that wall opening will be located between wall studs. The wall studs can be used for attachment of wall mounting bracket. The wall opening required as shown in Figure 3 is a diameter of 7 1/2 inches (191mm).

A template is provided in furnace carton for positioning furnace on the wall. Also, refer to Figure 3 for positioning the furnace on wall and for locating gas line connection.

Figure 3 will position the furnace four inches (102mm) off the floor. If it is desired to position the furnace higher on the wall, add the difference to the "A," "B" and "C" dimensions.

Note: The vent opening is not in the center of the furnace.

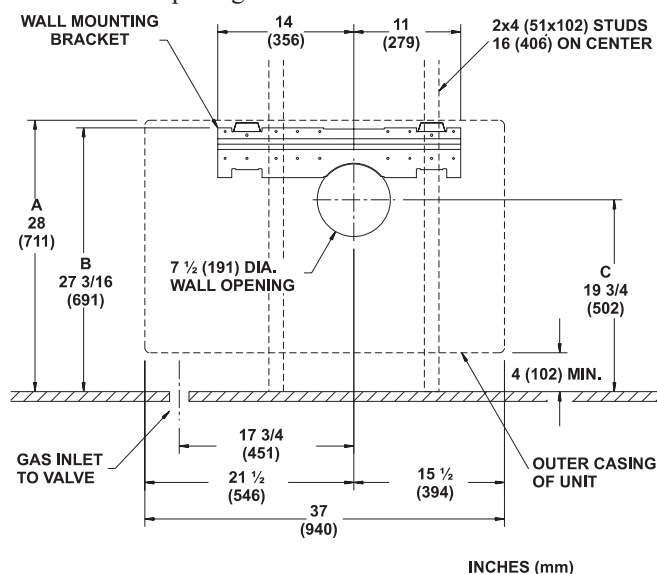

Figure 3

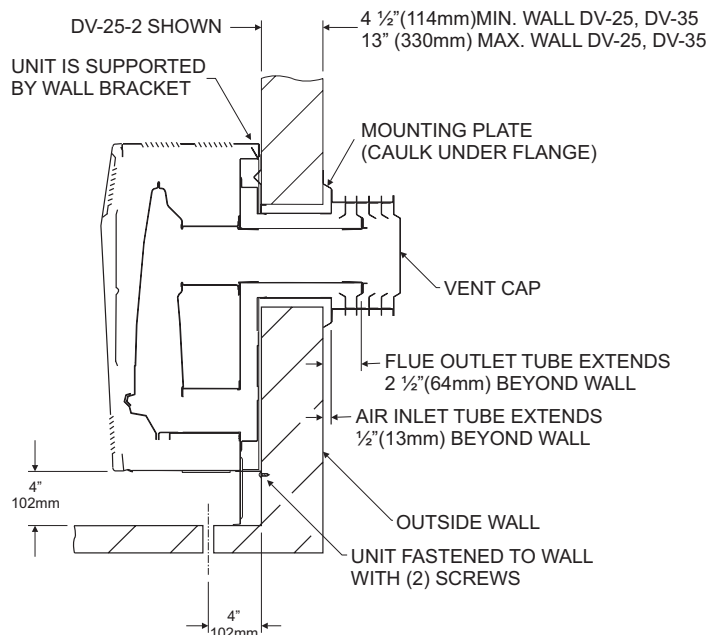

Figure 4

Installing Wall Mounting Bracket

Locate and cut wall opening. If there is insulation above the wall opening (air inlet tube) a barrier should be installed above the wall opening (air inlet tube) to prevent insulation from coming in contact with the air inlet tube. The barrier must not penetrate into the 7 1/2" (191mm) diameter wall opening. Place the flat surface of the wall mounting bracket toward the wall. Insert half round flange of wall mounting bracket into and at the top of the wall opening. The half round flange of the wall mounting bracket must be in contact with the sheetrock or wood at the top of the wall opening. Level the wall mounting bracket in the wall opening.

INSTALLATION INSTRUCTIONS (continued)

On solid wall, when using wall studs for attachment of wall mounting bracket, fasten wall mounting bracket to wall studs with (2) #10 x 1 1/2" (38mm) screws provided and fasten (2) additional #10 x 1 1/2" (38mm) screws provided through the wall mounting bracket and into the solid wall.

On sheet rock, when using wall studs for attachment of wall mounting bracket, fasten wall mounting bracket to wall studs with (2) #10 x 1 1/2" (38mm) screws provided and by using wall opening for access, fasten 2 additional #10 x 1 1/2" (38mm) screws and (2) Tinnerman nuts provided through the wall mounting bracket and into the sheet rock.

Attaching Furnace To Wall Mounting Bracket

Hang furnace on wall mounting bracket by aligning (2) tabs on wall mounting bracket with (2) slots located on inner casing top.

The inner casing bottom is to be fastened to the wall. On solid wall, fasten inner casing bottom with (2) #10 x 1 1/2" (38mm) screws provided. On sheet rock wall, fasten inner casing bottom with (2) toggle bolts provided.

Cutting Vent Tubes

This is the most important part of the installation. With the furnace installed on wall the 6" (152mm) diameter air inlet tube and the 4" (102mm) diameter flue outlet tube are to be marked and cut using the following procedure.

1. Attach 6" (152mm) diameter air inlet tube onto the collar of air drop assembly. Be sure 6" (152mm) diameter air inlet tube is placed as far as possible onto the collar of the air drop assembly. Mark the 6" (152mm) diameter air inlet tube 1/2" (13mm) beyond the outside wall. Remove 6" (152mm) diameter air inlet tube from collar of air drop assembly.
2. Attach 4" (102mm) diameter flue outlet tube onto flue outlet collar on combustion chamber. Be sure 4" (102mm) diameter flue outlet tube is placed as far as possible onto the collar of flue outlet. Mark the 4" (102mm) diameter flue outlet tube 2 1/2" (64mm) beyond the outside wall. Remove 4" (102mm) diameter flue outlet tube from collar of flue outlet on combustion chamber.
3. Mark or wrap tape completely around the tubes at the marked points to help in making a true cut. Do not crimp or enlarge tubes.

Installing Vent Assembly

1. Place provided caulking beneath the edge of the outside mounting plate. Use additional caulking to correct uneven wall surface, such as clapboard.
2. Attach 6" (152mm) diameter air inlet tube onto the collar of air drop assembly. Attach caulked, outside mounting plate into the 6" (152mm) diameter air inlet tube. Position the outside mounting plate so that 6" (152mm) diameter air inlet tube has a slight downward slope to the outside. The downward slope is necessary to prevent the entry of rainwater. Attach outside mounting plate to exterior wall with (4) #10 x 1 1/2" (38mm) screws provided.
3. Apply furnace cement to 4" (102mm) diameter flue outlet collar on combustion chamber and to 4" (102mm) diameter collar on vent cap. Attach 4" (102mm) diameter flue outlet tube onto flue outlet collar on combustion chamber. Attach vent cap into the

- 4" (102mm) diameter flue outlet tube. Attach vent cap to outside mounting plate with (3) #10 x 1/2" (13mm) screws provided.
4. Installation is completed.

Reassembly And Resealing Vent-Air Intake System

When vent-air intake system is removed for servicing the furnace, the following steps will assure proper reassembly and resealing of the vent-air intake assembly.

1. Remove old furnace cement from flue outlet collar on combustion chamber and collar of vent cap. Remove old furnace cement from both ends of 4" (102mm) diameter flue outlet tube.
2. Remove old caulking beneath the edge of the outside mounting plate. Apply new caulking beneath the edge of the outside mounting plate. Use additional caulking to correct uneven wall surface, such as clapboard.
3. Attach 6" (152mm) diameter air inlet tube onto the collar of air drop assembly. Attach caulked, outside mounting plate into the 6" (152mm) diameter air inlet tube. Position the outside mounting plate so that 6" (152mm) diameter air inlet tube has a slight downward slope to the outside. The downward slope is necessary to prevent the entry of rainwater. Attach outside mounting plate to exterior wall with (4) #10 x 1 1/2" (38mm) screws provided.
4. Apply furnace cement to 4" (102mm) diameter flue outlet collar on combustion chamber and to 4" (102mm) diameter collar on vent cap. Attach 4" (102mm) diameter flue outlet tube onto flue outlet collar on combustion chamber. Attach vent cap into the 4" (102mm) diameter flue outlet tube. Attach vent cap to outside mounting plate with (3) #10 x 1/2" (13mm) screws provided.
5. Reassembly and resealing vent-air intake system is completed.

Installing a Vent Near a Window Ledge, Other Type of Projection or on Siding (vinyl, aluminum, etc.)

Direct vent furnaces are designed to be installed on a uniform outside wall. When the wind comes from any angle (up, down or from either side), it must hit the vent cap equally over both the air inlet and the flue outlet portions of the vent. Any wall projection, such as a door or window casing, which disturbs the wind on one side of the air inlet section will result in back pressure on the flue section smothering the flame and eventual pilot outage.

When the vent cap is to be installed on siding or it appears that a projection within 6" (152mm) of any side of the air inlet section could shield the air inlet section, the entire vent should be supported away from the wall at least the distance of the projection. 2" x 4" (51mm x 102mm) framing whose outside dimensions match the overall dimensions of the mounting plate is recommended. The 2" x 4" (51mm x 102mm) framing protects siding from possible warpage or discoloration. All joints can then be sealed and painted. The wall depth plus the additional depth of the 2" x 4" (51mm x 102mm) framing should not exceed a total depth of 13" (330mm) for DV-25 and DV-35. (See Figure 5)

Vinyl siding vent kit, DV-822, is available from Empire Comfort Systems, Inc. The depth is 3" (76mm), which enables the vent cap to be extended away from siding or projections. The wall depth plus the additional 3" (76mm) depth of the vinyl siding vent cap extension should not exceed a total depth of 13" (330mm) for DV-25 and DV-35. (See Figure 5a)

Warning: When vinyl siding vent kit, DV-822 or 2" x 4" (51mm x 102mm) framing is added to an existing installation (furnace is installed) do not attempt to add sections of pipe to the flue outlet tube or air inlet tube. An air tight seal is required for both tubes. Refer to Parts List, page 14 to order tubes.

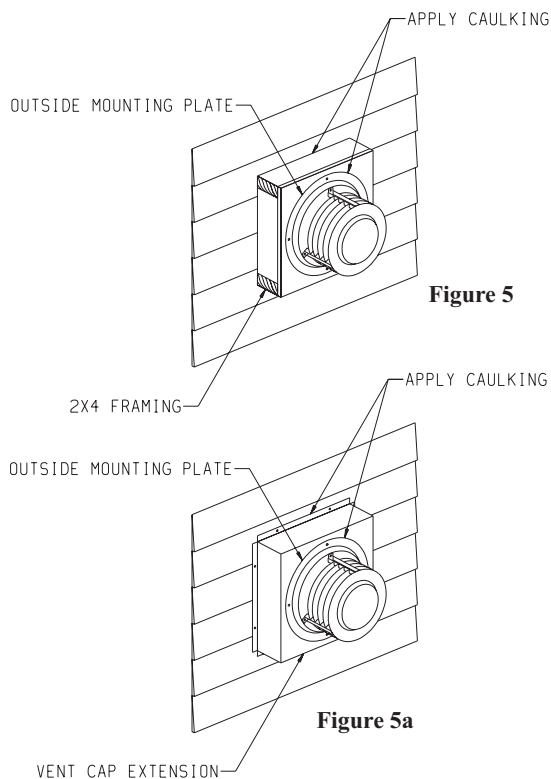

THERMOSTAT LOCATION

Millivolt wall thermostats are specially designed for use on self-generating systems. They should never be used on line or low voltage A.C. circuits.

Interior Wall — The thermostat should be installed on an inside wall away from the furnace but in the same room.

It is important to use wire of a gauge proper for the length of the wire:

RECOMMENDED WIRE GAUGES	
Maximum Length	Wire Gauge
1' to 10'	18
10' to 25'	16
25' to 35'	14

Proper operation depends on a good pilot flame. The flame must cover the top of the thermopile. Cleaning of the pilot orifice and burner may be required due to spiders.

System Check (Figure 6)

A millivolt meter is required to check the system. Millivolt readings should be:

- Across the thermopile terminals, 400-450 millivolts with thermostat OFF.
- Across the thermopile terminals, 150-250 millivolts with thermostat ON.
- Across the thermostat wires at the valve, less than 30 millivolts with thermostat ON.
- Across the thermostat wires at the thermostat, less than 5 millivolts with thermostat ON. (Strong winds, dirty pilot and low pressure will reduce readings.)

Piezo Pilot Ignitor Instructions

Depressing the red button completely causes a spark to occur at the pilot. This is a substitute for a match which requires opening the pilot hole cover.

To light the pilot, it is important that the electrode be 1/8" (3mm) from the thermopile. The spark must occur at the point the burner flame hits the thermopile. The end of the electrode will be red hot with the pilot on.

On a new installation with air in the gas line, it is suggested that a match be used. The match will light the pilot faster than the piezo under this condition.

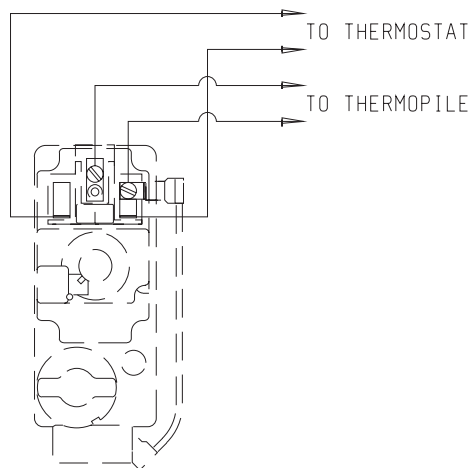

Figure 6

LIGHTING INSTRUCTIONS

FOR YOUR SAFETY READ BEFORE LIGHTING

WARNING: If you do not follow these instructions exactly, a fire or explosion may result causing property damage, personal injury or loss of life.

- A. This appliance has a pilot which must be lighted by hand. When lighting the pilot, follow these instructions exactly.
- B. BEFORE LIGHTING smell all around the appliance area for gas. Be sure to smell next to the floor because some gas is heavier than air and will settle on the floor.
WHAT TO DO IF YOU SMELL GAS
 - Do not try to light any appliance.
 - Do not touch any electrical switch; do not use any phone in your building.
 - Immediately call your gas supplier from a neighbor's phone. Follow the gas supplier's instructions.
 - If you cannot reach your gas supplier, call the fire department.
- C. Use only your hand to push in or turn the gas control knob. Never use tools. If the knob will not push in or turn by hand, don't try to repair it; call a qualified service technician. Force or attempted repair may result in a fire or explosion.
- D. Do not use this appliance if any part has been under water. Immediately call a qualified service technician to inspect the appliance and to replace any part of the control system and any gas control which has been under water.

LIGHTING INSTRUCTIONS

1. STOP! Read the safety information above.
2. Set the thermostat to lowest setting.
3. Turn off all electric power to the appliance (if applicable).
4. Remove casing front assembly.
5. Push in gas control knob slightly and turn clockwise to "OFF".
9. Turn knob on gas control counterclockwise to "PILOT".
10. Push in control knob all the way and hold in. Immediately light the pilot with the Piezo Pilot Ignitor or a match. Continue to hold the control knob in for about one (1) minute after the pilot is lit. Release knob, and it will pop back up. Pilot should remain lit. If it goes out, repeat steps 5 through 10.



NOTE: Knob cannot be turned from "PILOT" to "OFF" unless knob is pushed in slightly. Do not force.

6. Wait ten (10) minutes to clear out any gas. Then smell for gas, including near the floor. If you smell gas, STOP! Follow "B" in the safety information above. If you don't smell gas, go to the next step.
7. Remove the pilot access cover located on the combustion chamber.
8. Find pilot - follow metal tube
11. Replace pilot access cover.
12. Turn gas control knob counterclockwise to "ON".
13. Replace casing front assembly.
14. Turn on all electric power to the appliance (if applicable).
15. Set thermostat to desired setting.
16. CAUTION: Pilot access cover must be kept tightly closed during operation.

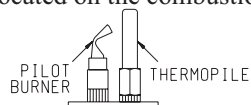

TO TURN OFF GAS TO APPLIANCE

1. Set the thermostat to lowest setting.
2. Turn off all electric power to appliance if service is to be performed (if applicable).
3. Remove casing front assembly.
4. Push in gas control knob slightly and turn clockwise to "OFF." Do not force.
5. Replace casing front assembly.

PILOT FLAME CHARACTERISTICS

The correct flame will be almost horizontal, blue and will extend past the thermopile 1/4" (6mm). The flame will surround the thermopile just below the tip.

On propane (LP-gas) slight yellow might occur where the pilot flame and burner flame meet.

Natural gas pilots require adjusting when the inlet pressure is above 5" w.c. (1.25kPa) Turn adjustment screw clockwise to reduce flame.

Propane (LP-gas) will not require adjusting.

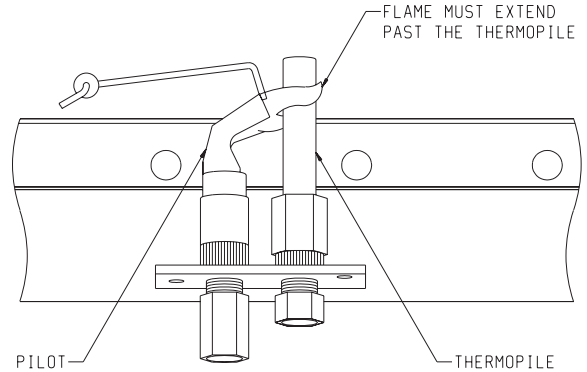

Figure 7

MAIN BURNER FLAME CHARACTERISTICS

There will be a short blue inner flame with a much larger lighter blue secondary flame. The burner flame may have a yellow tip when hot. See the burner drawing showing the approximate heights of each part of the flame. Dust in the combustion air will produce an orange or red flame. Do not mistake the orange or red flame for an improper yellow flame. After use, cleaning may be required for the proper flame.

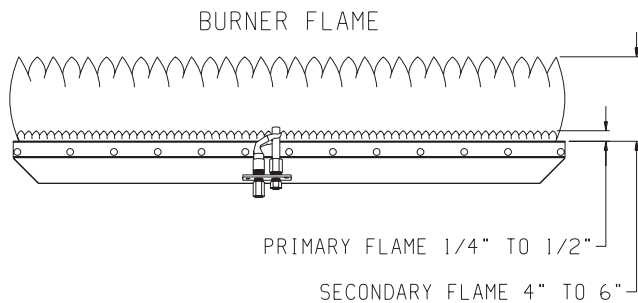

Figure 8

Primary Air Adjustment (Figure 9)

An air adjustment bolt is located on the chamber support bottom. The four inch (102mm) clearance between the furnace and the floor allows access to the air adjustment bolt. The air adjustment bolt is above the rectangular opening on the inner casing bottom.

On Propane gas, if a whistling noise (resonance) occurs, screw air adjustment bolt into the chamber support in order to reduce the

amount of primary air. If the whistling noise (resonance) is not eliminated when the air adjustment bolt is screwed into the chamber support this may indicate the air adjustment bolt is misaligned. Grasp air adjustment bolt and pivot (push) air adjustment bolt away from yourself. Observe the main burner flame as you push air adjustment bolt and when the main burner flame begins to develop a yellow flame, you should stop pushing on the air adjustment bolt. Screw air adjustment bolt out of the chamber support until the yellow flame on the main burner is eliminated. The air adjustment bolt should now be properly aligned. The reduction in primary air will soften the main burner flame and will eliminate the whistling noise (resonance).

On Propane or Natural gas, if a yellow flame occurs, screw air adjustment bolt out of the chamber support but do not completely remove air adjustment bolt from chamber support. The repositioning of the air adjustment bolt will increase the amount of primary air. The increase in primary air will sharpen the main burner flame and will eliminate the yellow flame.

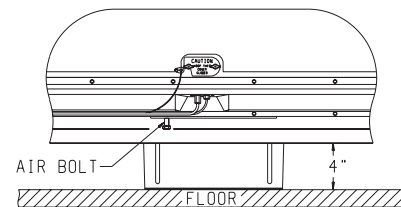

Figure 9

MAINTENANCE

Removing Main Burner

1. Disconnect the thermopile and pilot supply line at the pilot burner.
2. Remove the burner compartment cover.
3. Remove orifice shield.
4. Remove bolt on each side of burner and lift out.

Cleaning Main Burner

The main burner may be cleaned by forcing water into the ports and the throat of the burner. The main burner should be blown dry or heated to remove water from main burner.

Removing Main Burner Orifice

1. Open the brass union located after the gas valve.
2. Loosen valve bracket.
3. Remove the 3/8" (10mm) manifold pipe that is attached to the union elbow until the manifold pipe is free.
4. The main burner orifice is at the end of the manifold pipe.

Removing Pilot Orifice

1. Disconnect the pilot supply line at the pilot burner.
2. Remove pilot orifice from pilot burner. It may be necessary to tap on pilot burner in order to remove the pilot orifice.

Cleaning Pilot Orifice

After use, cleaning of the pilot burner may be required for the proper flame. Also, cleaning of the pilot burner may be required due to spiders (spider webs). The pilot orifice can be cleaned with high pressure air or by placing under running water. Pilot orifice must be dry before replacement. Use a pipe cleaner to clean inside the pilot after the pilot orifice has been removed.

Cleaning Combustion Chamber

When the main burner and vent cap are removed, all internal areas of the combustion chamber are accessible for cleaning with a vacuum hose.

TROUBLESHOOTING

1. Lit match goes out as it enters lighter port.
 - a. Certain wind conditions will blow out match. Ignite match, and as it flares, thrust match through opening.
 - b. Open nearby door or window and relight pilot.
2. Pilot flames but goes out when knob is released.
 - a. See Lighting Instructions. Relight Pilot.
 - b. Relight the pilot and hold knob down longer and harder. Close lighter hole cover just after igniting. Check for a good pilot flame.
 - c. Defective thermopile or defective magnet in safety section of valve. Replace.
3. Yellow pilot flame
 - a. Obstruction at pilot orifice.
 - b. Clean pilot orifice.
4. Pilot and main burner go out during normal operation.
 - a. Check millivolts.
 - b. Check for proper size of pilot flame.
 - c. Check for defective or weak thermopile.
 - d. Check input, reduce as needed.
 - e. Cover on pilot lighter hole must be air tight.
 - f. Check for tight fit of air and flue tubes at both ends of vent assembly. No obstruction around vent that would prevent the wind from hitting all of the vent equally.
5. Thermostat does not turn the main burner on.
 - a. Check wiring.
 - b. Check all millivolt readings.
 - c. Check for spider in main burner orifice.
6. Yellow main burner flame soot on the vent cap.
 - a. See Page 12, "Primary Air Adjustment".
 - b. Remove main burner to check for obstructions in throat and ports.
 - c. Install new main burner orifice and pilot orifice. Refer to Parts List, page 14.
7. On Propane gas, if a whistling noise (resonance) occurs.
 - a. See Page 12, "Primary Air Adjustment".
 - b. Reduce manifold pressure.
 - c. Size main burner orifice with a drill bit. For DV-25 use #54 drill bit. For DV-35 use #50 drill bit.

HOW TO ORDER REPAIR PARTS

Parts can be ordered only through your **service person or dealer**. For best results, the **service person or dealer** should order parts through the distributor. Parts can be shipped directly to the **service person/dealer**.

All parts listed in the **Parts List** have a **Part Number**. When ordering parts, first obtain the **Model Number** from the name plate on your equipment. Then determine the Part Number (**not** the Index Number) and the Description of each part from the following appropriate illustration and list. Be sure to give all this information.

Furnace Model Number _____ Part Description _____

Furnace Serial Number _____ Part Number _____

Type of Gas (Propane or Natural) _____

Do not order bolts, screws, washers or nuts. They are standard hardware items and can be purchased at any local hardware store.

Shipments contingent upon strikes, fires and all causes beyond our control.

Empire Comfort Systems, Inc. Nine Eighteen Freeburg Ave. Belleville, IL 62222-0529

PARTS LIST

PLEASE NOTE: When ordering parts, it is very important that part number and description of part coincide.

Index No.	Part Number	Description	Index No.	Part Number	Description
1	DV-769	Vent Cap	24	DV-994	Pilot Shield
2	DV-131	Outside Mounting Plate	25	R-2224	Pilot Burner with Orifice (Nat)
3	DV-548	Air Inlet Tube	25	R-2223	Pilot Burner with Orifice (LP)
4	DV-524	Flue Outlet Tube	26	DV-772	Electrode and Wire
5	DV-757	Vent Kit	27	DV-913	Casing Front
6	DV-899	Wall Mounting Bracket	28	742155	Burner Orifice, (DV-25 Nat)
7	DV-900	Inlet Air Drop Chute	28	742238	Burner Orifice, (DV-25 LP)
8	DV-762	Gasket - Air Drop Chute	28	P-86-38	Burner Orifice, (DV-35 Nat)
	& DV-763	(2 Each Required)	28	742233	Burner Orifice, (DV-35 LP)
9	DV-951	Casing Top	29	P-190	Manifold
10	DV-901	Heat Shield	30	R-191	Manifold Union Assembly
11	DV-902	Inner Casing (US version)	31	R-5600	Gas Valve (Nat) 7000 MVRLC
11	15665	Inner Casing (Canada version)	31	R-5601	Gas Valve (LP) 7000 MVRLC
12	RH-705	Casing Side (2 Required)	32	DV-1003	Valve Bracket
13	712036	Gasket - Flue Outlet Support	33	DV-764	Gasket - Chamber Support
14	DV-903	Combustion Chamber (DV-25)		& DV-765	(2 Each Required)
14	DV-904	Combustion Chamber (DV-35)	34	DV-908	Valve Shield
15	712098	Gasket - Lighting Hole	35	R-2313	Piezo Ignitor
16	DV-781	Lighting Hole Cover Assembly with Clear Mica	Not Shown	742158	Pilot Orifice (Nat)
17	DV-064	Cover Plate	Not Shown	742266	Pilot Orifice (LP)
18	DV-988	Burner (DV-25)	Not Shown	662021	Wall Thermostat - Millivolt
18	DV-990	Burner (DV-35)	Not Shown	DV-885	Hardware Package
19	672063	Thermopile	Not Shown	922113	Operator Section - Nat
20	DV-1004	Pilot Tubing w/Ferrells	Not Shown	922217	Operator Section - LP
21	RH-238	Burner Door	Not Shown	652121	Regulator - Nat
22	DV-778	Gasket - Burner Door	Not Shown	652211	Regulator - LP
23	712051	Gasket - Pilot Burner	Not Shown	13298	Thermostat Bracket

USE ONLY MANUFACTURER'S REPLACEMENT PARTS. USE OF ANY OTHER PARTS COULD CAUSE INJURY OR DEATH.

PARTS VIEW

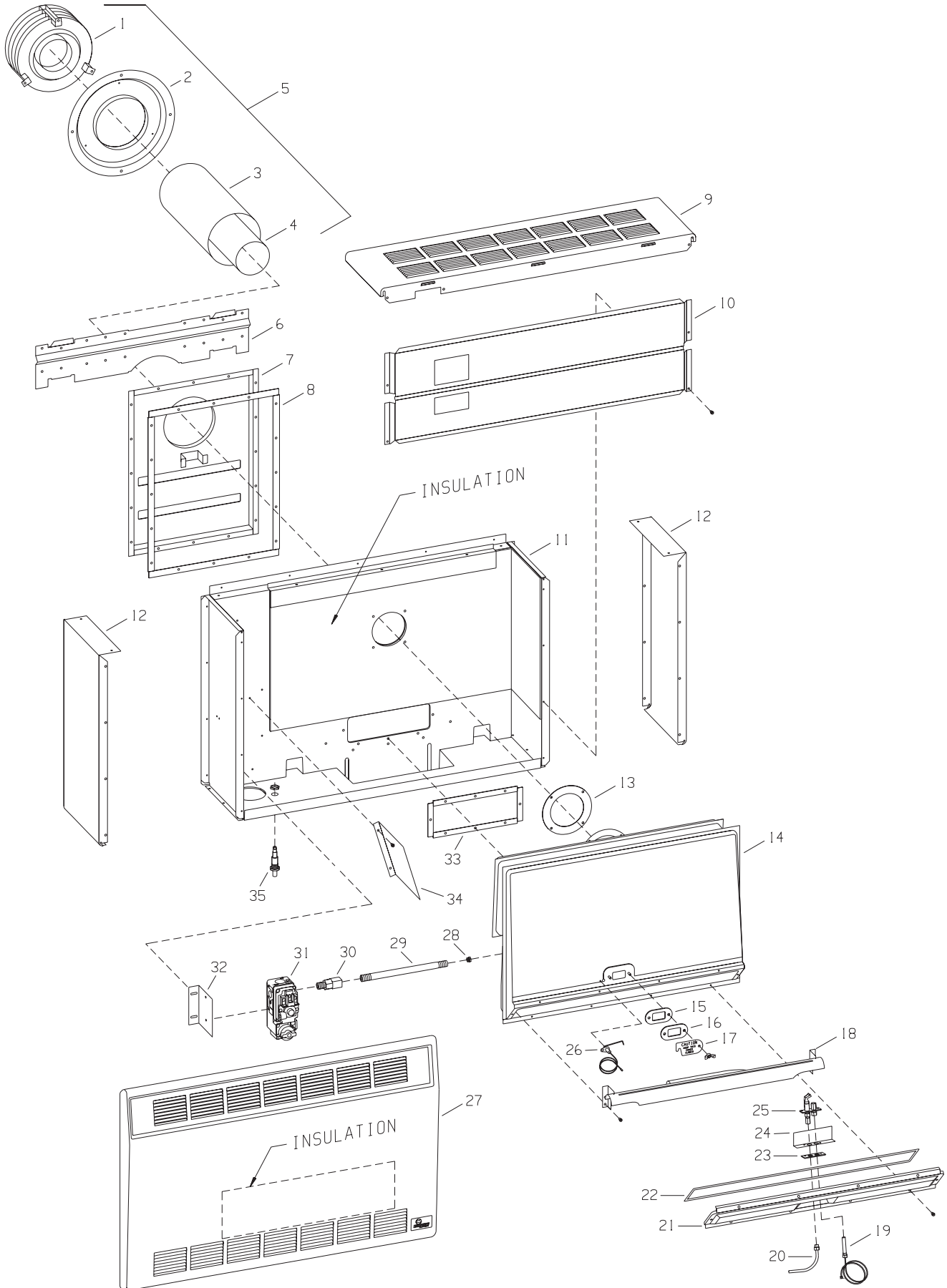

OPTIONAL BLOWER INSTALLATION INSTRUCTIONS

OPTIONAL BLOWER DRB-1

Vented Room Heaters RH-25-(1, 2, 4, 5, 6) and RH-35-(1, 2, 4, 5, 6) Direct Vent Wall Furnaces DV-25-(1, 2)SG and DV-35-(1, 2)SG

Installing Optional DRB-1 Blower

1. For RH-25-(1, 2, 4, 5, 6) and RH-35-(1, 2, 4, 5, 6), remove casing front.
1. For DV-25-(1, 2)SG and DV-35-(1, 2)SG, remove casing front and heat shield.
2. When facing appliance, insert blower assembly into the left section of the casing (adjacent to the combustion chamber).
3. For RH-25-(1, 2, 4, 5, 6) and RH-35-(1, 2, 4, 5, 6), route cord set through opening in casing back. The opening in casing back is located adjacent to gas control.
3. For DV-25-(1, 2)SG and DV-35-(1, 2)SG, route cord set through opening in casing bottom. The opening in casing bottom is located beneath gas control.
4. Align the (2) screw holes on the inner side panel and the (2) screw holes on casing back with the (4) clearance holes on the blower assembly. Attach blower assembly to the casing back and inner side panel with (4) #10 x 1/2" (13mm) screws provided. The blower assembly must be attached first to the casing back and then to the casing side panel.
5. For RH-25-(1, 2, 4, 5, 6) and RH-35-(1, 2, 4, 5, 6), replace casing front.
5. For DV-25-(1, 2)SG and DV-35-(1, 2)SG, replace heat shield and casing front.

Attention: Wiring harness on blower is factory assembled and installed. If wiring harness becomes disassembled use the following steps to reassemble the wiring harness.

1. Attach (1) pin terminal from black (hot) wire, smooth insulation on cord set to (1) socket terminal on fan control assembly.
2. Attach (1) pin terminal from black (neutral) wire, ribbed insulation on cord set to (1) socket terminal from white (neutral) wire on motor.
3. Attach (1) pin terminal on fan control assembly to (1) socket terminal from black (hot) wire on motor.
4. Attach green ground wire beneath one of the #10 x 1/2" (13mm) screws on the blower housing.

Fan Control

The automatic fan control is located in the switch box. The switch box is attached to the front of the blower assembly. The switch box is adjacent to the combustion chamber. The fan control is a non-adjustable automatic type. The fan control will require between 5 and 10 minutes of main burner operation before the fan control "closes" and activates the blower. The blower will continue to run between 5 and 10 minutes after the main burner shuts off, before the fan control "opens" and deactivates the blower.

Wiring

The appliance, when installed, must be electrically grounded in

accordance with local codes or, in the absence of local codes, with the National Electrical Code, ANSI/NFPA 70 or Canadian Electrical Code, CSA C22.1, if an external electrical source is utilized. This appliance is equipped with a three-prong [grounding] plug for your protection against shock hazard and should be plugged directly into a properly grounded three-prong receptacle. Do not cut or remove the grounding prong from this plug. For an ungrounded receptacle, an adapter, which has two prongs and a wire for grounding, can be purchased, plugged into the ungrounded receptacle and its wire connected to the receptacle mounting screws. With this wire completing the ground, the appliance cord plug can be plugged into the adapter and be electrically grounded.

CAUTION: Label all wires prior to disconnection when servicing controls. Wiring errors can cause improper and dangerous operation. Verify proper operation after servicing.

WARNING: Unplugging of blower accessory will not stop the heater from cycling. To shut heater off: Turn temperature dial or thermostat to lowest setting. Turn knob on gas control to "OFF", depressing slightly. Do not force.

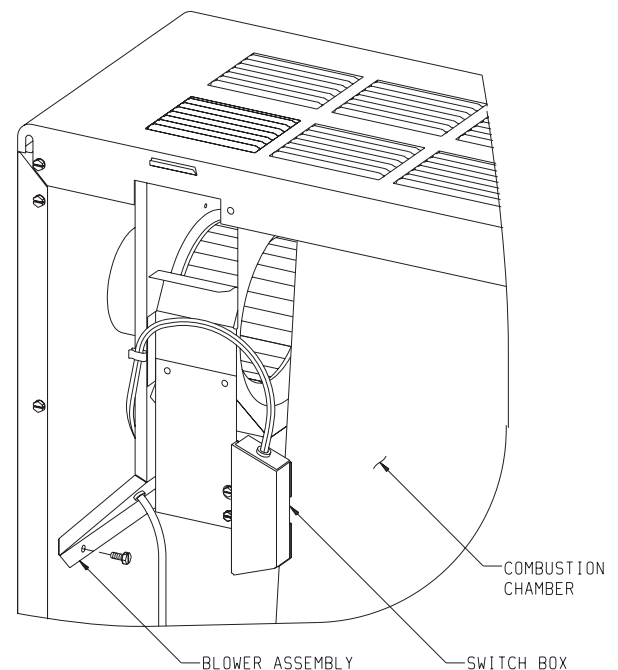

OPTIONAL BLOWER INSTALLATION INSTRUCTIONS (continued)

Cleaning

The blower wheel will collect lint and could require cleaning once a year. If the air output decreases or the noise level increases, it indicates a dirty wheel. Complete removal of the wheel and scrubbing it with a brush under flowing water is recommended.

Oiling

The blower motor has an oil hole located on each end of the motor. Use #20 motor oil only. It is best to oil the motor several times during the heating season using 2 or 3 drops each time. If the motor fails to start and hums, it could be a tight bearing due to lack of oil. This may be corrected by pouring kerosene in the oil holes, allowing to stand for a few hours and then oiling properly.

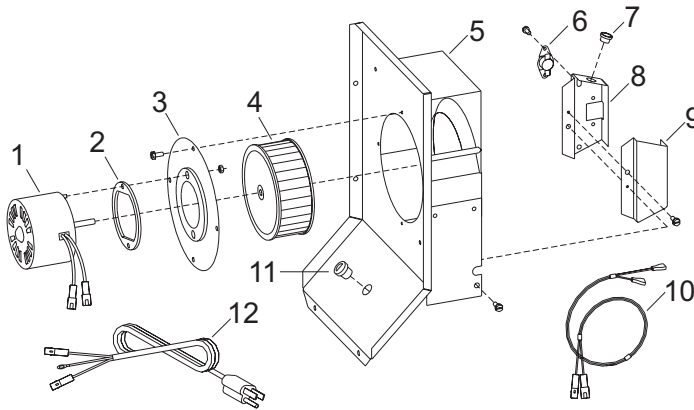

PARTS LIST

Index No.	Part No.	Description
1	R-2090	Motor
2	632016	Motor Cushion
3	RH-036	Motor Support
4	642030	Blower Wheel
5	RH-710	Blower Housing Assembly
6	9120106	Fan Control Switch
7	872087	Heyco Bushing
8	DV-806	Switch Box
9	DV-807	Switch Box Cover
10	R-2091	Wire Assembly 19" (483mm)
11	8720161	Heyco Bushing
12	R-2099	Cord Set 72" (1.83m)

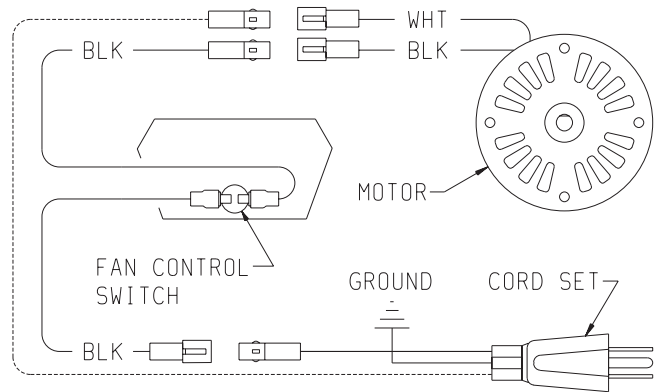

————— BLACK HOT-SMOOTH INSULATION
 - - - - - BLACK NEUTRAL-RIBBED INSULATION

IF ANY OF THE ORIGINAL WIRE AS SUPPLIED WITH THIS UNIT MUST BE REPLACED, IT MUST BE REPLACED WITH 125°C 2/64 INSULATION WIRE OR ITS EQUIVALENT.

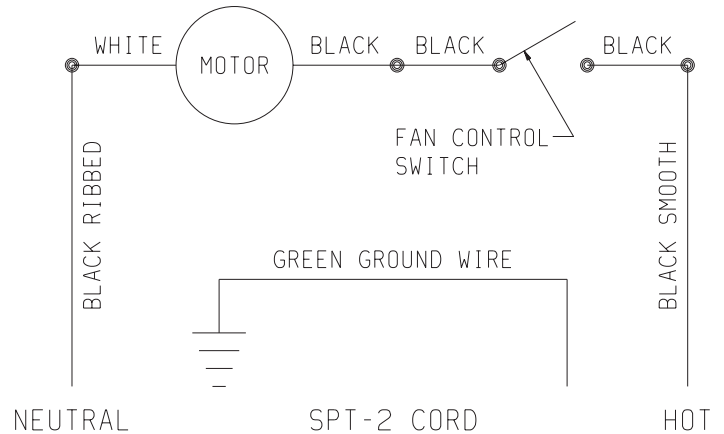



Empire Comfort Systems

Empire Comfort Systems, Inc.
918 Freeburg Ave. Belleville, IL 62220
PH: 618-233-7420 or 800-851-3153
FAX: 618-233-7097 or 800-443-8648
info@empirecomfort.com

www.empirecomfort.com