

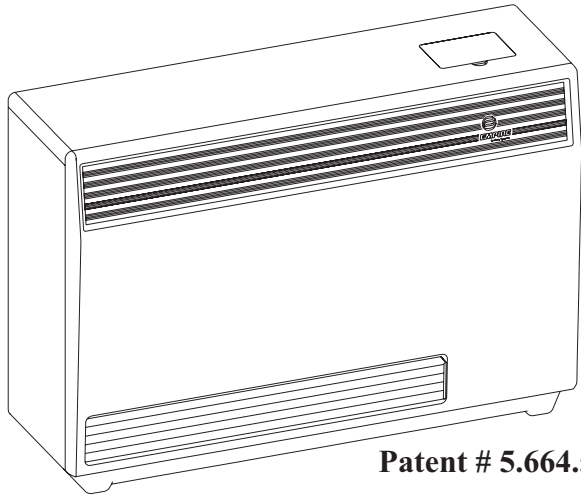

INSTALLATION INSTRUCTIONS AND OWNER'S MANUAL



Patent # 5.664.555

Installer: Leave this manual with the appliance.
Consumer: Retain this manual for future reference.

WARNING: If the information in these instructions are not followed exactly, a fire or explosion may result causing property damage, personal injury or loss of life.

- Do not store or use gasoline or other flammable vapors and liquids in the vicinity of this or any other appliance.
- **WHAT TO DO IF YOU SMELL GAS**
 - Do not try to light any appliance.
 - Do not touch any electrical switch; do not use any phone in your building.
 - Immediately call your gas supplier from a neighbor's phone. Follow the gas supplier's instructions.
 - If you cannot reach your gas supplier, call the fire department.
- Installation and service must be performed by a qualified installer, service agency or the gas supplier.

FAN TYPE DIRECT VENT WALL FURNACE

For Installation in
Manufactured (Mobile Home),
Modular or Residential Homes

**MODEL
DV-55E-5**



This appliance may be installed as an OEM installation in a manufactured home (USA only) or mobile home and must be installed in accordance with the manufacturer's instructions and the Manufactured Home Construction and Safety Standard, Title 24 CFR, Part 3280, in the United States, or the Mobile Home Standard, CAN/CSA Z240 MH Series, in Canada.

This appliance is only for use with the type(s) of gas indicated on the rating plate. A conversion kit is supplied with the appliance.

WARNING: If not installed, operated and maintained in accordance with the manufacturer's instructions, this product could expose you to substances in fuel or from fuel combustion which can cause death or serious illness.

TABLE OF CONTENTS

SECTION	PAGE
Important Safety Information	3
Safety Information for Users of LP Gas	4
Requirements for Massachusetts.....	5
Introduction.....	6
Specifications	6
Gas Supply	7
Gas Conversion Instructions	8
Clearances	9
Furnace Installation.....	9-11
Lighting Instructions	12
Wiring	13
Maintenance	14
Operation and Troubleshooting.....	15-16
How to Order Repair Parts.....	17
Parts List	17
Parts View	18
Service Notes	19

IMPORTANT SAFETY INFORMATION

**THIS IS A HEATING APPLIANCE
DO NOT OPERATE THIS APPLIANCE WITHOUT FRONT PANEL INSTALLED.**

- Due to high temperatures the appliance should be located out of traffic and away from furniture and draperies.
- Children and adults should be alerted to the hazards of high surface temperatures and should stay away to avoid burns or clothing ignition.
- Young children should be carefully supervised when they are in the same room as the appliance.
- Clothing or other flammable material should not be placed on or near the appliance.
- Any safety screen or guard removed for servicing an appliance must be replaced prior to operating the appliance.
- Keep burner and control compartment clean.
- Vent cap hot while furnace is in operation.
- For manufactured home (USA only) or mobile home or residential installation convertible for use with natural gas and liquefied petroleum gases when provision is made for the simple conversion from one gas to the other.
- Installation and repair should be done by a **QUALIFIED SERVICE PERSON**. The appliance should be inspected before use and at least annually by a qualified service person. More frequent cleaning may be required due to excessive lint from carpeting, bedding materials, etc. It is imperative that control compartments, burners and circulating air passageways of the appliance be kept clean.
- **DO NOT** put anything around the furnace that will obstruct the flow of combustion and ventilation air.
- **DO** keep the appliance area clear and free from combustible material, gasoline and other flammable vapors and liquids.
- **DO** examine venting system periodically and replace damaged parts.
- **DO** make a periodic visual check of burner. Clean and replace damaged parts.
- **DO NOT** use this heater if any part has been under water. Immediately call a qualified service technician to inspect the heater and to replace any part of the control system and any gas control which has been under water.

SAFETY INFORMATION FOR USERS OF LP-GAS

Propane (LP-Gas) is a flammable gas which can cause fires and explosions. In its natural state, propane is odorless and colorless. You may not know all the following safety precautions which can protect both you and your family from an accident. Read them carefully now, then review them point by point with the members

of your household. Someday when there may not be a minute to lose, everyone's safety will depend on knowing exactly what to do. If, after reading the following information, you feel you still need more information, please contact your gas supplier.

LP-GAS WARNING ODOR

If a gas leak happens, you should be able to smell the gas because of the odorant put in the LP-Gas.

That's your signal to go into immediate action!

- Do not operate electric switches, light matches, use your phone. Do not do anything that could ignite the gas.
- Get everyone out of the building, vehicle, trailer, or area. Do that IMMEDIATELY.
- Close all gas tank or cylinder supply valves.
- LP-Gas is heavier than air and may settle in low areas such as basements. When you have reason to suspect a gas leak, keep out of basements and other low areas. Stay out until firefighters declare them to be safe.
- Use your neighbor's phone and call a trained LP-Gas service person and the fire department. Even though you may not continue to smell gas, do not turn on the gas again. Do not re-enter the building, vehicle, trailer, or area.
- **Finally**, let the service man and firefighters check for escaped gas. Have them air out the area before you return. Properly trained LP-Gas service people should repair the leak, then check and relight the gas appliance for you.

NO ODOR DETECTED - ODOR FADE

Some people cannot smell well. Some people cannot smell the odor of the chemical put into the gas. You must find out if you can smell the odorant in propane. Smoking can decrease your ability to smell. Being around an odor for a time can affect your sensitivity or ability to detect that odor. Sometimes other odors in the area mask the gas odor. People may not smell the gas odor or their minds are on something else. Thinking about smelling a gas odor can make it easier to smell.

The odorant in LP-gas is colorless, and it can fade under some circumstances. For example, if there is an underground leak, the movement of the gas through soil can filter the odorant. Odorants

in LP-Gas also are subject to oxidation. This fading can occur if there is rust inside the storage tank or in iron gas pipes.

The odorant in escaped gas can adsorb or absorb onto or into walls, masonry and other materials and fabrics in a room. That will take some of the odorant out of the gas, reducing its odor intensity.

LP-Gas may stratify in a closed area, and the odor intensity could vary at different levels. Since it is heavier than air, there may be more odor at lower levels. Always be sensitive to the slightest gas odor. If you detect any odor, treat it as a serious leak. Immediately go into action as instructed earlier.

SOME POINTS TO REMEMBER

- Learn to recognize the odor of LP-gas. Your local LP-Gas Dealer can give you a "Scratch and Sniff" pamphlet. Use it to find out what the propane odor smells like. If you suspect that your LP-Gas has a weak or abnormal odor, call your LP-Gas Dealer.
- If you are not qualified, do not light pilot lights, perform service, or make adjustments to appliances on the LP-Gas system. If you are qualified, consciously think about the odor of LP-Gas prior to and while lighting pilot lights or performing service or making adjustments.
- Sometimes a basement or a closed-up house has a musty smell that can cover up the LP-Gas odor. Do not try to light pilot lights, perform service, or make adjustments in an area where the conditions are such that you may not detect the odor if there has been a leak of LP-Gas.
- Odor fade, due to oxidation by rust or adsorption on walls of new cylinders and tanks, is possible. Therefore, people should be particularly alert and careful when new tanks or cylinders are placed in service. Odor fade can occur in new tanks, or
- reinstalled old tanks, if they are filled and allowed to set too long before refilling. Cylinders and tanks which have been out of service for a time may develop internal rust which will cause odor fade. If such conditions are suspected to exist, a periodic sniff test of the gas is advisable. If you have any question about the gas odor, call your LP-gas dealer. A periodic sniff test of the LP-gas is a good safety measure under any condition.
- If, at any time, you do not smell the LP-Gas odorant and you think you should, assume you have a leak. Then take the same immediate action recommended above for the occasion when you do detect the odorized LP-Gas.
- If you experience a complete "gas out," (the container is under no vapor pressure), turn the tank valve off immediately. If the container valve is left on, the container may draw in some air through openings such as pilot light orifices. If this occurs, some new internal rusting could occur. If the valve is left open, then treat the container as a new tank. Always be sure your container is under vapor pressure by turning it off at the container before it goes completely empty or having it refilled before it is completely empty.

REQUIREMENTS FOR MASSACHUSETTS

For all side wall horizontally vented gas fueled equipment installed in every dwelling, building or structure used in whole or in part for residential purposes, including those owned or operated by the Commonwealth and where the side wall exhaust vent termination is less than seven (7) feet above finished grade in the area of the venting, including but not limited to decks and porches, the following requirements shall be satisfied:

1. **INSTALLATION OF CARBON MONOXIDE DETECTORS.** At the time of installation of the side wall horizontal vented gas fueled equipment, the installing plumber or gasfitter shall observe that a hard wired carbon monoxide detector with an alarm and battery back-up is installed on the floor level where the gas equipment is to be installed. In addition, the installing plumber or gasfitter shall observe that a battery operated or hard wired carbon monoxide detector with an alarm is installed on each additional level of the dwelling, building or structure served by the side wall horizontal vented gas fueled equipment. It shall be the responsibility of the property owner to secure the services of qualified licensed professionals for the installation of hard wired carbon monoxide detectors
 - a. In the event that the side wall horizontally vented gas fueled equipment is installed in a crawl space or an attic, the hard wired carbon monoxide detector with alarm and battery back-up may be installed on the next adjacent floor level.
 - b. In the event that the requirements of this subdivision can not be met at the time of completion of installation, the owner shall have a period of thirty (30) days to comply with the above requirements; provided, however, that during said thirty (30) day period, a battery operated carbon monoxide detector with an alarm shall be installed.
2. **APPROVED CARBON MONOXIDE DETECTORS.** Each carbon monoxide detector as required in accordance with the above provisions shall comply with NFPA 720 and be ANSI/UL 2034 listed and IAS certified.
3. **SIGNAGE.** A metal or plastic identification plate shall be permanently mounted to the exterior of the building at a minimum height of eight (8) feet above grade directly in line with the exhaust vent terminal for the horizontally vented gas fueled heating appliance or equipment. The sign shall read, in print size no less than one-half (1/2) inch in size, **“GAS VENT DIRECTLY BELOW. KEEP CLEAR OF ALL OBSTRUCTIONS”**.
4. **INSPECTION.** The state or local gas inspector of the side wall horizontally vented gas fueled equipment shall not approve the installation unless, upon inspection, the inspector observes carbon monoxide detectors and signage installed in accordance with the provisions of 248 CMR 5.08(2)(a) 1 through 4.
 - (b) **EXEMPTIONS:** The following equipment is exempt from 248 CMR 5.08(2)(a)1 through 4:
 1. The equipment listed in Chapter 10 entitled “Equipment Not Required To Be Vented” in the most current edition of NFPA 54 as adopted by the Board; and
 2. Product Approved side wall horizontally vented gas fueled equipment installed in a room or structure separate from the dwelling, building or structure used in whole or in part for residential purposes.
 - (c) **MANUFACTURER REQUIREMENTS - GAS EQUIPMENT VENTING SYSTEM PROVIDED.** When the manufacturer of Product Approved side wall horizontally vented gas equipment provides a venting system design or venting system components with the equipment, the instructions provided by the manufacturer for installation of the equipment and the venting system shall include:
 1. Detailed instructions for the installation of the venting system design or the venting system components; and
 2. A complete parts list for the venting system design or venting system.
 - (e) A copy of all installation instructions for all Product Approved side wall horizontally vented gas fueled equipment, all venting instructions, all parts lists for venting instructions, and/or all venting design instructions shall remain with the appliance or equipment at the completion of the installation.

INTRODUCTION

Introduction

Always consult your local Building Department regarding regulations, codes or ordinances which apply to the installation of a direct vent wall furnace.

Instructions to Installer

1. Installer must leave instruction manual with owner after installation.
2. Installer must have owner fill out and mail warranty card supplied with furnace.
3. Installer should show owner how to start and operate furnace and thermostat.
4. Installer must locate unit near a grounded wall receptacle for 115VAC power and must provide gas supply and vent the unit properly for safe operation.

Warning:

Any change to this furnace or its control can be dangerous. This is a heating appliance and any panel, door or guard removed for servicing an appliance must be replaced prior to operating the appliance.

General Information

This series is design certified in accordance with American National Standard / CSA Standard Z21.86 and CSA 2.32 by the Canadian Standards Association as a Fan Type Direct Vent Wall Furnace to be installed according to these instructions.

Any alteration of the original design, installed other than as shown in these instructions or use with a type of gas not shown on the rating plate is the responsibility of the person and company making the change.

Important

All correspondence should refer to complete Model Number, Serial Number and type of gas.

Notice: During initial firing of this unit, oil from the heat exchanger may bake out and smoke may occur. To prevent triggering of smoke alarms, ventilate the room in which the unit is installed.

Installation in Residential Garages

Gas utilization equipment in residential garages shall be installed so that all burners and burner ignition devices are located not less than 18" (457mm) above the floor.

Such equipment shall be located, or protected, so it is not subject to physical damage by a moving vehicle.

Qualified Installing Agency

Installation and replacement of gas piping, gas utilization equipment or accessories and repair and servicing of equipment shall be performed only by a qualified agency. The term "qualified agency" means any individual, firm, corporation or company which either in person or through a representative is engaged in and is responsible for (a) the installation or replacement of gas piping or (b) the connection, installation, repair or servicing of equipment, who is experienced in such work, familiar with all precautions required and has complied with all the requirements of the authority having jurisdiction.

State of Massachusetts: The installation must be made by a licensed plumber or gas fitter in the Commonwealth of Massachusetts.

The installation must conform with local codes, or in the absence of local codes, the National Fuel Gas Code, ANSI Z223.1/NFPA 54 or Natural Gas and Propane Installation Code, CSA B149.1.

*Available from the American National Standards Institute, Inc., 11 West 42nd St., New York, NY 10036.

A manufactured home (USA only) or mobile home OEM installation must conform with the Manufactured Home Construction and Safety Standard, Title 24 CFR, Part 3280, or, when such a standard is not applicable, the Standard for Manufactured Home Installations, ANSI Z225.1, or Standard for Gas Equipped Recreational Vehicles and Mobile Housing, CSA Z240.4.

High Altitudes

For altitudes/elevations above 2,000 feet (610m), input ratings should be reduced at the rate of 4 percent for each 1,000 feet (305m) above sea level, this may be accomplished by reducing manifold pressure. The maximum allowable reduction in manifold pressure for Natural gas shall be from 3.5" w.c. (.872kPa) to 2.8" w.c. (.697kPa). The maximum allowable reduction in manifold pressure for Propane (LP) gas shall be from 10.0" w.c. (2.49kPa) to 8.0" w.c. (1.99kPa). For Canadian high altitude applications, this appliance is suitable for installation at elevations between 0 feet (0m) and 4,500 feet (1,372m) without change.

SPECIFICATIONS

Model	DV-55E
Input BTU/HR (KW/H)	55,000 (16.1)
Height	26" (660mm)
Width	37" (940mm)
Depths with Shroud	15 3/4" (400mm)
Gas Inlet (Pipe)	1/2" (13mm)
Electrical - Unit has a 5' (1.5m) 3 pronged cordset for connection to an approved 115 VAC 60HZ maximum AMPs - 5A wall receptacle.	

Accessories for DV-55E Furnaces

Extended Vent Terminal	DVT-2
For walls up to 32" (813mm)	
Floor Pad	DVP-1

GAS SUPPLY

Consult the current National Fuel Gas Code, ANSI Z223.1 CAN/CGA-B149 (.1 or .2) installation code.

Recommended Gas Pipe Diameter

Pipe Length	Schedule 40 Pipe Inside Diameter		Tubing, Type L Outside Diameter	
	Nat.	L.P.	Nat.	L.P.
0-10 feet 0-3 meters	1/2"	3/8"	1/2"	3/8"
10-40 feet 4-12 meters	1/2"	1/2"	5/8"	1/2"
40-100 feet 13-30 meters	1/2"	1/2"	3/4"	1/2"
100-150 feet 31-46 meters	3/4"	1/2"	7/8"	3/4"

Note: Never use plastic pipe. Check to confirm whether your local codes allow copper tubing or galvanized.

Note: Since some municipalities have additional local codes, it is always best to consult your local authority and installation code.

The use of the following gas connectors is recommended:

- ANS Z21.24 Appliance Connectors of Corrugated Metal Tubing and Fittings
- ANS Z21.45 Assembled Flexible Appliance Connectors of Other Than All-Metal Construction

The above connectors may be used if acceptable by the authority having jurisdiction. The state of Massachusetts requires that a flexible appliance connector cannot exceed three feet in length.

FLEXIBLE GAS LINE CONNECTION

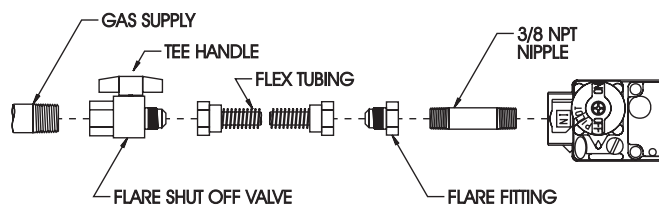

RIGID GAS LINE CONNECTION

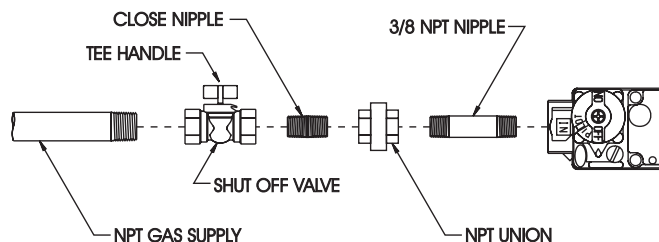

Figure 1

Installing a New Main Gas Cock

Each appliance should have its own manual gas cock.

A manual main gas cock should be located in the vicinity of the unit. Where none exists, or where its size or location is not ad-

equate, contact your local authorized installer for installation or relocation.

Compounds used on threaded joints of gas piping shall be resistant to the action of liquefied petroleum gases. The gas lines must be checked for leaks by the installer. This should be done with a soap solution watching for bubbles on all exposed connections, and if unexposed, a pressure test should be made.

Never use an exposed flame to check for leaks. Appliance must be disconnected from piping at inlet of control valve and pipe capped or plugged for pressure test. Never pressure test with appliance connected; control valve will sustain damage!

A gas valve and ground joint union should be installed in the gas line upstream of the gas control to aid in servicing. It is required by the National Fuel Gas Code that a drip line be installed near the gas inlet. This should consist of a vertical length of pipe tee connected into the gas line that is capped on the bottom in which condensation and foreign particles may collect.

Pressure Testing of the Gas Supply System

1. To check the inlet pressure to the gas valve, a 1/8" (3mm) N.P.T. plugged tapping, accessible for test gauge connection, must be placed immediately upstream of the gas supply connection to the appliance.
2. The appliance and its individual shutoff valve must be disconnected from the gas supply piping system during any pressure testing of that system at test pressures in excess of 1/2 psig (3.5 kPa).
3. The appliance must be isolated from the gas supply piping system by closing its individual manual shutoff valve during any pressure testing of the gas supply piping system at test pressures equal to or less than 1/2 psig (3.5 kPa).

Attention! If anyone of the procedures results in pressures in excess of 1/2psig (14" w.c) (3.5kPa) on the fireplace gas valve, it will result in a hazardous condition.

Checking Manifold Pressure

Both propane and Natural gas valves have a built-in pressure regulation in the gas valve. Natural gas models will have a valve outlet with the inlet pressure to the valve from a minimum of 5.0" w.c. (1.245kPa) for the purpose of input adjustment to a maximum of 10.5" w.c. (2.614kPa) Propane gas models will have a manifold pressure apporximately 10.0" w.s. (2.49kPa) at the valve outlet with the inlet pressure to the valve from a minimum of 11.0" w.c. (2.739kPa) for the purpose of input adjustment to a maxium of 13.0" w.c. (3.237kPa).

A 1/8" (3mm) N.P.T. plugged tapping, accessible for test gauge connection, is located on the outlet side of the gas control.

GAS CONVERSION INSTRUCTIONS

Warning: Conversion must be done by a qualified service technician. Main burner orifice(s) and new gas conversion label are provided in conversion kit attached to manifold pipe.

CONVERSION INSTRUCTIONS FROM (LP) PROPANE GAS TO NATURAL GAS

1. Make sure gas supply to furnace is off prior to conversion and disconnect electrical power to unit.
2. Open brass union located between the gas valve and burner box. Remove the 4 mounting screws securing manifold plate to the burner box. Remove the top 2 screws holding the burner box top in place and then remove the 1 screw holding the end of the manifold pipe in place. Grasp union and remove manifold pipe.
3. Remove (1) LP gas main burner orifice marked 55 for DV-20E, (2) LP gas main burner orifices marked 55 for DV-40E or (3) LP gas main burner orifices marked 1.20mm for DV-55E located in the manifold pipe and replace with (1) Natural gas main burner orifice marked 44 for DV-20E, (2) Natural gas main burner orifices marked 44 for DV-40E or (3) Natural gas main burner orifices marked 47 for DV-55E supplied in conversion kit.
4. Replace manifold pipe being sure to locate orifice(s) in the end of the burner. Secure the manifold and top burner box cover in place using the screws earlier removed. Reconnect the brass union.
5. Remove the vinyl cap and unscrew the gas control convertible regulator and reverse to Natural gas side and screw back into place. The red LP ring will be up just under the vinyl cap. Reattach vinyl cap. Refer to figure illustrating the gas valve.
6. Place LP gas main burner orifice(s) in conversion kit. Attach conversion kit to manifold pipe. Attach new label to unit nameplate indicating that the unit was converted to Natural gas.
7. Turn on gas supply to furnace and check all gas connections for leaks with soap solution, watching for bubbles on all gas connections.
8. Turn on electrical power to unit and turn on furnace to verify proper operation. It may take several tries for ignition to completely purge all the air from the gas line.

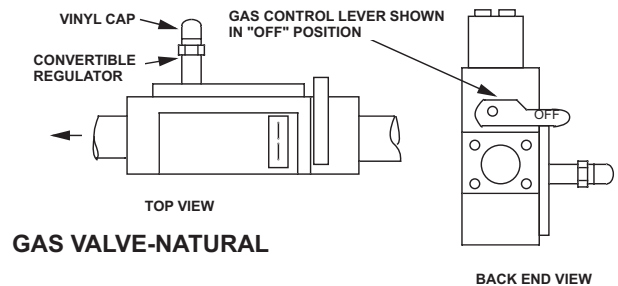

Warning: Conversion must be done by a qualified service technician. Main burner orifice(s) and new gas conversion label are provided in conversion kit attached to manifold pipe.

CONVERSION INSTRUCTIONS FROM NATURAL GAS TO (LP) PROPANE GAS

1. Make sure gas supply to furnace is off prior to conversion and disconnect electrical power to unit.
2. Open brass union located between the gas valve and burner box. Remove the 4 mounting screws securing manifold plate to the burner box. Remove the top 2 screws holding the burner box top in place and then remove the 1 screw holding the end of the manifold pipe in place. Grasp union and remove manifold pipe.
3. Remove (1) Natural gas main burner orifice marked 44 for DV-20E, (2) Natural gas main burner orifices marked 44 for DV-40E or (3) Natural gas main burner orifices marked 47 for DV-55E located in the manifold pipe and replace with (1) LP gas main burner orifice marked 55 for DV-20E, (2) LP gas main burner orifices marked 55 for DV-40E or (3) LP gas main burner orifices marked 1.20mm for DV-55E supplied in conversion kit.
4. Replace manifold pipe being sure to locate orifice(s) in the end of the burner. Secure the manifold and top burner box cover in place using the screws earlier removed. Reconnect the brass union.
5. Remove the vinyl cap and unscrew the gas control convertible regulator and reverse to LP gas side (red ring on regulator) and screw back into place. Reattach vinyl cap. Refer to figure illustrating the gas valve.
6. Place Natural gas main burner orifice(s) in conversion kit. Attach conversion kit to manifold pipe. Attach new label to unit nameplate indicating that the unit was converted to LP gas.
7. Turn on gas supply to furnace and check all gas connections for leaks with soap solution, watching for bubbles on all gas connections.
8. Turn on electrical power to unit and turn on furnace to verify proper operation. It may take several tries for ignition to completely purge all the air from the gas line.

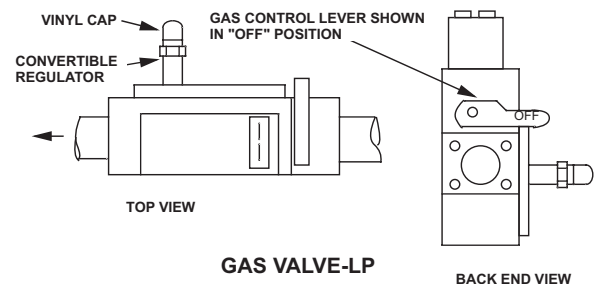

CLEARANCES

1. Pick a location on a wall with a clear space of 36" (91.4cm) high by 43" (109cm) wide in the room. In selecting a location for installation, it is necessary to provide adequate accessibility clearances for servicing and proper installation. Be sure to locate the unit close enough to a 115 VAC wall receptacle to properly power appliance.
2. Unit is supported by a wall bracket secured to the wall.
3. When facing the front of the furnace the minimum clearances from casing to combustible construction are 10" (254mm) on top, 3" (76mm) on each side, recommend 18" (457mm) on right side for servicing and 0" (0mm) from the floor and 0" (0mm) to rear wall.
4. The minimum distance from the center of the vent cap to the nearest outside corner or obstruction is 12" (305mm).
5. The minimum wall depth is 2" (51mm) and the maximum is 10" (254mm) [or 32" (813mm) using the extended vent terminal kit accessory]. The use of vent tubes not supplied by the manufacturer may result in unsatisfactory performance.

The vent terminal of a direct vent appliance, with an input of

50,000 BTU (14.6KW) per hour or more shall be located at least 12" (305mm) from any opening through which flue gases could enter a building.

The bottom of the exhaust vent terminal and the air intake shall be located at least 12" (305mm) above grade and must be vented outside.

WARNING: The nearest point of the vent cap should be a minimum horizontal distant of six (6) feet (1.83m) from any pressure regulator. In case of regulator malfunction, the six (6) feet (1.83m) distance will reduce the chance of gas entering the vent cap.

Installation on Rugs and Tile

If this appliance is to be installed directly on carpeting, tile, or other combustible material, other than wood flooring, the appliance shall be installed on a metal or wood panel extending the full width and depth of the appliance.

The base referred to above does not mean the fire-proof base as used on wood stoves. The protection is primarily for rugs that may be extremely thick and light-color tile that can discolor.

FURNACE INSTALLATION

Locating Wall Opening (Figures 2, 3 and 4)

This furnace must be installed on an outside wall. Locate wall studs so that wall vent opening will be located between wall studs. The wall studs can be used for attachment of wall mounting bracket. The wall opening required for venting is a 3 1/4" (83mm) diameter opening.

Refer to Figures 2 and 3 for positioning the furnace on wall and for locating gas line connection and vent opening. Furnace can sit on the floor and should be secured to the wall through the wall bracket secured to the rear shroud.

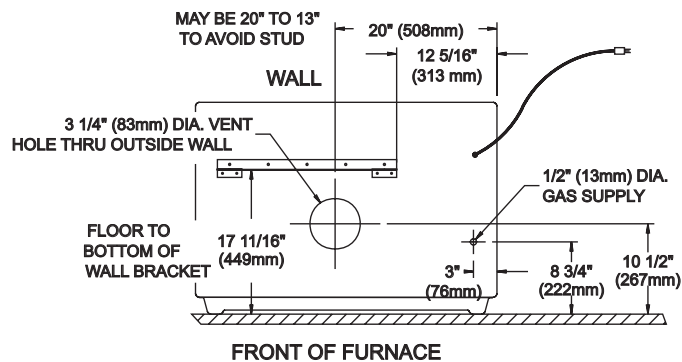

Figure 2

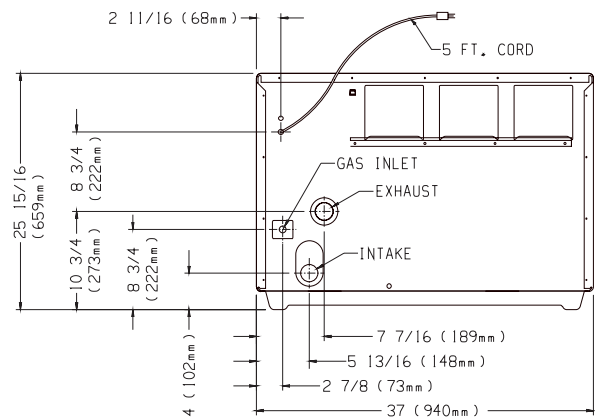

Figure 3

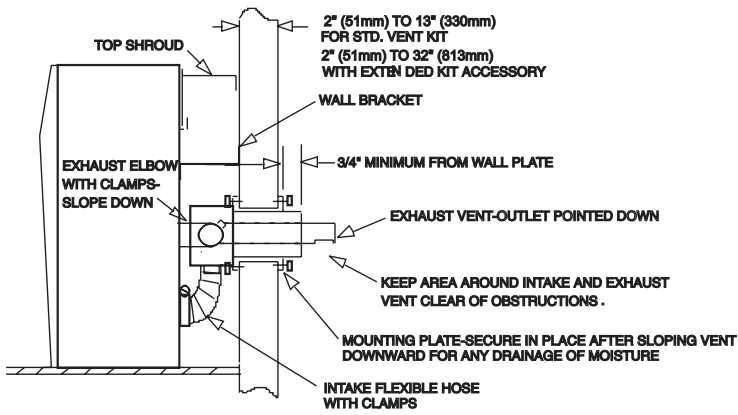

Figure 4

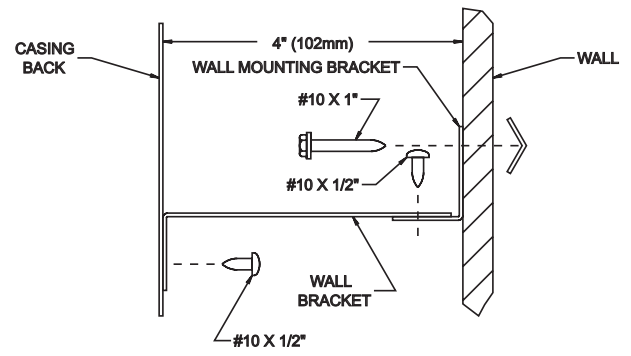

Figure 6

Installing Wall Bracket (Figures 5 and 6)

After finding a location for the furnace, gas supply and vent, the wall bracket must be positioned and installed. The bracket should be mounted to the wall studs, if possible, or anchored solidly to the wall. Use the (2) 10 x 1 1/2" (38mm) hex-head screws or (2) plastic anchors provided. Drill (2) 5/16" (8mm) diameter holes in wall if plastic anchors are used. Attach the two wall mounting brackets to the casing back by using (4) 10 x 1/2" (13mm) hex-head screws provided.

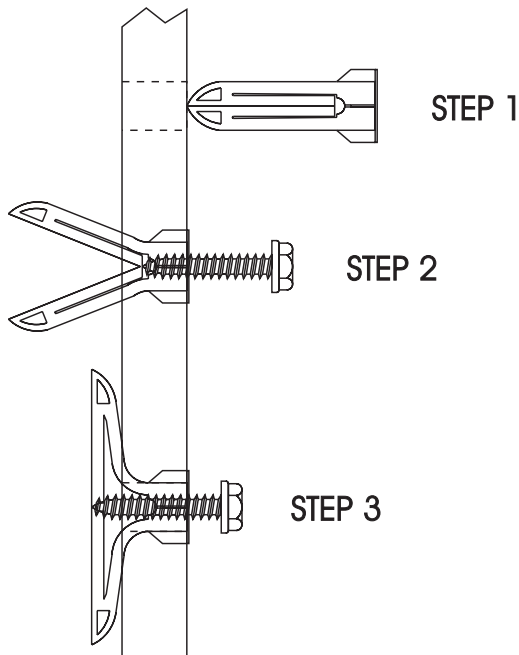

Figure 5

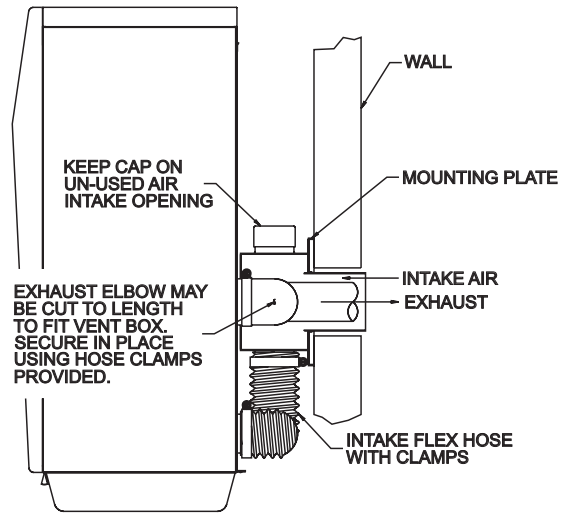

Figure 7

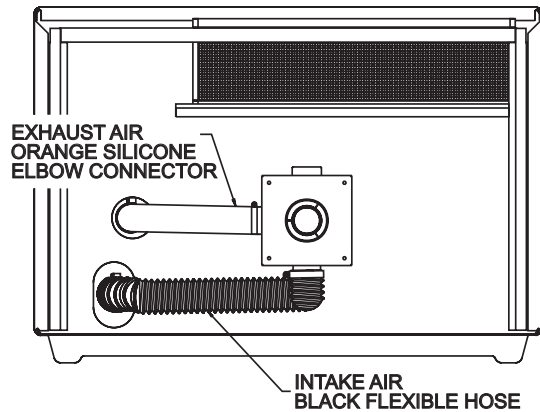

Figure 8

FURNACE INSTALLATION (continued)

Venting (Figures 7 and 8)

This unit is vented directly out the back using the concentric vent tube assembly provided. See Figure 2 for vent hole location. This hole location can be conveniently moved closer to unit exhaust outlet tube to avoid wall stud interference if necessary. The orange silicone exhaust elbow would need to be cut to length. Do not locate vent directly behind the exhaust outlet.

The vent provided will accommodate walls up to 10" thick and can be cut shorter for thinner walls if desired by using a hacksaw or cut-off saw. Be sure to leave the minimum 3/4" of tube length extending beyond the outside wall plate. Both the inner and outer tube will be cut to the same length as the inner exhaust tube has an extension piece which is added during final outside assembly.

Be sure to deburr the ends with a file after cutting. Installation is easy after cutting the wall opening secure the vent terminal box in place using the (4) 10 x 1" hex-head screws provided. Locate the box so that the middle exhaust tube is directed toward the furnace exhaust outlet opening. See Figure 8. Attach the black 2" flexible inlet air hose to the bottom 2" connector on the vent box using a hose clamp. Secure the other end to the lower inlet air box connector using the hose clamp. Do not kink hose. Attach the long straight end of the 2" orange silicone exhaust elbow to the middle vent terminal tube and rotate the elbow toward the furnace exhaust outlet. Secure the hose to the vent box using a hose clamp. Carefully push the furnace back closer to the wall and secure the exhaust elbow to the 2" exhaust tube exiting the unit. Secure the elbow in place using the last remaining hose clamp. The furnace can now be secured to the wall.

For wall depths thicker than 10" (254mm) order the extended vent terminal kit which will cover walls to 32" (813mm) thickness. The vent pipes must be cut to length to assemble for desired wall thickness. Do not extend venting beyond the 32" maximum length.

Installation of Shroud

To complete inside installation, secure furnace to the wall bracket by attaching the two wall mounting brackets to the wall bracket by using (2) 10 x 1/2" (13mm) hex-head screws provided (See Figures 4 and 6). To attach the right shroud and left shroud to the casing back, the 3/4" wide flange on the shroud must be positioned toward the casing side. When positioned correctly, the (6) louvers on the shroud will be facing up and the knock-out on the shroud will be facing down. Attach the right shroud and left shroud to the casing back with (3) 10 x 1/2" hex-head screws supplied in hardware package, for each shroud. Attach top shroud to right shroud and left shroud with (4) Phillips-head screws, supplied in hardware package. Insert air filter into top shroud.

Attention: If the right shroud and left shroud are installed incorrectly, with the 3/4" wide flanges facing inward, the top shroud will not be able to be installed onto the side shrouds. The top shroud will appear to be 2 inches, too narrow.

Vent Terminal (Figure 9)

Place the 6 3/8" x 6 3/8" (162mm x 162mm) black foam, wall plate gasket within the mounting plate. The 4 3/4" (121mm) diameter hole in the black foam gasket will allow for installation of the concentric vent tube assembly. Slide the outside mounting plate into place on the concentric vent tube assembly. The outside mounting plate should seal against the face of the building and be secured in place using (4) 10 x 1" hex-head screws. Be sure to caulk and seal around the pipe on the exterior using high temperature exterior grade, silicone caulk rated at 204°C/400°F. Wipe some silicone sealant on the 2" (51mm) exhaust pipe extension. The end cap can be pushed into place on the exhaust outlet tube.

Attention: The opening on the bottom of the end cap must be positioned toward the ground. The opening on the bottom cannot be pivoted to the right or left, it must be centered toward the ground.

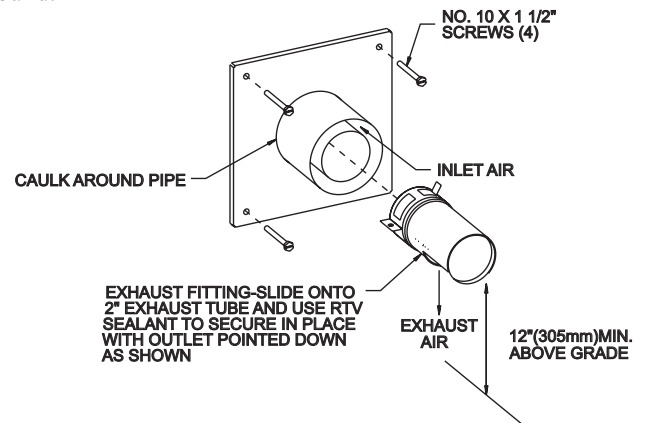

Figure 9

Reassembly and Resealing Vent-Air Intake System

When vent-air intake system is removed for servicing the furnace, the following steps will assure proper reassembly and resealing of the vent-air intake assembly. Be sure all hose connections are re-secured in place using the hose clamps removed. Reattach all screws securing mounting flanges and inspect all connections for a tight fit. Use high temperature silicone caulk rated at 204°C/400°F to reseal the inlet air vent pipe to the mounting plate.



LIGHTING INSTRUCTIONS

FOR YOUR SAFETY READ BEFORE OPERATING

WARNING: If you do not follow these instructions exactly, a fire or explosion may result causing property damage, personal injury or loss of life.

- A. This appliance does not have a pilot. It is equipped with an ignition device which automatically lights the burner. Do not try to light the burner by hand.
- B. BEFORE OPERATING smell all around the appliance area for gas. Be sure to smell next to the floor because some gas is heavier than air and will settle on the floor.
- WHAT TO DO IF YOU SMELL GAS
- Do not try to light any appliance.
 - Do not touch any electrical switch; do not use any phone in your building.
 - Immediately call your gas supplier from a neighbor's phone. Follow the gas supplier's instructions.
 - If you cannot reach your gas supplier, call the fire department.
- C. Use only your hand to push in or turn the gas control knob. Never use tools. If the knob will not push in or turn by hand, don't try to repair it; call a qualified service technician. Force or attempted repair may result in a fire or explosion.
- D. Do not use this appliance if any part has been under water. Immediately call a qualified service technician to inspect the appliance and to replace any part of the control system and any gas control which has been under water.

OPERATING INSTRUCTIONS

1. STOP! Read the safety information above.
2. Set the thermostat to lowest setting.
3. Turn off all electric power to the appliance.
4. This appliance is equipped with an ignition device which automatically lights the burner. Do not try to light the burner by hand.
5. Remove control access panel (front panel).
6. Turn gas control knob clockwise  to "OFF."
7. Wait ten (10) minutes to clear out any gas. Then smell for gas, including near the floor. If you smell gas, STOP! Follow "B" in the safety information above. If you don't smell gas, go to the next step.
8. Turn gas control knob counterclockwise  to "ON".
9. Replace control access panel (front panel).
10. Turn on all electric power to the appliance.
11. Set thermostat to desired setting.
12. If the appliance will not operate, follow the instructions "TO TURN OFF GAS TO APPLIANCE" and call your service technician or gas supplier.

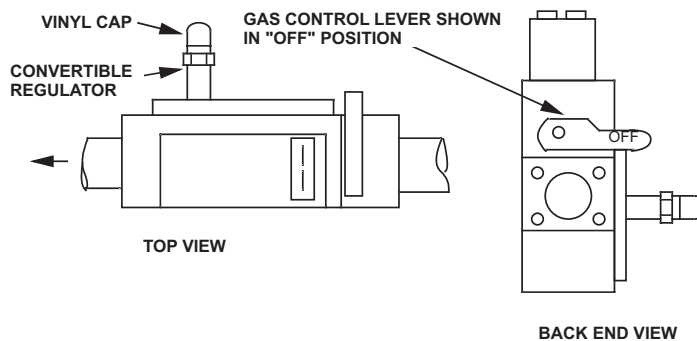

TO TURN OFF GAS TO APPLIANCE

1. Set the thermostat to lowest setting.
2. Turn off all electric power to the appliance if service is to be performed.
3. Remove control access panel (front panel).
4. Turn gas control knob clockwise  to "OFF." Do not force.
5. Replace control access panel (front panel).

WIRING

WIRING DIAGRAM

WARNING: DISCONNECT THE ELECTRIC POWER BEFORE SERVICING

GV = GAS VALVE
 LS = LIMIT SWITCH
 FS = FLAME SENSOR
 XFMR = TRANSFORMER
 PS = PRESSURE SWITCH
 IGN = HOT SURFACE IGNITOR
 ROS = ROLLOUT LIMIT SWITCH

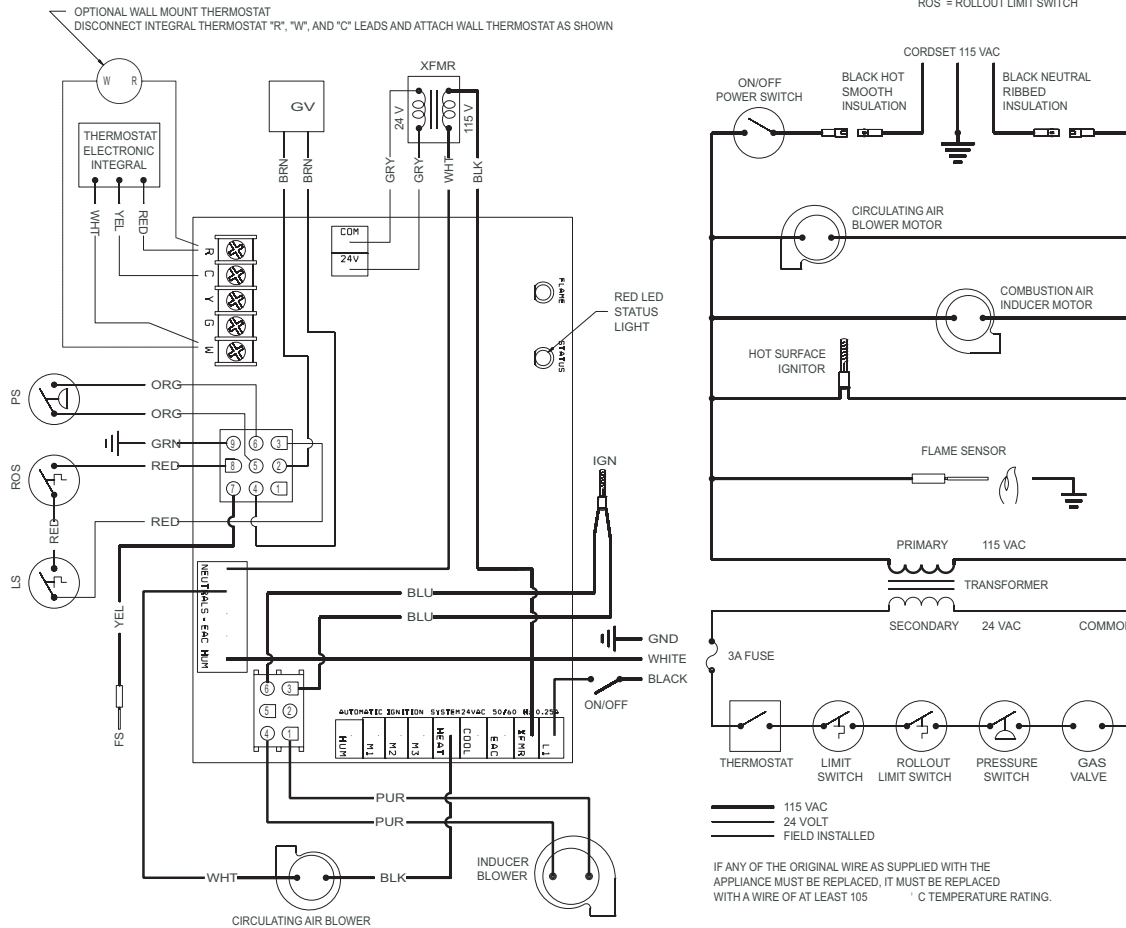

The appliance, when installed, must be electrically grounded in accordance with local codes or, in the absence of local codes, with the National Electrical Code, ANSI/NFPA 70 or Canadian Electrical Code, CSA C22.1, if an external electrical source is utilized. **This appliance is equipped with a three-prong [grounding] plug for your protection against shock hazard and should be plugged directly into a properly grounded three-prong receptacle. Do not cut or remove the grounding prong from this plug.** For an ungrounded receptacle, an adapter, which has two prongs and a wire for grounding, can be purchased, plugged into the ungrounded receptacle and its wire connected to the receptacle mounting screw. With this wire completing the ground, the appliance cord plug can be plugged into the adapter and be electrically grounded.

CAUTION: Label all wires prior to disconnection when servicing controls. Wiring errors can cause improper and dangerous operation. Verify proper operation after servicing.

Note: For testing flame sensor circuit use a micro-amp meter in series with sensor. Minimum current should be 1 micro-amp during operation. Be careful as flame sensor is in the 115VAC circuit. If current is below 1 micro-amp, remove sensor, clean with light sandpaper and retest.

Note: This heater is equipped with a remote bulb electronic thermistor control located down low at the back of the furnace. Sometimes due to field locations different air currents may effect the control sensing of the

thermistor. This sensing bulb can be re-located if necessary to provided for better room air sensing and control.

Replacement of Thermistor with 24 Volt Wall Thermostat

1. If furnace is installed, turn off gas supply and electric supply.
2. Remove casing front.
3. Remove black hose from front nipple on pressure switch.
4. Remove junction box cover (4 screws).
5. Please refer to wiring diagram for removal of the following wires.
6. **Internal Electronic Thermostat/Temperature Control Board Attention! No 24 volt wall thermostat wires are to be attached to the internal electronic thermostat.**
7. Control Board
 - A. Remove white wire form screw marked W.
 - B. Remove yellow wire from screw marked C.
 - C. Remove red wire from screw marked R.
8. Route (2) wires from any 24 volt wall thermostat through the casing back of furnace to the screws marked W and R on the control board.
9. Replace junction box cover (4 screws).
10. Replace black hose onto front nipple on pressure switch.
11. Replacement of thermistor with 24 volt wall thermostat is completed.

MAINTENANCE

Proper Main Burner Flame

The proper main burner flame will be a blue primary (inner) flame with a larger, lighter blue secondary (outer) blue flame.

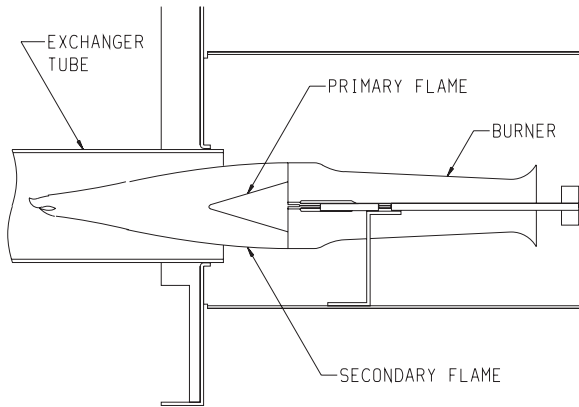

Figure 10

Cleaning Main Burner(s)

Remove main burner(s) and apply air pressure inside the throat and ports of the main burner(s).

Removing Main Burner(s)

1. Remove front grill assembly.
2. Remove burner compartment access panel (2 screws).
3. Remove main burner(s) from burner compartment (2 screws per main burner).

Removing Gas Valve

1. Remove front grill assembly.
2. Disconnect manifold union assembly at gas valve.
3. Remove (2) two 24 volt wires from gas valve. Label wires prior to disconnection from gas valve.
4. Remove gas valve from gas valve bracket.

Removing Main Burner Orifice(s)

1. Remove front grill assembly.
2. Remove burner compartment access panel (2 screws).
3. Disconnect manifold union assembly.
4. Disconnect manifold union assembly brackets (5 screws).

Removing Ignitor and Flame Sensor

1. Remove front grill assembly.
2. Remove ignitor from burner compartment (2 screws).
3. Remove flame sensor from burner compartment (1 screw).

Cleaning Combustion (Exchanger) Assembly

A QUALIFIED SERVICE PERSON should remove the combustion (exchanger) assembly. Apply air pressure to the inside of the combustion (exchanger) assembly in order to clear all passageways.

Oiling

The blower motor has an oil hole located on each end of the motor. Use #20 motor oil only. It is best to oil the motor several times during the heating season using 2 or 3 drops each time.

OPERATION AND TROUBLESHOOTING

Your new furnace should provide many years of trouble free performance, however, a yearly inspection of the burners , flue passageways and the outlet vent assembly should be done. Be sure all passageways are open and clear of any obstruction, or soot build up. Be sure to shut off all power to the unit while performing this inspection.

Periodically remove the circulating air filter and clean with water to remove all dirt. Shake dry and reinstall in unit.

System Operation

1. This furnace has an electronic thermostat and control board to monitor the room temperature and then control the furnace operation to provide the best comfort and performance from a heating appliance. To operate unit turn ON/OFF switch to ON and then turn temperature control knob clockwise slowly till furnace turns on. For typical room comfort, the control knob should be pointed toward medium.
2. The furnace control board follows sequence of operation which allows for self diagnosis in the event there is a problem. The control then blinks a status light, a set number of blinks based on what problem has been encountered. When the furnace is on and there is a no fault condition, the red LED is on. On a typical call for heat by the integral thermostat 24 VAC is applied to the W terminal on the board. The inducer blower circuit is energized and the inducer blower comes on for 15 seconds pre-purging out any gas and closing the pressure switch.

The hot surface ignitor is energized and after a 17 second warm-up, the gas valve circuit is energized, opening the gas valve and igniting the burners. After burning for about 30 seconds, the circulating air blower comes on, delivering warm air to the room. If ignition does not occur, the ignition sequence is repeated again up to 2 more times. (3 trials for ignition-total)

3. After the furnace operates and satisfies the thermostat, the gas valve closes and the circulating air blower continues to run for about 2 minutes and then shuts off. The inducer blower runs for 5 seconds and shuts off.

If for any reason ignition and operation does not occur, the control board will blink the red fault status LED, a sequence code, indicating what to look for as a troubleshooting guide. If the red LED is ON but not blinking check the electronic temperature control to verify its operation. This can be easily done by disconnecting the 3 electronic temperature control leads from the main furnace board and using a pig tail jumper to connect R & W together on the board. If the furnace comes on and runs normally the temperature control board is malfunctioning. If the heater still does not come on, then the main furnace board is malfunctioning. Look for any fault codes below and verify the 3 amp fuse is not blown.

**FURNACE CONTROL BOARD
DIAGNOSTICS
FAULT SEQUENCE CODE — TROUBLE SHOOTING GUIDE**

# of Blinks	Fault Condition	Fault Correction
Steady On	Control OK	
1 Flash	Temperature limit switch is open	-Check Circulating Air Blower Inlet or Grill Outlet for Blockage, Inducer Blower/Circulating Air Blower Run to Cool Heat Exchanger and Limit -Check for Flame Roll Out Condition Causing Roll Out Limit Switch on Burner Box to Open -Clean Circulating Air Filter
2 Flashes	Pressure switch is open with inducer on	-Check Heat Exchanger and Flue System, Outlet and Inlet for Restriction -Check Inducer Blower/Wheel for Operation/Airflow -Check Pressure Switch
3 Flashes	Pressure switch is closed with inducer off	-Check Pressure Switch and Replace
4 Flashes	Lockout due to failed ignition	-Check for Broken Ignitor -Check for Bent Ignitor Bracket - Ignitor too far from Burner -Check for Flame Sensor Malfunction/or False Ground -Check Gas Valve -Reset Thermostat
5 flashes	L1/Neutral reversed or voltage not present on L1	-Shut Off Power to Unit and Dis-Connect Cordset Plug from Wall Receptacle. Open Junction Box and Un-Reverse Polarity of Incoming Power Leads
Rapid Flash	Flame sense or internal control fault	-Check Ignitor Operation -Check Flame Sensor for Malfunction or False Grounding -Check Gas Valve -Reset Thermostat

Note: If the hot surface ignitor is to be replaced, be sure to disconnect all power to the unit. Be very careful in handling the new ignitor as they are fragile and can be broken easily if hit or dropped.

HOW TO ORDER REPAIR PARTS

Parts can be ordered only through your service person or dealer. For best results, the service person or dealer should order parts through the distributor. Parts can be shipped directly to the service person/dealer.

All parts listed in the Parts List have a Part Number. When ordering parts, first obtain the Model Number from the name plate on your equipment. Then determine the Part Number (not the Index Number) and the Description of each part from the following appropriate illustration and list. Be sure to give all this information.

Furnace Model Number _____ Part Description _____

Furnace Serial Number _____ Part Number _____

Type of Gas (Propane or Natural) _____

Do not order bolts, screws, washers or nuts. They are standard hardware items and can be purchased at any local hardware store.

Shipments contingent upon strikes, fires and all causes beyond our control.

Empire Comfort Systems, Inc. Nine Eighteen Freeburg Ave. Belleville, IL 62222-0529

PARTS LIST

PLEASE NOTE: When ordering parts, it is very important that part number and description of part coincide.

INDEX NO.	PART NUMBER	DESCRIPTION	INDEX NO.	PART NUMBER	DESCRIPTION
1	DV-1378	SHROUD TOP	33	15785	EXCHANGER ASSEMBLY
2	DV-1376	SHROUD SIDE RIGHT	34	19565	IGNITOR KIT
3	R-2521	AIR FILTER	37	R-2543	FLAME SENSOR
4	DV-1375	FILTER RETAINER	38	R-2541	BURNER - 3 REQ
5	DV-1379	WALL MOUNTING BRACKET	39	R-2575	FLAME ROLLOUT SWITCH
6	DV-1048	WALL BRACKET - 2 REQ	40	DV-1038	BURNER COMPARTMENT ACCESS PANEL
7	R-2586	CONTROL DOOR PIN - 2 REQ	41	DV-1143	BURNER COMPARTMENT
8	19676	CONTROL DOOR ASSEMBLY	42	R-3237	GAS VALVE - NAT
9	DV-1373	CASING TOP	42	R-3238	GAS VALVE - LP
10	R-2661	BLOWER HOUSING - 2 REQUIRED	43	DV-1366	VALVE BRACKET
11	R-2663	BLOWER WHEEL - 2 REQ	44	DV-1147	MANIFOLD ASSEMBLY
12	R-2662	BLOWER MOTOR	45	P-88-1.20MM	ORIFICE (LPG GAS) - 3 REQ
13	R-2598	MOTOR BASE WASHER - 4 REQ	45	P-88-47	ORIFICE (NAT GAS) - 3 REQ
14	R-1279	LIMIT SWITCH	46	M-148	MANIFOLD GASKET
15	DV-1367	INNER TOP	47	DV-781	OBSERVATION HOLE COVER ASSEMBLY
16	R-2546	CONTROL KNOB	48	M-155	OBSERVATION HOLE COVER GASKET
17	R-2522	ON/OFF SWITCH	49	15792	FRONT SHIELD ASSEMBLY
18	19561	JUNCTION BOX	50	DV-1024	BOTTOM SHIELD
19	DV-1370	JUNCTION BOX COVER	51	DV-1364	FRONT GRILL ASSEMBLY
20	R-1995	TRANSFORMER	52	DV-1380	CASING FRONT ASSEMBLY
21	R-6988	PRESSURE SWITCH	53	R-2539	HOSE CLAMP - 4 REQ
22	R-8140	CONTROL BOARD	54	R-3113	INLET HOSE
23	R-2577A	TEMPERATURE CONTROL BOARD	55	R-3111	OUTLET ELBOW
24	DV-1365	CASING WELDED ASSEMBLY	56	DV-1192	VENT PAN ASSEMBLY
25	R-1468	STRAIN RELIEF BUSHING	57	R-3114	INLET CAP
26	R-2099	CORD SET	58	R-3115	WALL PLATE GASKET - INSIDE
27	DV-1371	INNER END	59	R-2587	WALL PLATE GASKET - OUTSIDE
28	DV-1372	CASING SIDE - 2 REQUIRED	60	DV-1195	WALL PLATE - OUTSIDE
29	DV-1163	COLLECTOR BOX	61	DV-1193	TUBE SPACER
30	R-2519	INDUCER WHEEL	62	DV-1194	END CAP ASSEMBLY
31	DV-1169	INDUCER BLOWER HOUSING ASSEMBLY	63	DV-1377	SHROUD SIDE LEFT
32	R-2523	INDUCER MOTOR	NS	R-8142	WIRE ASSEMBLY - CONTROL BOARD

PARTS VIEW

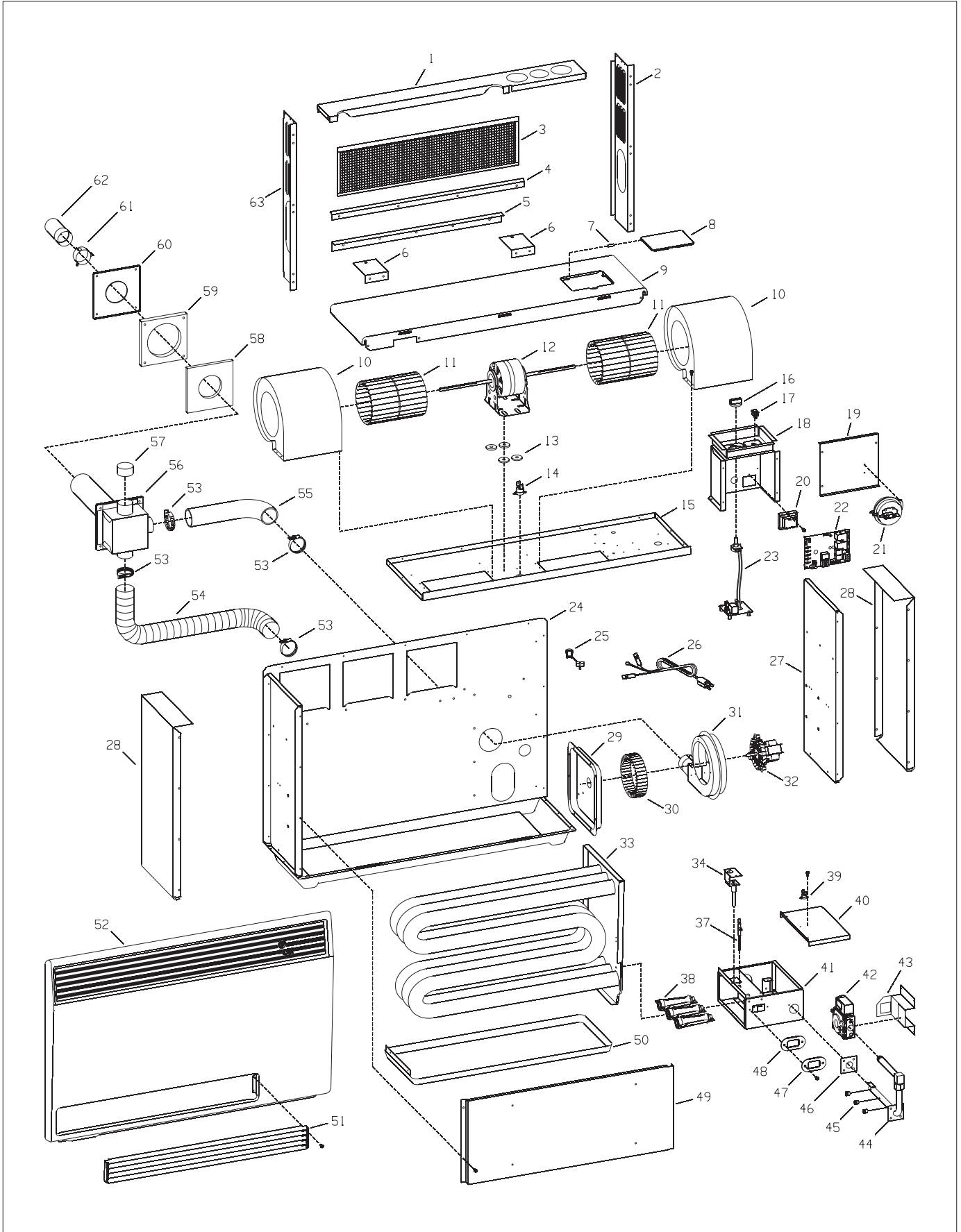



Empire Comfort Systems

Empire Comfort Systems, Inc.
918 Freeburg Ave. Belleville, IL 62220
PH: 618-233-7420 or 800-851-3153
FAX: 618-233-7097 or 800-443-8648
info@empirecomfort.com

www.empirecomfort.com