

# Easy2Build™

Smart Tech solutions



## 8' x 8' Easy-Grow Greenhouse

### Assembly Instructions

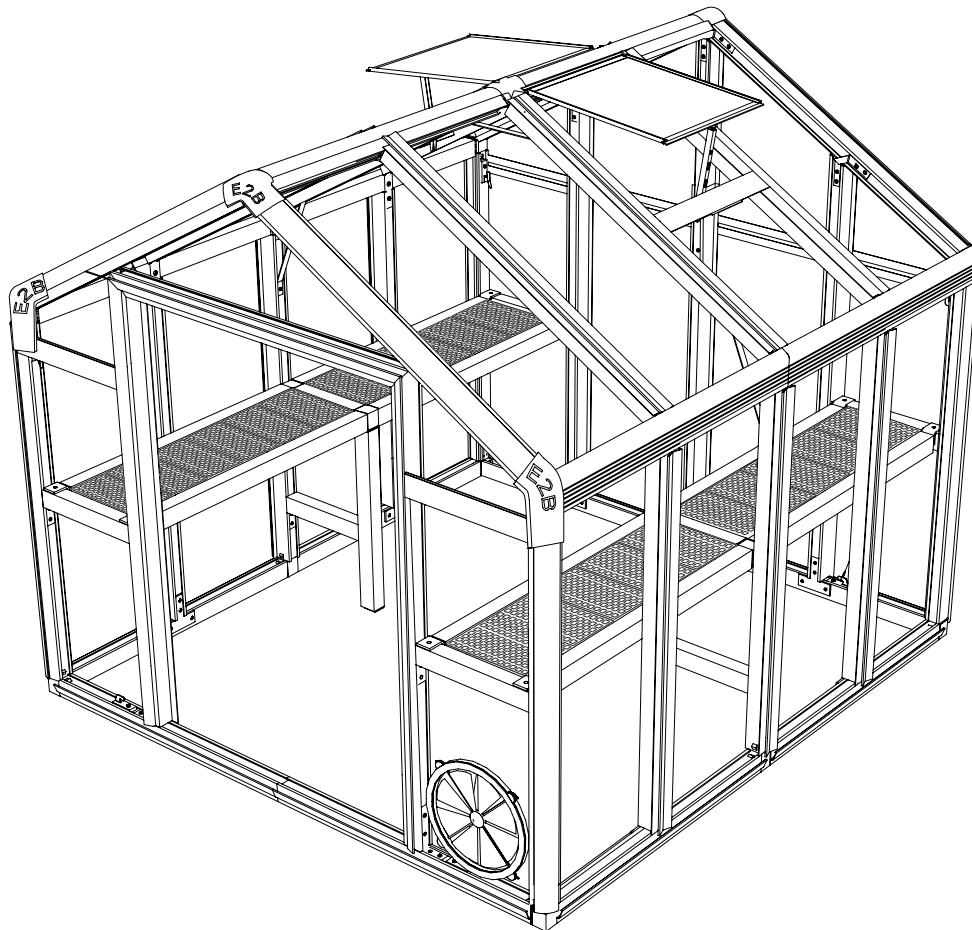

Systems Trading Corporation  
450 7th Avenue Suite 2809, New York, NY 10123  
Customer Service: (877) 407-9100 ext 1 Email: [customerservice@stcaustin.com](mailto:customerservice@stcaustin.com)



# Introduction

Thank you for purchasing your Easy2Build™ 8x8 Easy-Grow Greenhouse. This model features two roof vents and a circular air vent to ensure proper ventilation. We have also included an automatic vent opener to help you maintain optimal temperature effortlessly. When properly assembled and maintained, this greenhouse will provide years of enjoyment.

These instructions include helpful hints and important information needed to safely assemble and properly maintain the greenhouse. Please carefully read these instructions completely before you begin.

This greenhouse has been designed with patented technology to be easily assembled. All but one step can be completed by one person. You will require assistance from another person to attach the roof. Although the greenhouse can be assembled in six to eight hours, we recommend that you take your time and make it a weekend project.

## Before Starting Assembly:

**CAREFULLY READ ALL INSTRUCTIONS BEFORE YOU BEGIN AND FOLLOW THE STEPS IN THE ORDER THEY ARE PRESENTED.**

### 1. Make sure you have all the necessary parts:

Compare the contents of the two cartons to the List of Parts. If any parts are missing or damaged or you have any questions, please contact Customer Service by phone at (877) 407-9100 ext. 1 or by email at [customerservice@stcaustin.com](mailto:customerservice@stcaustin.com) before beginning assembly.

### 2. Lay the parts out in separate staging areas:

The List of Parts has the corresponding step number referenced to each part. We recommend that while you go through the list, make staging areas for each step and place the parts necessary for each step in these areas. This will save you time and effort during assembly.

### 3. Select a Location:

When selecting a site for your greenhouse, a flat level area is essential and if possible, with proper water drainage and easy access to power and water necessary for greenhouse gardening.

Choose a sunny, level position away from overhanging trees and power lines and protected from the wind as much as possible. The location should be away from structures that could cause snow to drift on or around the greenhouse.

Locate underground pipes or cables before preparing the site or anchoring the greenhouse.

Note: You may assemble the greenhouse on a hard level surface and move it to its final position when finished. Make sure there are no obstacles between the assembly area and the final position.

### 4. Prepare a Foundation:

After choosing a location, proper preparation of the site is essential. The site must be level. If the site is not level, create a base slightly larger than the outside dimensions of the greenhouse using a perimeter of two by fours filled with either soil, sod or gravel. Make sure the base is square by measuring the diagonals from both sides and making sure they are equal. The greenhouse is secured from the inside with pegs into holes cast with concrete. See step 16 for details.

If you decide to have a concrete base, it is best to contact a reliable contractor to ensure it is flat and level. Make sure you have checked with your local authorities regarding any required building permits.

### 5. Make sure you have the proper tools:

- Tape Measure
- Work Gloves
- Safety Goggles
- Phillips Screwdriver
- Spirit Level
- Small Step Ladder
- Wooden Mallet
- Liquid Soap or WD40 Lubricant
- Scissors
- Hex Key (included)

NOTE: A cordless drill with Phillips head bit is highly recommended but not essential.

# Safety Advice

The greenhouse must be positioned and fixed on a flat level surface.

Dispose of all plastic bags safely. Keep them out of the reach of small children.

Keep children and pets away from the assembly area until the work is completed.

Always wear shoes, gloves and safety goggles when working.

In manufacturing all sharp edges and burs have been removed but caution should still be taken when handling metal parts.

Do not lean against or push the greenhouse during assembly.

Take special care not to touch overhead power lines with the aluminium profiles.

Do not attempt to assemble the greenhouse in windy or wet conditions.

Do not position your greenhouse in an area exposed to excessive wind.

If using power tools or a step ladder always follow the manufacturers safety instructions.

Hot items such as recently used grills, blowtorches etc. must not be stored in the greenhouse.

Store the polycarbonate panels in a cool dark place like a garage until you are ready to use them.

Make sure the greenhouse complies with local building codes.

# Table of Contents

Introduction .....	1
Safety Advice .....	2
General Order of Assembly .....	2
List of Parts .....	3
Assemble Back .....	6
Assemble Doors .....	15
Assemble Front .....	19
Assemble Sides .....	27
Prepare Shelves .....	32
Connect Sides to Back .....	33
Connect Sides to Front .....	35
Assemble and Connect Gables .....	38
Brace Sides .....	42
Assemble and Install Roof Vents ...	44
Install Circular Vent .....	48
Install Side and Roof Panels .....	49
Install Weather Stripping .....	50
Install Trim Plates .....	51
Weather Strip and Hang Doors .....	53
Secure to Ground .....	54
Install Trays and Bin Holder .....	55

# General Order of Assembly

- Step 1: Assemble Back
- Step 2: Assemble Doors
- Step 3: Assemble Front
- Step 4: Assemble Sides
- Step 5: Prepare Shelves
- Step 6: Connect Sides to Back
- Step 7: Connect Sides to Front
- Step 8: Assemble and Connect Gables
- Step 9: Brace Sides
- Step 10: Assemble and Install Roof Vents
- Step 11: Install Circular Vent
- Step 12: Install Side and Roof Panels
- Step 13: Weather Stripping
- Step 14: Install Trim Plates
- Step 15: Weather Strip and Hang Doors
- Step 16: Secure to Ground
- Step 17: Install Trays and Bin Holder

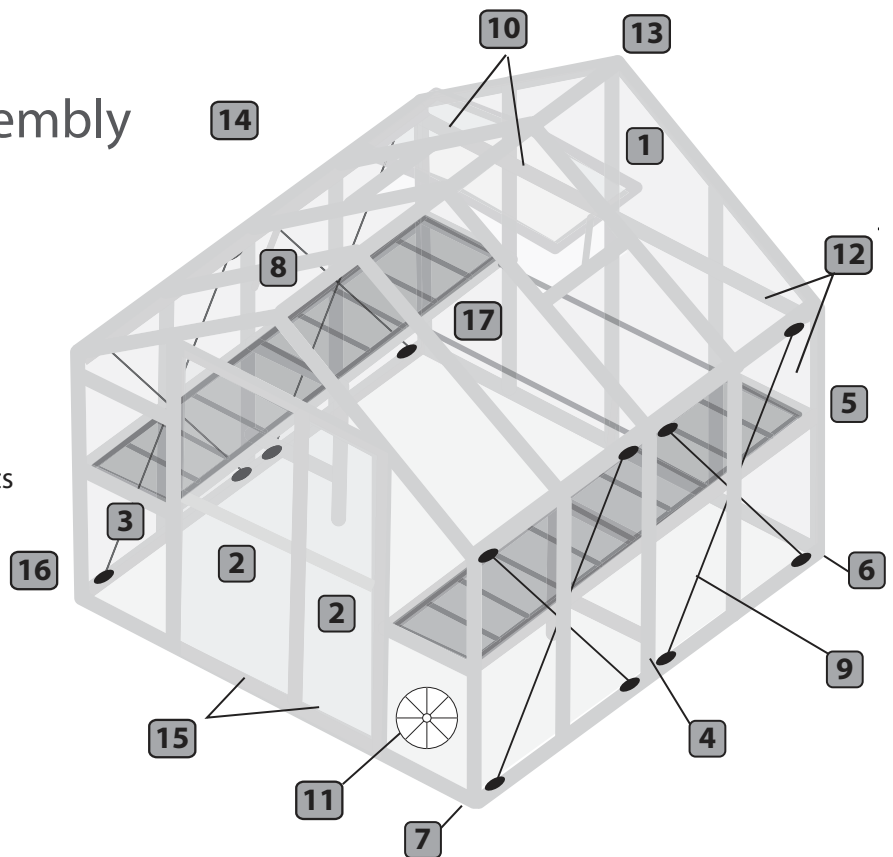

# List of Parts



The greenhouse is shipped in two cartons. These cartons are heavy. Be careful when lifting them. Wear proper safety gear including work shoes, gloves and goggles.

The parts are identified by removable stickers.











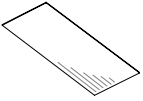

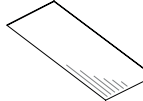

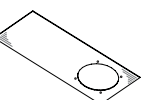

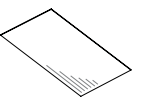

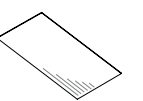

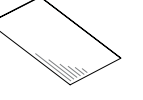

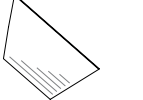

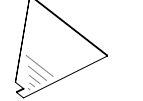

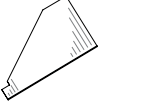

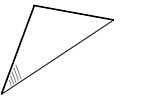

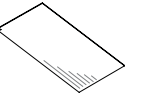

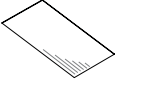
Place all the parts for each step in staging areas, checking that you have all parts as you go.

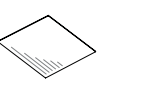

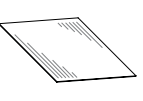

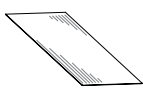

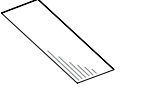



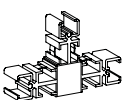

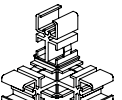
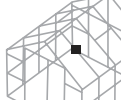
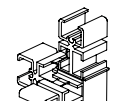

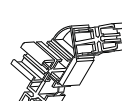
If any parts are missing or damaged, contact STC customer service before beginning assembly:

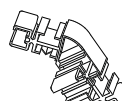
Customer Service: (877) 407-9100 ext. 1 or email: [customerservice@stcaustin.com](mailto:customerservice@stcaustin.com)

Profile	QTY		
	L01C	4	Step 4
	L01I	1	Step 1
	L01J	1	Step 1
	L01K	1	Step 3
	L01L	1	Step 3
	L02A	2	Steps 1,3
	L02B	2	Steps 1,3
	L02G	2	Step 8
	L02I	1	Step 1
	L02J	1	Step 1
	L02K	1	Step 3
	L02L	1	Step 3
	L03A	2	Step 4
	L03B	4	Step 4
	L03C	1	Step 1
	L03D	1	Step 1
	L03K	1	Step 1
	L03L	1	Step 1
	L03M	2	Step 8
	L03N	1	Step 8
	L03O	1	Step 8
	L03P	1	Step 8
	L03Q	1	Step 8
	L04A	2	Step 3
	L04B	2	Step 4
	L04C	2	Step 4
	L04D	2	Step 4
	L04G	2	Step 17
	L04F	2	Step 1
	L05A	2	Step 1
	L05C	2	Step 3
	L05D	1	Step 10
	L05F	1	Step 2
	L05G	1	Step 10
	L05H	2	Step 1
	L05I	1	Step 2

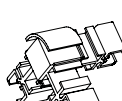
Profile	QTY		
	L06A	1	Step 3
	L06J	1	Step 3
	L06K	1	Step 3
	L07A	2	Step 4
	L07B	2	Step 4
	L08A	1	Step 8
	L08B	1	Step 8
	L10A	2	Step 10
	L11A	2	Step 10
	L12B	4	Step 10
	L13B	1	Step 2
	L13C	1	Step 2
	L13D	1	Step 2
	L13E	2	Step 2
	L13G	1	Step 2
	L13H	1	Step 2
	L13F	1	Step 2
	L14A	2	Step 5
	L14B	2	Step 5
	L14C	2	Step 5
	L14D	2	Step 5

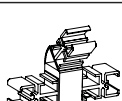
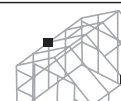
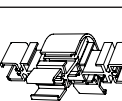
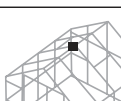
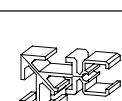
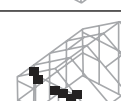
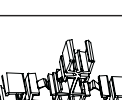
Panel		QTY		
		Y1	2	Step 1
		Y5	1	Step 3
		Y6	1	Step 3
		Y9	4	Step 12
		Y10	4	Step 12
		Y16	2	Step 1
		Y17	2	Step 1
		Y18	2	Step 1
		Y19	2	Step 3
		Y20	1	Step 3
		Y21	4	Step 12
		Y22	2	Step 12
		Y23	2	Step 12
		Y24	2	Step 10
		Y25	2	Step 2
		Y26	2	Step 2

Connector		QTY		
		S03	4	Step 4
		S04	2	Steps 1,3
		S05	2	Steps 1,3
		S09	2	Steps 1,3
		S10	2	Steps 1,3
		S12	1	Step 1
		S18	1	Step 3
		S19	2	Step 4
		S21	1	Step 8
		S28	10	Steps 2,3
		S39	2	Step 4

Trim Plate		QTY		
	L09A	2	Step 14	
	L09B	2	Step 14	
	J02L	2	Step 14	
	J02R	2	Step 14	
	J03	2	Step 14	
	J06	1	Step 14	
	rubber stripping	J01A	80M	Steps 13,15

Shelf Trays		QTY		
	J05	20	Step 17	

Circular Vent		QTY		
	circular vent	1	Step 11	
	vent frame	1	Step 11	
	plastic nut	4	Step 11	

Door Handle		QTY		
	S29	1	Step 2	
	S30	1	Step 2	
	S31	2	Step 2	
	S32	1	Step 2	
	S33	1	Step 2	

Door Lock		QTY		
	S40	2	Step 2	
	S40A	4	Step 2	

Roof Vent Handle		QTY		
	S25	1	Step 10	

Auto Vent Opener		QTY		
	S41	1	Step 10	
	S41A	2	Step 10	
	Hair Pin Clip	1	Step 10	

Connector		QTY		
	S02	162	Steps 1,2,3,4,8	
	S13	17	Steps 1,2,10	
	S14	17	Steps 1,2,10	
	S24	2	Step 10	
	S24A	2	Step 10	
	S26	8	Step 10	
	S36	4	Step 17	

Bracing Parts		QTY		
	S06	24	Steps 1,3,9	
	S07	8	Step 9	
	S16	4	Steps 1,3	
	hex key	1	Steps 1,3,9	
	S23	3	Step 8	
	L15A	1	Step 2	

Anchor Clip and Peg		QTY		
	S34	6	Step 16	
	S35	6	Step 16	

Connector		QTY		
	S01	16	Steps 1,3,4	
	S08	7	Steps 2,4	
	S08C	1	Step 3	
	S11	3	Step 1	
	S17L	1	Step 3	
	S17R	1	Step 3	
	S20	4	Step 4	
	S22	2	Step 8	
	S37	12	Steps 5,17	
	L16	3	Steps 1,3	

# Assemble Back

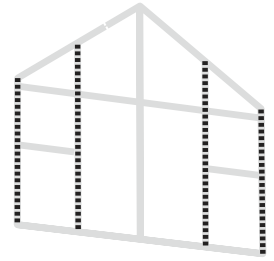

Place all the parts for the back face on a level surface.  
 Make sure the pieces are in the correct positions before assembling.  
 Carefully follow the order of assembly to ensure an easy installation.  
 Wear proper safety gear including work shoes, gloves and goggles.



The back is assembled with the outside face to the ground. ALL VIEWS ARE SHOWN FROM INSIDE.

**1.1A** Slide short side of connector S01 into channels of profiles L02A and L02B.  
 Line up last hole on connector S01 with hole in each profile.

**IMPORTANT:** The holes are not at the midpoint of the profile.  
 Arrange profile so the 28" portion will be the bottom when standing.

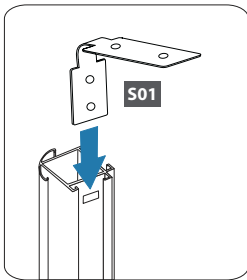

**1.1B** Secure with S02 screws.

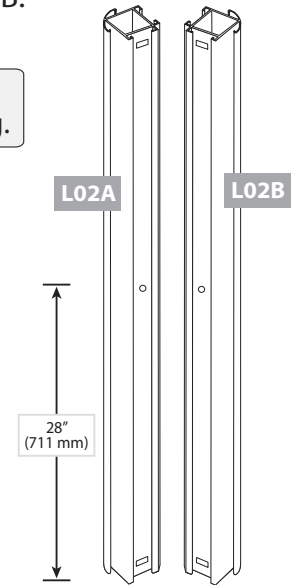
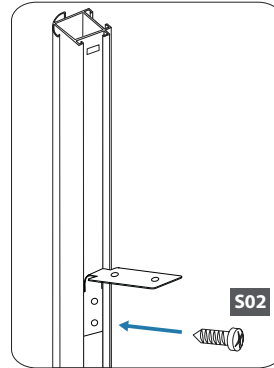

**1.2A** Line up bottom hole on short side of connectors S01 with hole on side of profiles L03C and L03D.

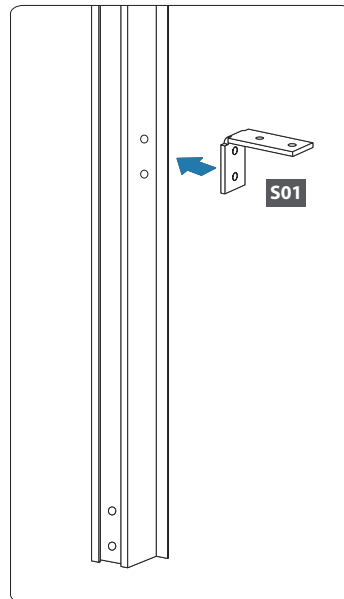
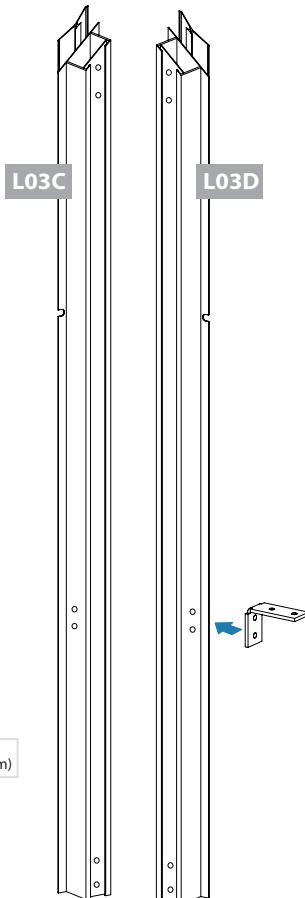

**1.2B** Secure with S02 screws.

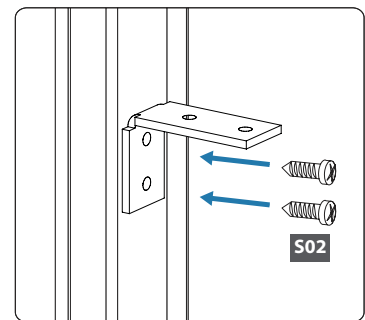

**NOTE: ALL VIEWS ARE FROM INSIDE.**

Profile	QTY	Profile	QTY	Connector	QTY
#L02A	1	#L03C	1	#S01	4
#L02B	1	#L03D	1	#S02	6



**1.3A**

Attach profiles L02B and L03C to profile L04F by sliding the long sides of connector S01 into channels lining up last hole in S01 with holes in profile L04F. Attach profiles L03D and L02A to profile L04F by sliding the long side of connector S01 into profile channels lining up last hole of S01 with holes in L04F.

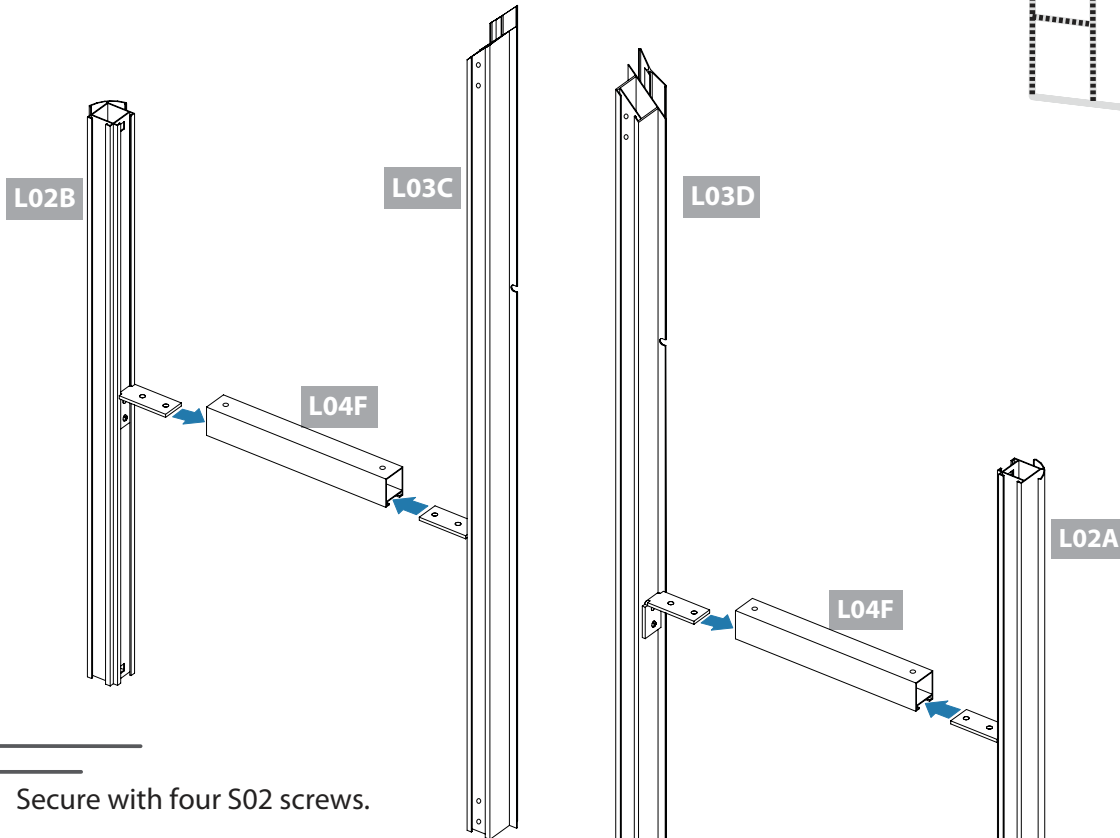
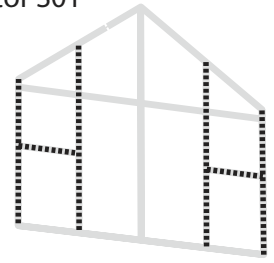

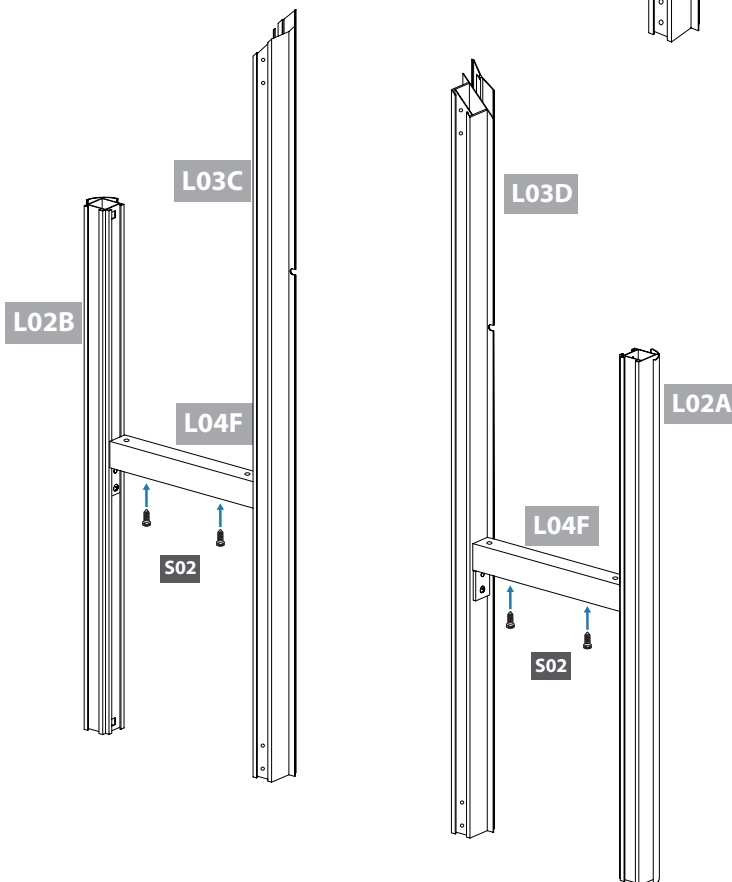

**1.3B**

Secure with four S02 screws.

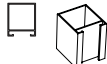

NOTE: ALL VIEWS ARE FROM INSIDE.

Profile	QTY	Screw	QTY
 #L04F	2	 #S02	4

**1.4A**

Slide connector L16 inside profiles L03L and L03K. The two end holes on each side of connector L16 line up with the two holes on each profile.

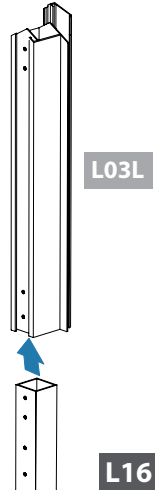

**1.4B**

Secure with four S02 screws.

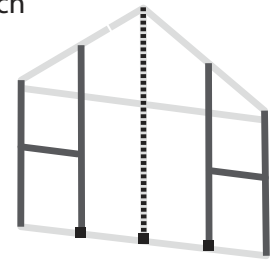
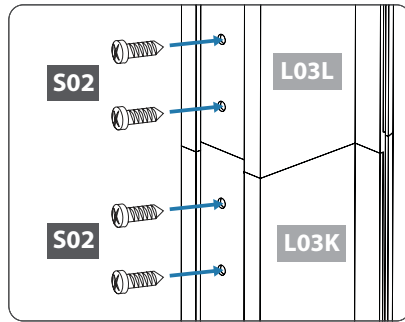

Profile		QTY	Connector		QTY
	#L03K	1		#L16	1
	#L03L	1		#S02	4

**1.5A**

Slide connectors S08 into channels of profiles L03C, L03D and L03K.

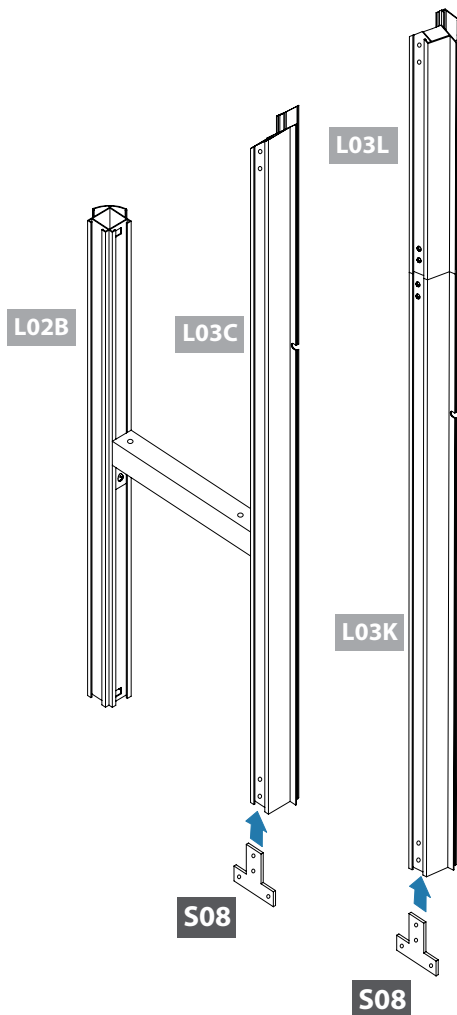

**1.5B**

Secure each connector with two S02 screws.

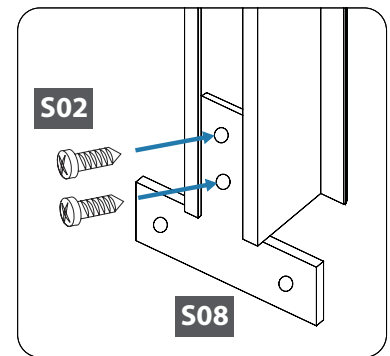

NOTE: ALL VIEWS ARE FROM INSIDE

Connector		QTY
	#S02	6
	#S08	3

**1.6A** Slide connector L16 inside profiles L01I and L01J.

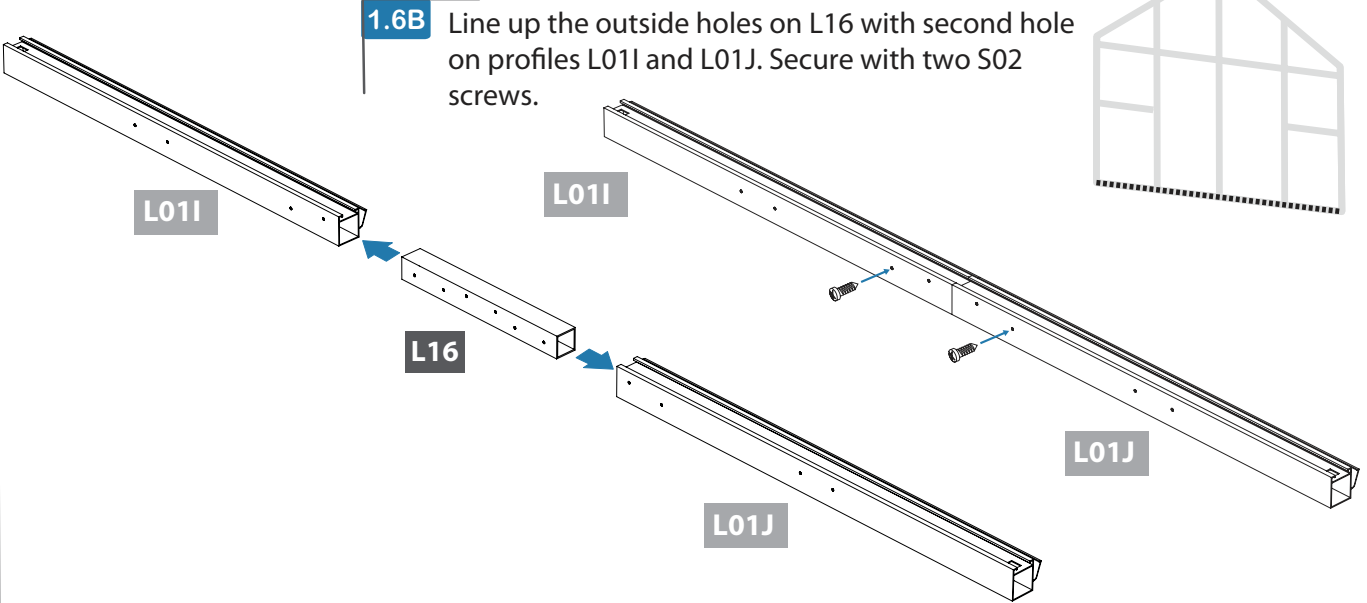

**1.6B** Line up the outside holes on L16 with second hole on profiles L01I and L01J. Secure with two S02 screws.

NOTE: ALL VIEWS ARE FROM INSIDE

Profile	QTY	Connector	QTY
#L01I	1	#L16	1
#L01J	1	#S02	2

**1.6C** Slide connectors S04 into profile L01I and connector S05 into profile L01J until they securely click into place.

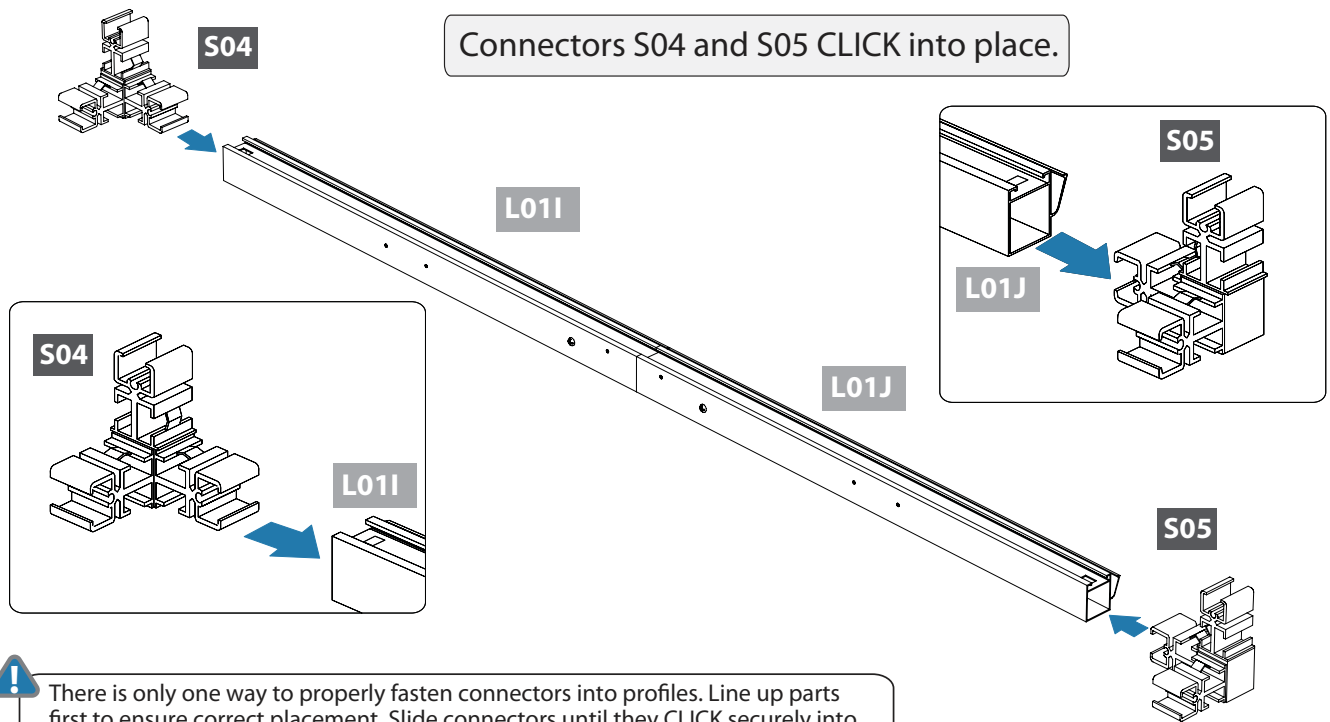

**!** There is only one way to properly fasten connectors into profiles. Line up parts first to ensure correct placement. Slide connectors until they CLICK securely into profile. Use WD40 or liquid soap if pieces do not easily slide together. Wear gloves.

Connector	QTY	Connector	QTY
#S04	1	#S05	1

**1.7A** Carefully line up connector S04 with profile L02B and connector S05 with profile L02A. Slide profiles L011 and L01J half way into place. Continue sliding until connectors S04 and S05 click securely into profiles.

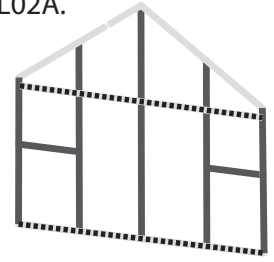

**NOTE: ALL VIEWS ARE FROM INSIDE.**

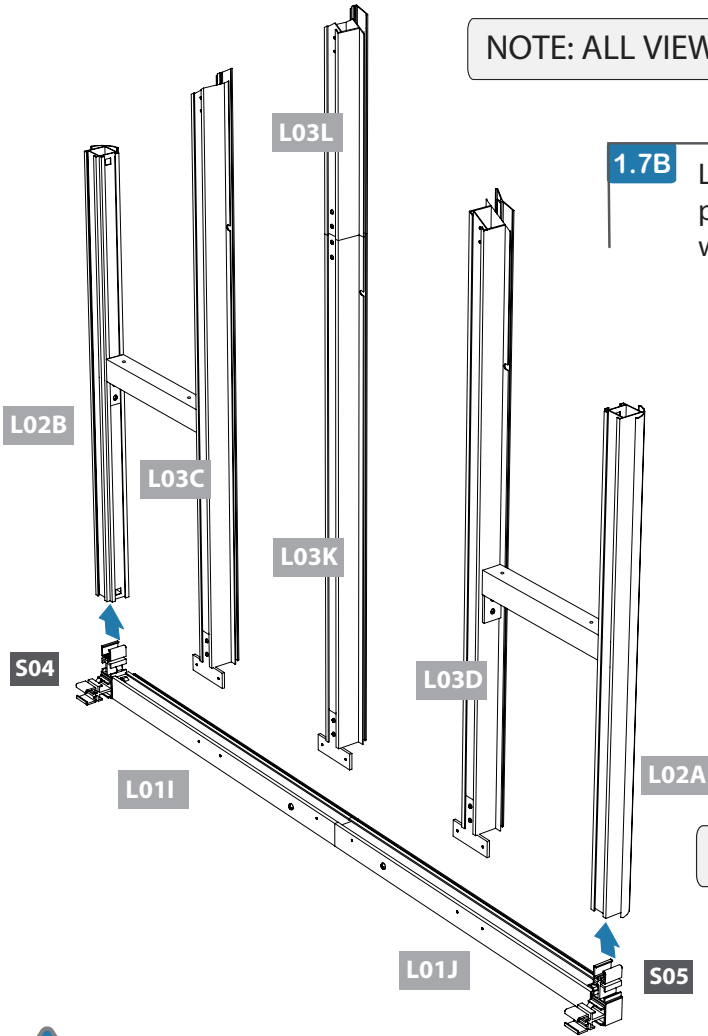

**1.7B** Line up holes on connectors S08 with holes in profiles L011 and L01J. Secure each connector with two S02 screws.

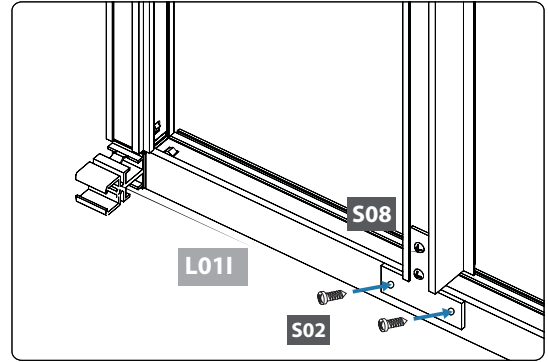

**Connectors S04 and S05 CLICK into place.**

**!** There is only one way to properly fasten connectors into profiles. Line up parts first to ensure correct placement. Slide connectors until they **CLICK** securely into profile. Use WD40 or liquid soap if pieces do not easily slide together. Wear gloves.

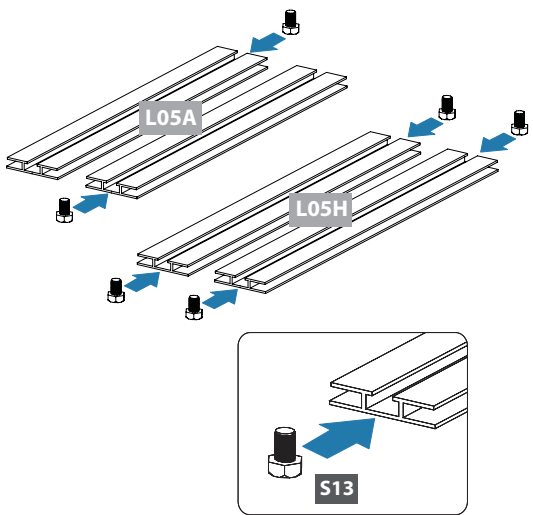

Screw		QTY
	#S02	6

**1.8A** Slide hex bolt S13 into channels of profiles L05A and L05H as shown.

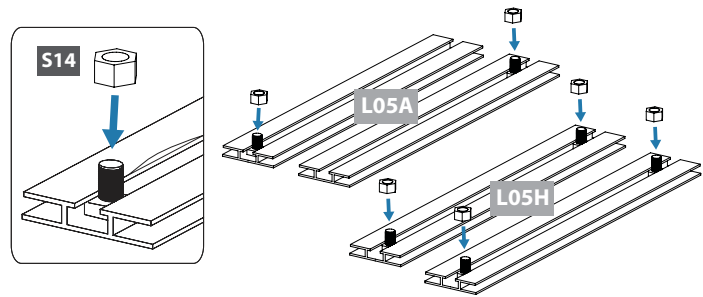

**1.8B** Screw hex nut S14 onto bolt. Do not completely tighten.

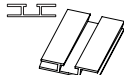

Profile	QTY	Nut / Bolt	QTY
 #L05A	2		#S13 6
#L05H	2		#S14 6

**1.9A**

Remove protective plastic from both sides of panels Y1, Y16, Y17 and Y18. Place side to face toward the sun facing down. Fit panels Y1 and Y16 into bottom channel of profiles L05A and L05H.

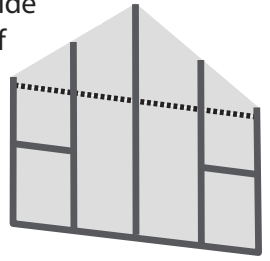
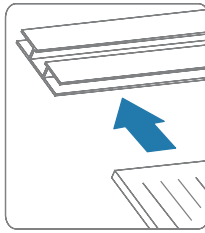
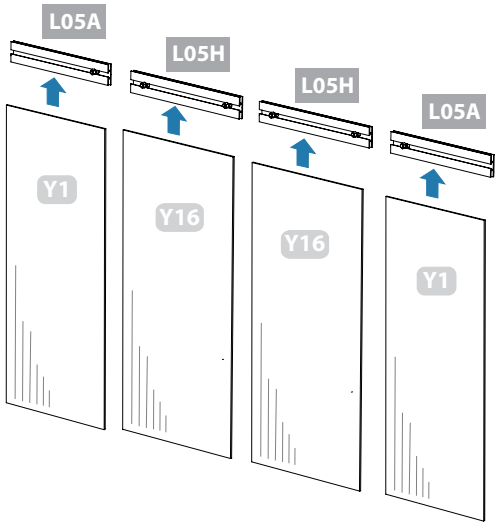

**!** Remove protective plastic from EACH side of poly carbonate panels before installing. Dispose of plastic properly. Install with side labeled "Face this side towards the sun" FACING DOWN.

NOTE: ALL VIEWS ARE FROM INSIDE.

**1.9C**

Slide panels Y17 and Y18 into V-channels on profiles L02A, L02B, L03C, L03D and L03L. Fit inside channels on profiles L05A and L05H.

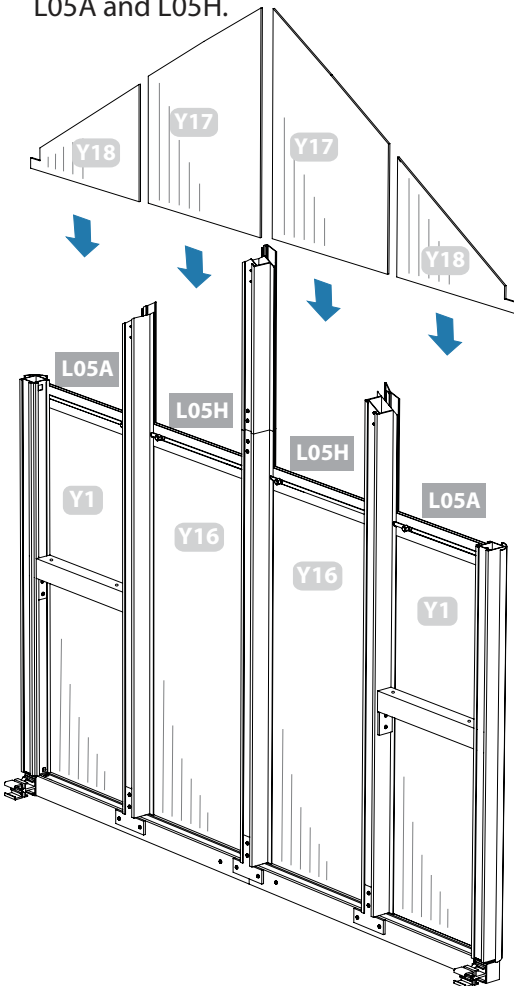

**1.9B**

Slide panels and profiles L05A and L05H into V-channels on profiles L02A, L02B, L03C, L03D and L03L.

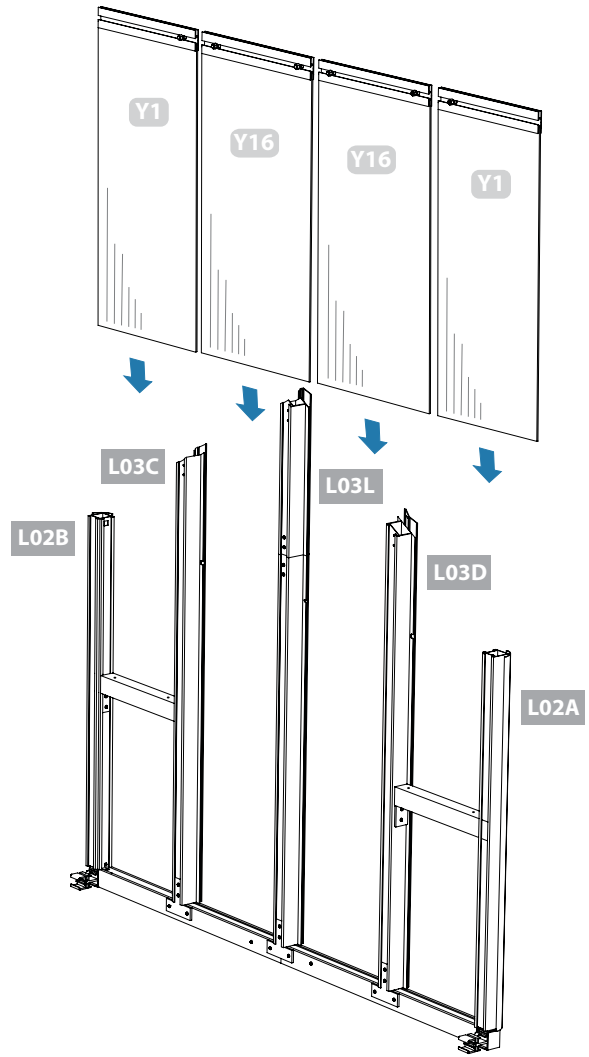

Panel	QTY	Panel	QTY
	#Y1 2		#Y17 2
	#Y16 2		#Y18 2

**1.10** Slide hex nut S14 and hex bolts S13 into U-cutout in both sides of profiles L03C, L03D and L03K. Tighten securely to hold in place.

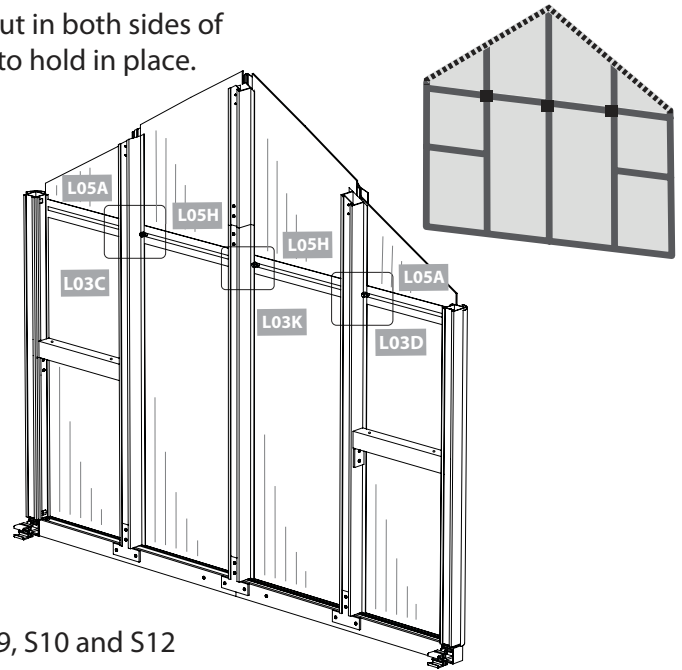
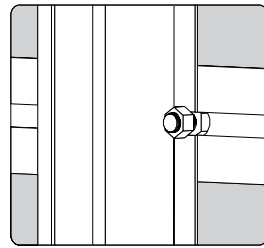
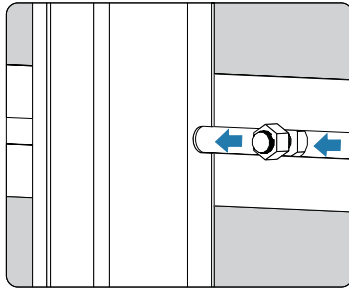

NOTE: ALL VIEWS ARE FROM INSIDE.

**1.11A** Slide profiles L02I and L02J into connectors S09, S10 and S12 until they click into place.

Connectors S09, S10 and S12 CLICK into place.

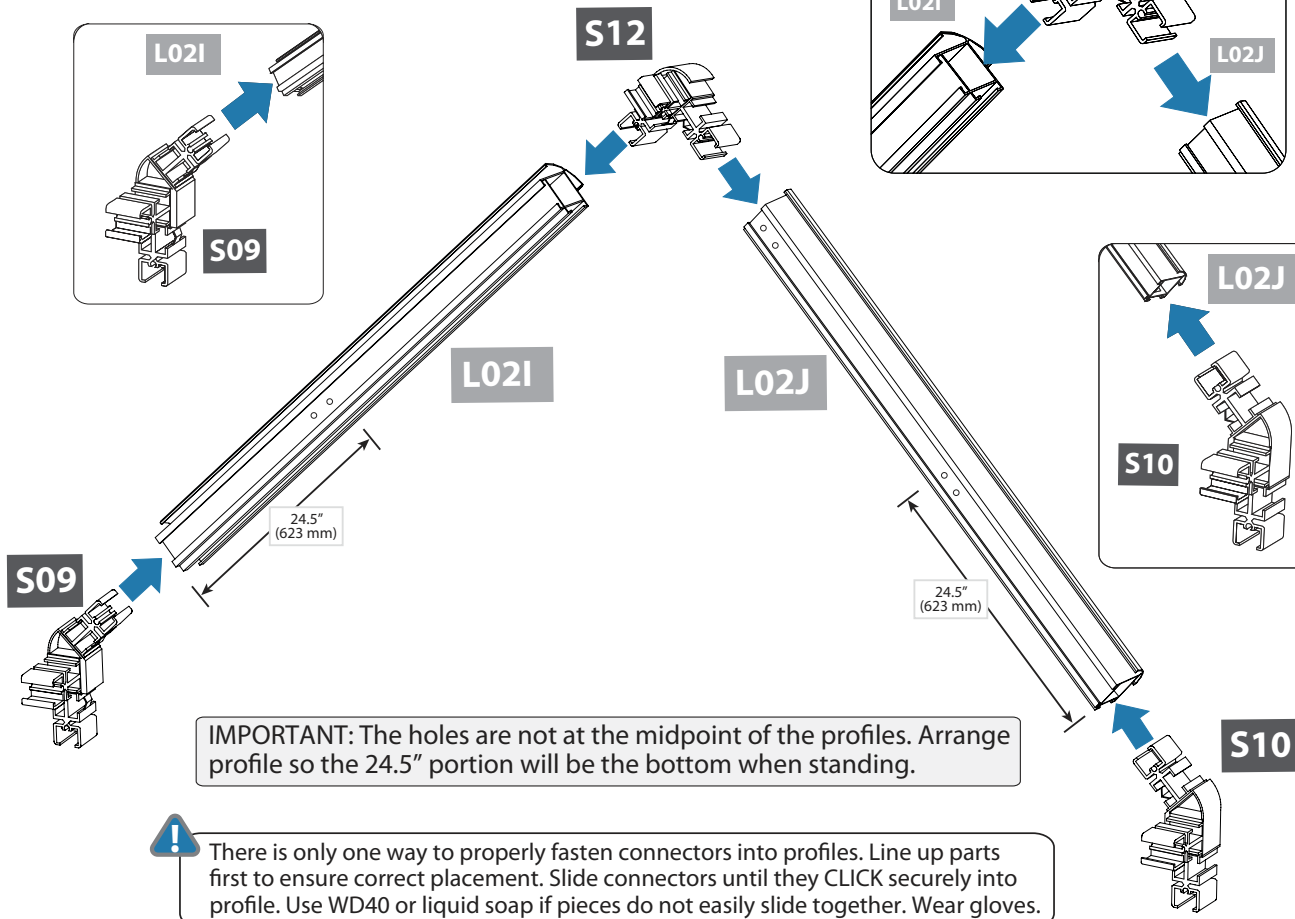
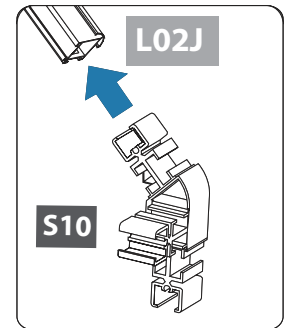
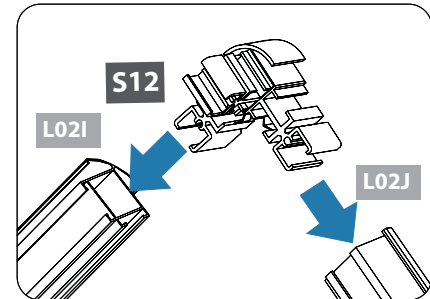
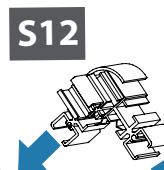
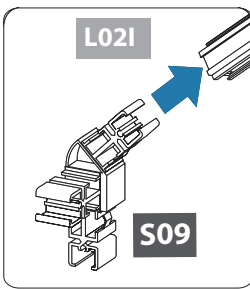

**IMPORTANT:** The holes are not at the midpoint of the profiles. Arrange profile so the 24.5" portion will be the bottom when standing.

**!** There is only one way to properly fasten connectors into profiles. Line up parts first to ensure correct placement. Slide connectors until they CLICK securely into profile. Use WD40 or liquid soap if pieces do not easily slide together. Wear gloves.

Profile	QTY	Connector	QTY	Connector	QTY	Connector	QTY
#L02I	1	#S09	1	#S10	1	#S12	1
#L02J	1						

**1.11B**

Slide connectors S09 and S10 half way into profiles L02A and L02B. Continue sliding together making sure panels Y17 and Y18 fit into V-channels of profiles L02I and L02J. Connectors click securely into profiles.

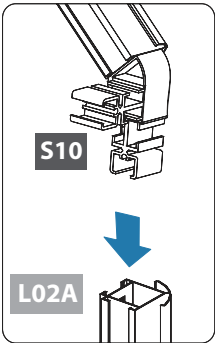
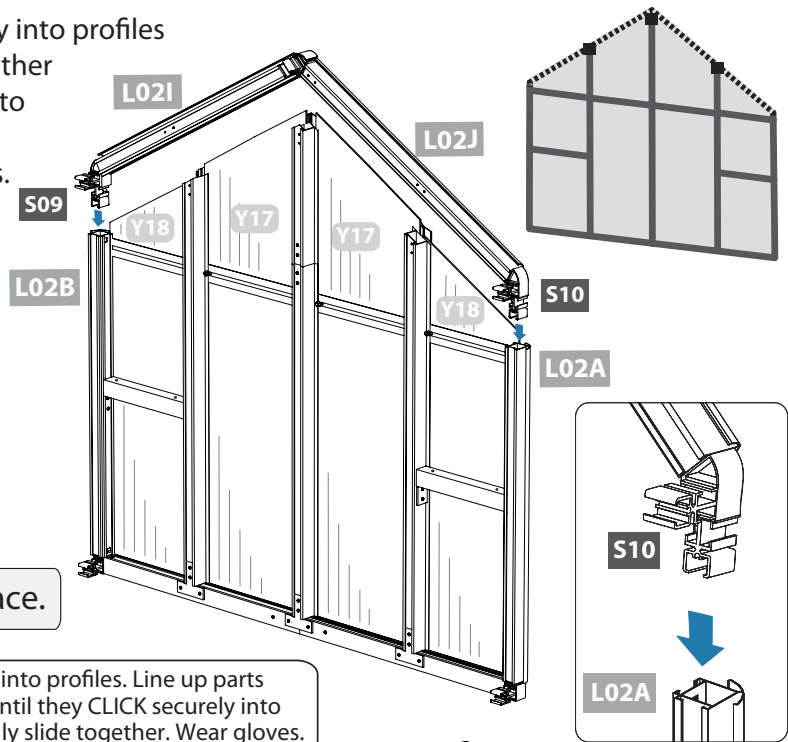
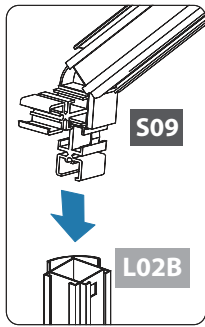

Connectors S09 and S10 CLICK into place.

**!** There is only one way to properly fasten connectors into profiles. Line up parts first to ensure correct placement. Slide connectors until they CLICK securely into profile. Use WD40 or liquid soap if pieces do not easily slide together. Wear gloves.

**1.12A**

Place connectors S11 onto profiles L02I and L03C, L02J and L03L and L02J and L03D matching up all holes.

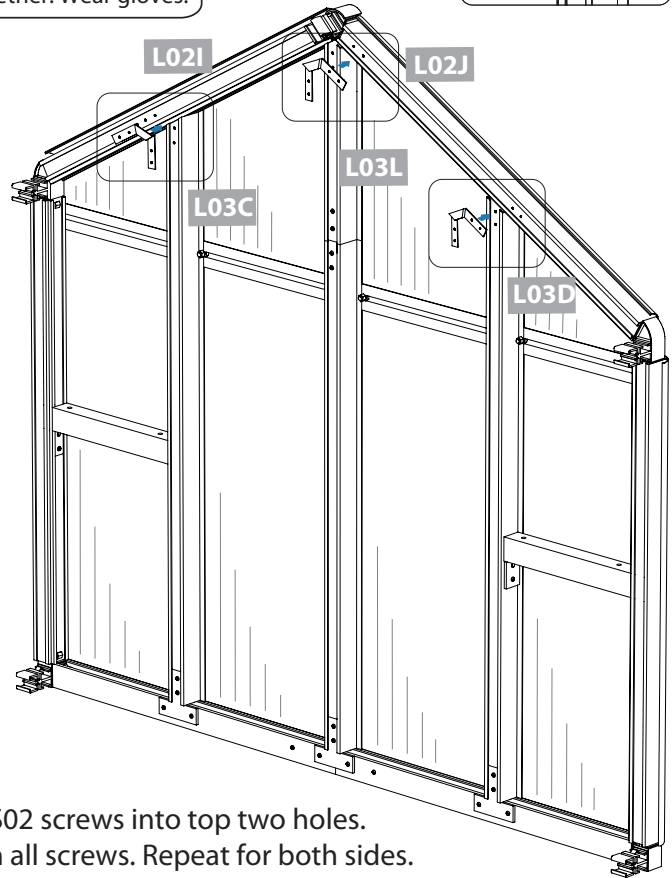

**1.12B**

Screw S02 screws partially into bottom two holes. Do not tighten.

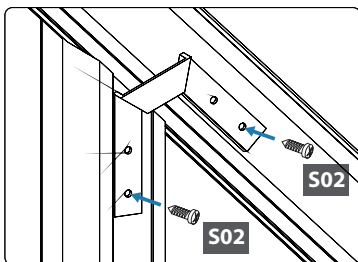

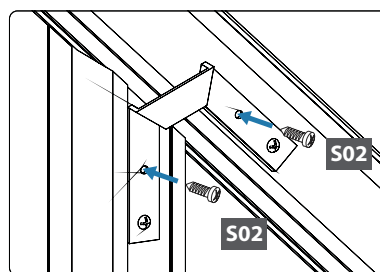

**1.12C**

Screw S02 screws into top two holes. Tighten all screws. Repeat for both sides.



NOTE: ALL VIEWS ARE FROM INSIDE.

Connector		QTY
	#S02	12
	#S11	3

**1.13A** Insert long side of cable connector S06 at an angle into profile channel L02B with HOOK FACING UP. Slide connector to other side of channel. Use hex key to securely tighten and hold in place.

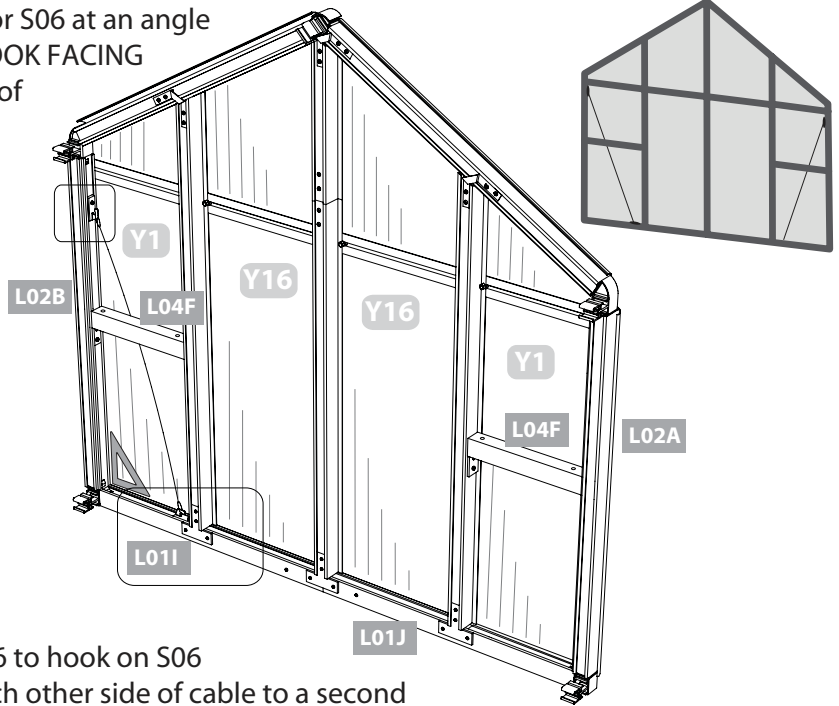
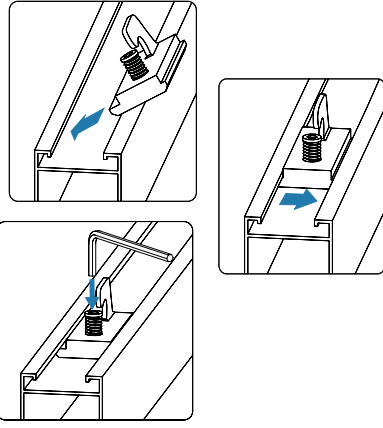

**1.13B** Attach one side of short cable S16 to hook on S06 and lace under profile L04F. Attach other side of cable to a second S06 cable connector and with hook facing center, insert into profile channel L01I. Push the S06 connector towards center until profile corners are square and cable is tight. Use hex key to securely tighten and hold in place.

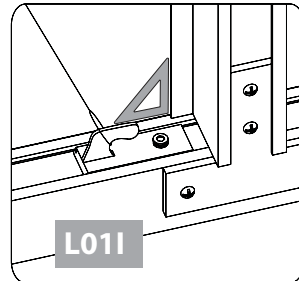
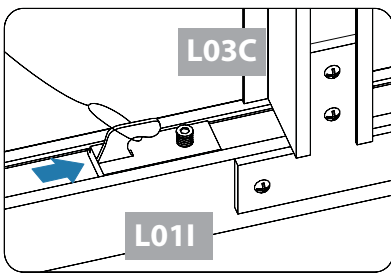

**IMPORTANT:** Make sure all corners are squared at 90 degrees.

**NOTE:** ALL VIEWS ARE FROM INSIDE.

**1.14** Repeat step 1.13 inserting cable connectors S06 into profiles L02A and L01J. Cable rests next to panel Y1, under profile L04F. Slide connector until profile corners are square and cable is tight. Use hex key to securely tighten second connector and hold in place.

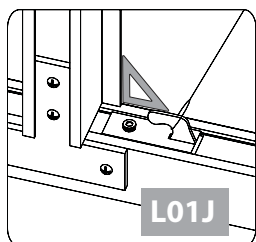
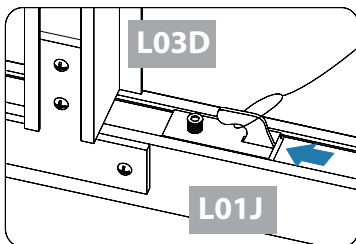

**IMPORTANT:** Make sure all corners are squared at 90 degrees.

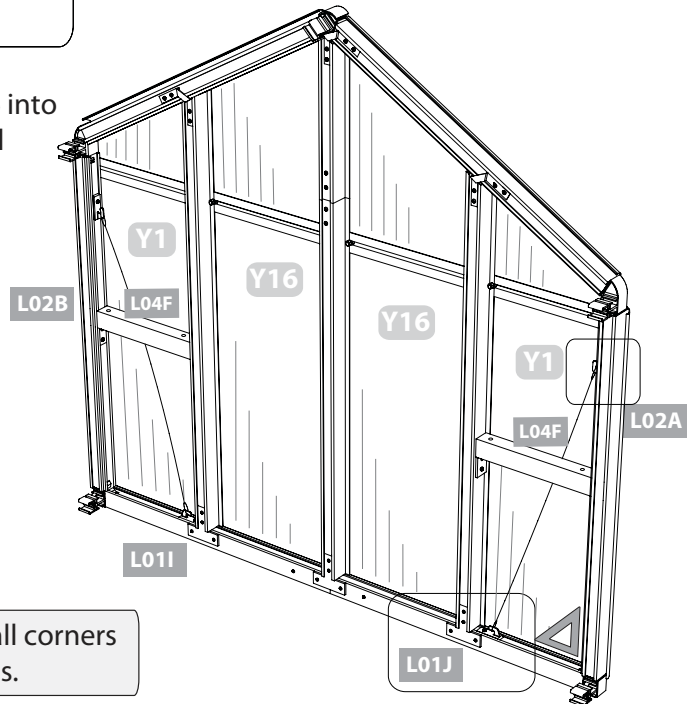

Hex Key	QTY	Cable Connector	QTY	Cable	QTY
	1		4		2
		#S06		#S16	



# Assemble Doors

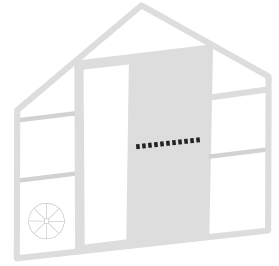

Place all the parts for both doors on a level surface. Make sure the pieces are in the correct positions before assembling. Carefully follow the order of assembly to ensure an easy installation. Wear proper safety gear including work shoes, gloves and goggles.



Both doors are assembled with the outside face to the ground. ALL VIEWS ARE SHOWN FROM INSIDE.

2.1A

Slide three hex bolts S13 into channel of profile L05I.

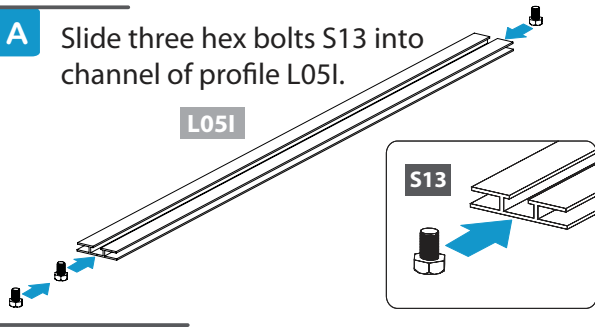

2.1B

Screw two S14 hex nuts onto bolt on each end. Do not completely tighten.

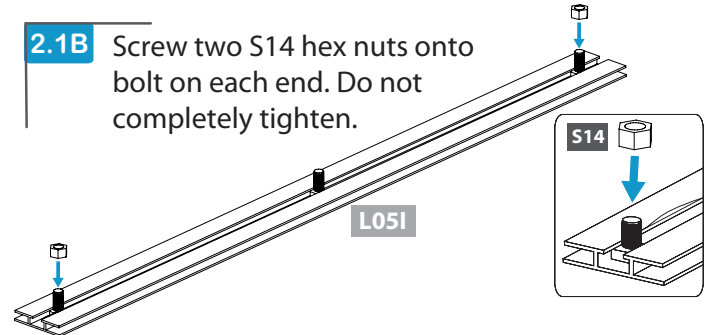

2.2

Remove protective plastic from both sides of panels Y25. Place side to face toward the sun facing down. Fit panels into channels of profile L05I.

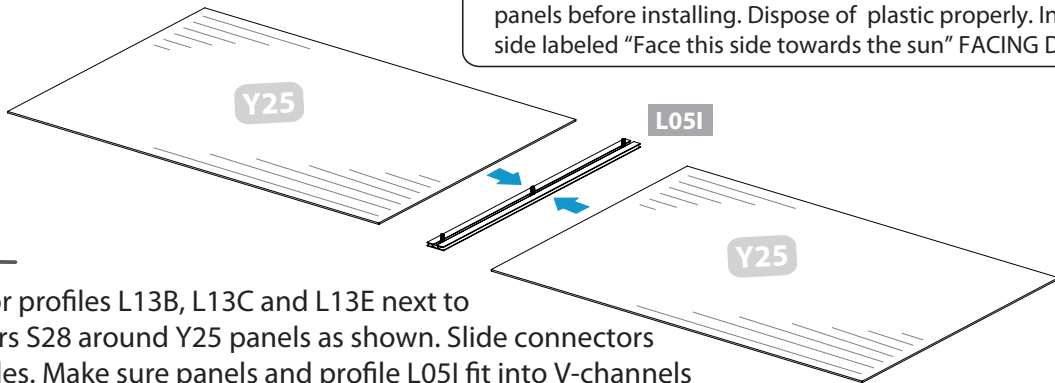
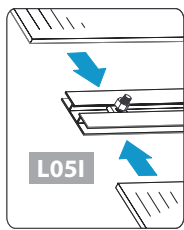

Remove protective plastic from EACH side of poly carbonate panels before installing. Dispose of plastic properly. Install with side labeled "Face this side towards the sun" FACING DOWN.

2.3

Place door profiles L13B, L13C and L13E next to connectors S28 around Y25 panels as shown. Slide connectors into profiles. Make sure panels and profile L05I fit into V-channels of each profile. S28 connectors will be secured to profiles in Step 2.4

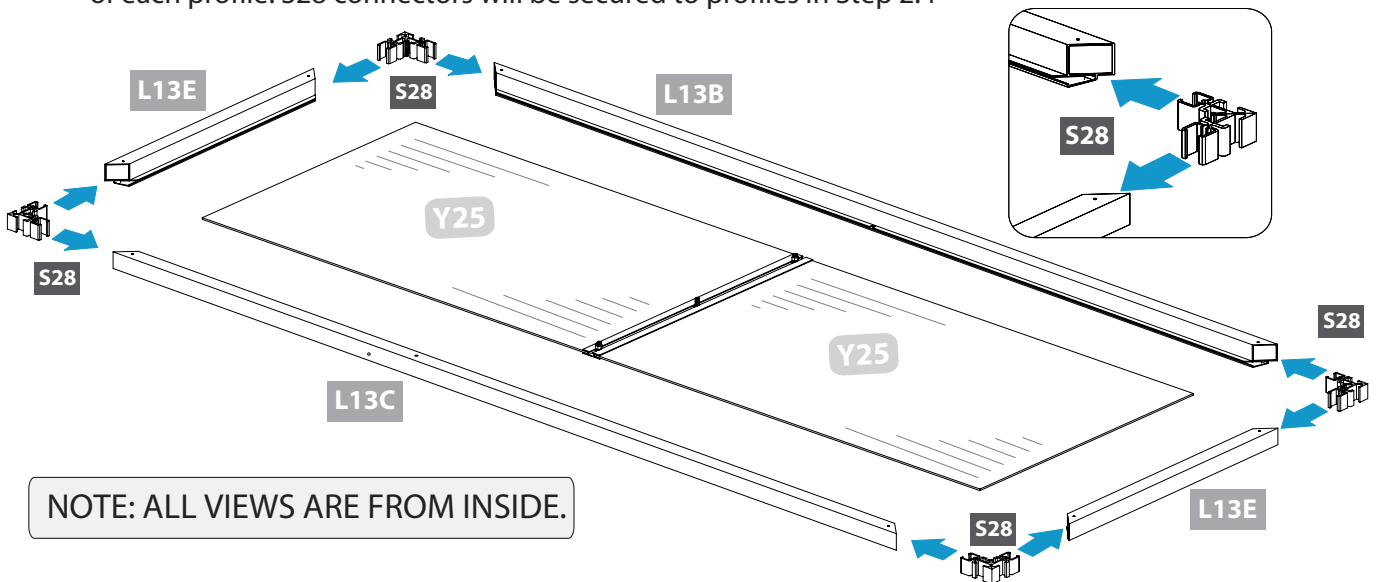

NOTE: ALL VIEWS ARE FROM INSIDE.

Panel	QTY	Profile	QTY	Bolt / Nut	QTY	Profile	QTY	Connector	QTY					
	#Y25	2		#L05I	1		#S13	3		#L13B	1		#S28	4
							#S14	2		#L13C	1			
										#L13E	2			

**2.4A** Slide hex nuts and bolts into U-cutout in side of profiles L13B and L13C. Tighten securely to hold in place.

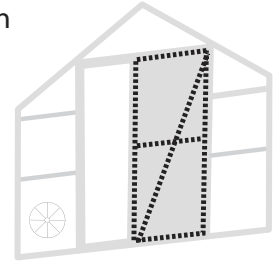
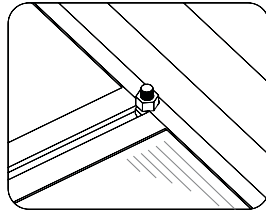
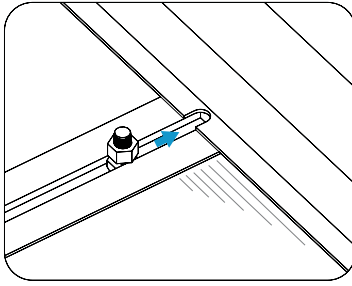

**NOTE:** The holes at the top of profile L13B and the bottom left corner of profile L13E will be secured in Step 2.5.

**2.4B** Secure connectors with six S02 screws.

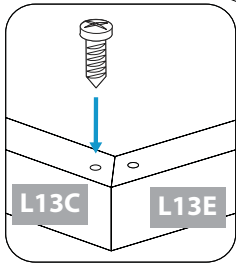
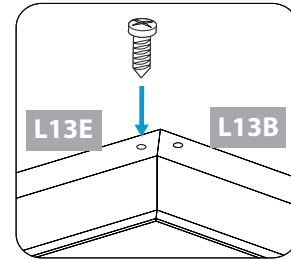
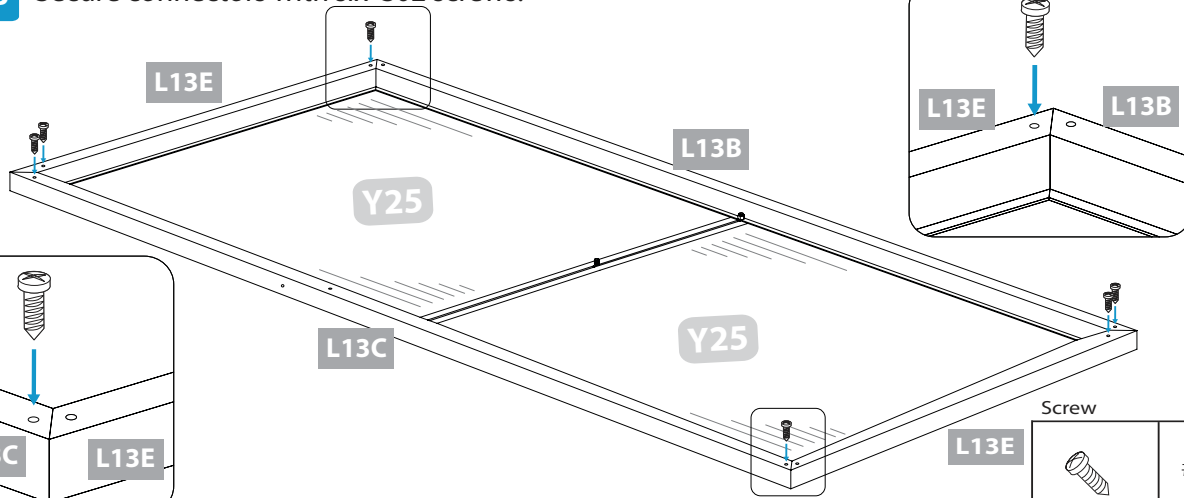

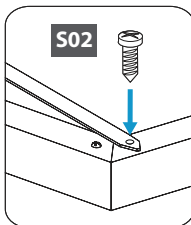
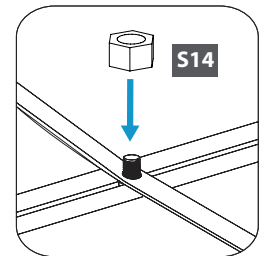
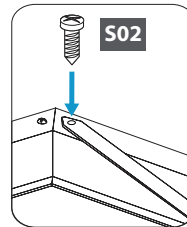
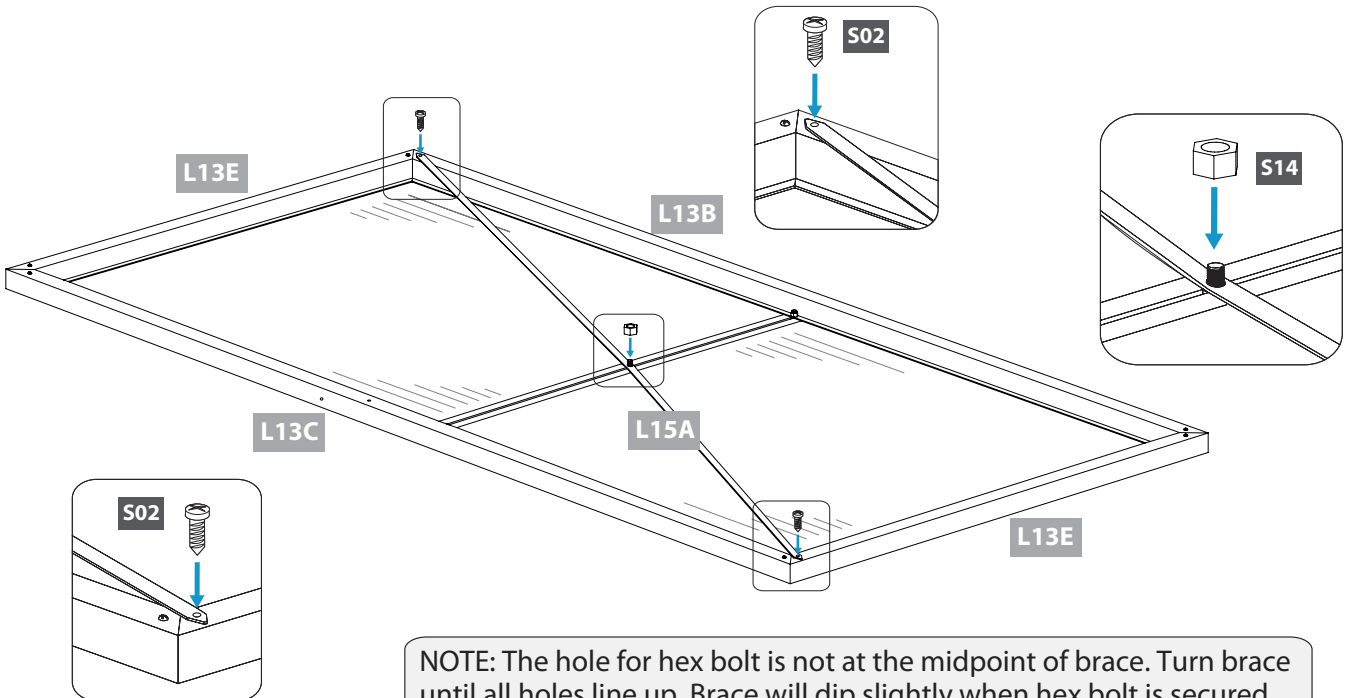

Screw	QTY
 #S02	6

**2.5** Place brace L15A onto door lining up the holes on each end with the holes in profiles L13E and L13B. Slide hex bolt so it fits through hole in brace. Secure brace with two S02 screws and S14 hex nut.

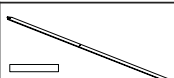

**NOTE:** The hole for hex bolt is not at the midpoint of brace. Turn brace until all holes line up. Brace will dip slightly when hex bolt is secured.

**NOTE:** ALL VIEWS ARE FROM INSIDE.

Brace	QTY	Screw / Nut	QTY
 #L15A	1		#S02 2
			#S14 1

**2.6A** Open door handle kit and remove parts. Slide pin S29 through handle S30, washer S31 and hole in profile L13C into washer S31.

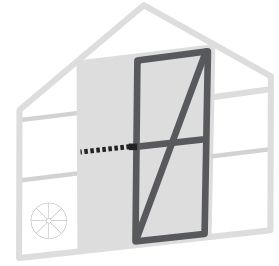
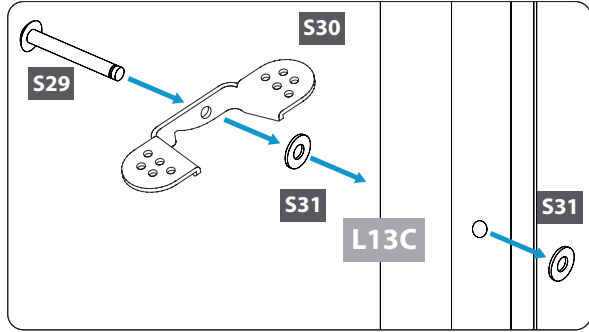

**2.6B** Slide washer S32 into groove on pin S29 to hold securely in place.

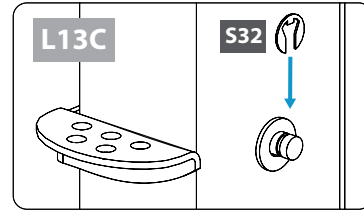

**2.6C** Hook one side of spring S33 into hole on handle S30. Hook the other side into pin hole on profile L13C.

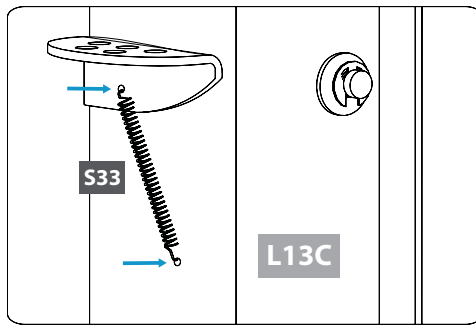

NOTE: Connectors packaged as Door Handle Kit.

Connector		QTY	Connector		QTY
	#S29	1		#S31	2
	#S30	1		#S32	1
				#S33	1

**2.7A** Slide two hex bolts S13 into channel of profile L05F.

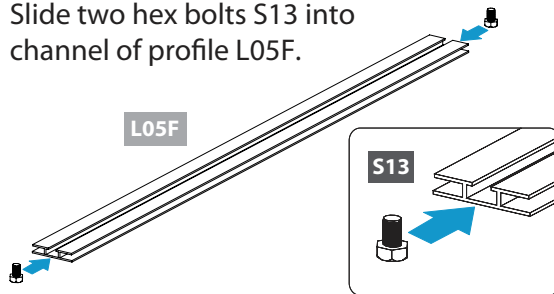

**2.7B** Screw two S14 hex nuts onto bolt on each end. Do not completely tighten.

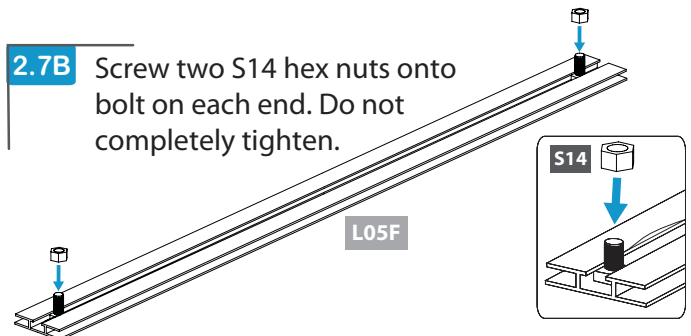

**2.8A** Remove protective plastic from both sides of panels Y26. Place side to face toward the sun facing down. Fit panels into channels of profile L05F.

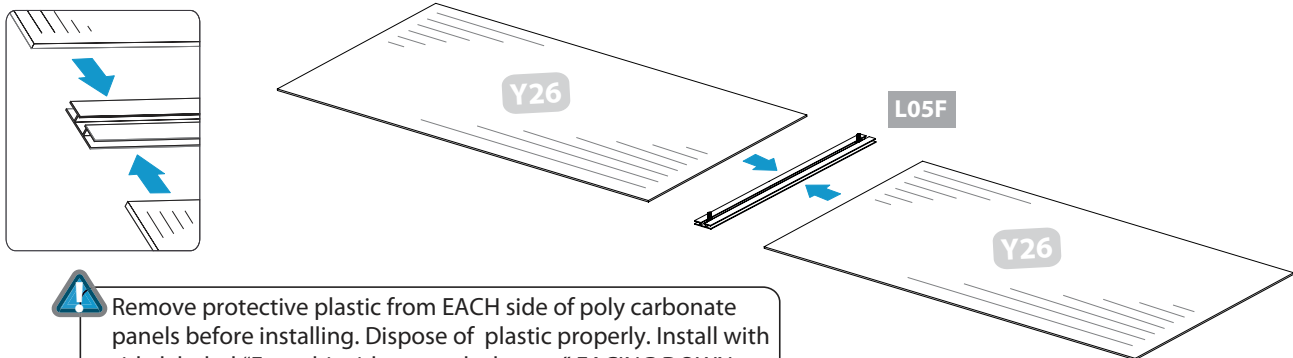

**!** Remove protective plastic from EACH side of poly carbonate panels before installing. Dispose of plastic properly. Install with side labeled "Face this side towards the sun" FACING DOWN.

Panel	QTY	Profile	QTY	Bolt / Nut	QTY
	#Y26	2		#L05F	1
				#S13	2
				#S14	2

**2.8B** Place door profiles L13D, L13F, L13G and L13H next to connectors S28 around Y26 panels as shown. Slide connectors into profiles. Make sure panels and profile L05F fit into V-channels of each profile.

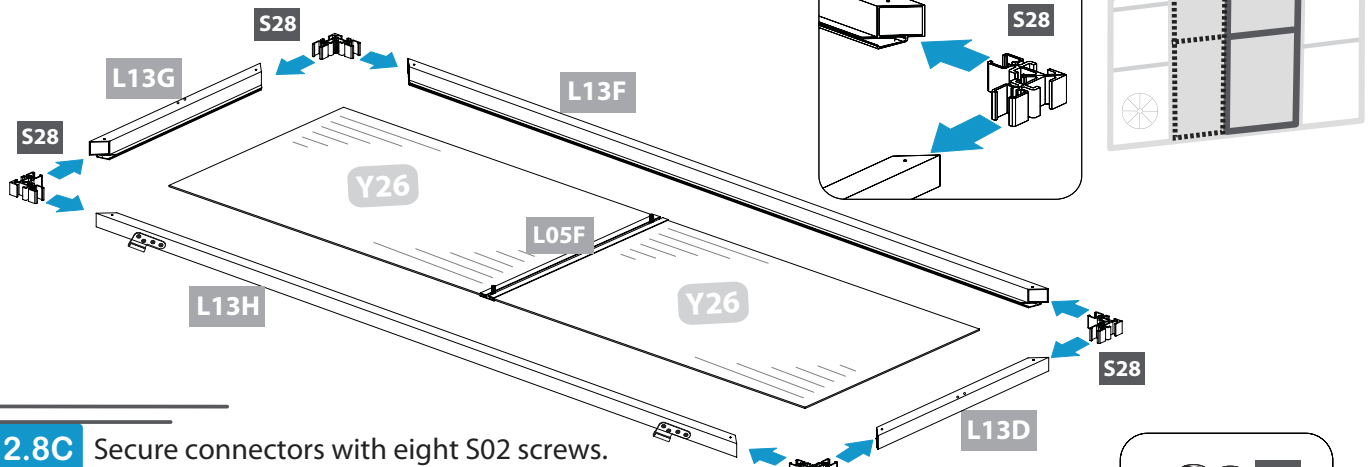

**2.8C** Secure connectors with eight S02 screws.

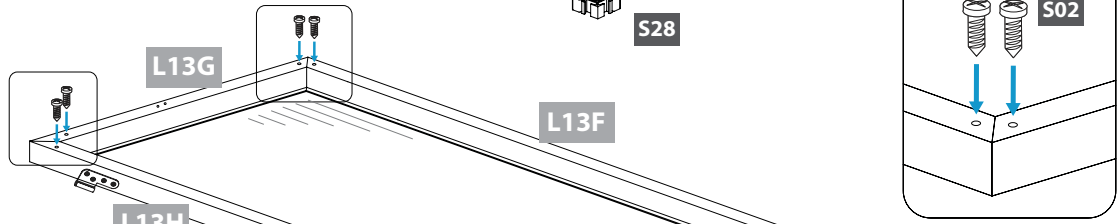

**2.8D** Slide hex nuts and bolts into U-cutout in side of profiles L13F and L13H. Tighten securely to hold in place.

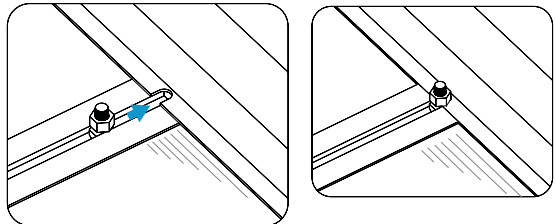

NOTE: ALL VIEWS ARE FROM INSIDE.

**2.9A** Place S40 locks on profiles L13D and L13G as shown. Center the levers so the screw holes are visible.

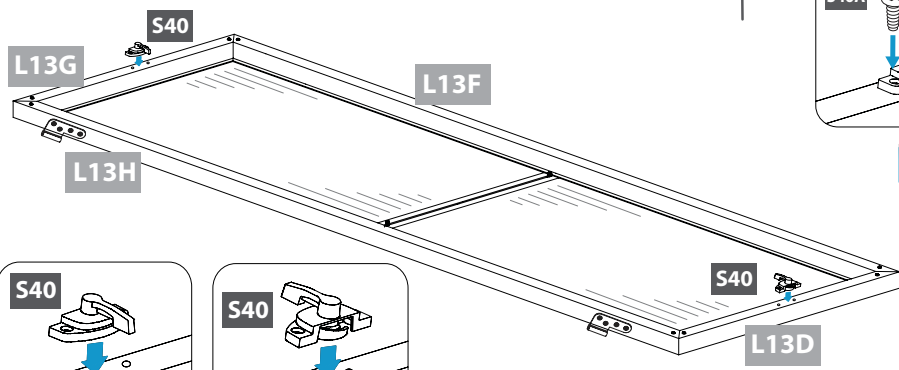

**2.9B** Secure each S40 lock with two S40A screws.

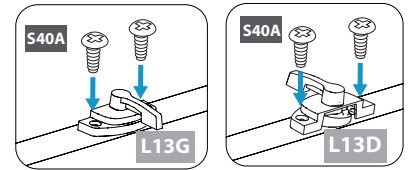

**2.9C** Move lever to the right side to place lock in the unlocked position.

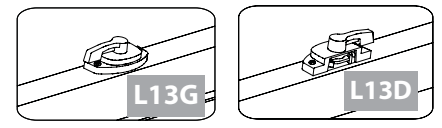

IMPORTANT: Install door locks so levers face the panels.

NOTE: Door locks are shown in the UNLOCKED position. When door is installed in step 15 and door is closed, move lever to the left side to lock door.

Profile	QTY	Profile	QTY	Lock	QTY	Screw	QTY	Connector	QTY					
	#L13F	1		#L13D	1		#S40	2		#S02	8		#S28	4
				#L13G	1		#S40A	4						
				#L13H	1									

# Assemble Front



Place all the parts for the front face on a level surface. Make sure the pieces are in the correct positions before assembling. Carefully follow the order of assembly to ensure an easy installation. Wear proper safety gear including work shoes, gloves and goggles.

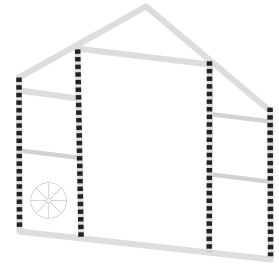

The front is assembled with the outside face to the ground. ALL VIEWS ARE SHOWN FROM INSIDE.

**3.1A** Lay out profiles L02A, L02B, L06A and L06B so all holes line up. Slide short side of connector S01 into channels of profiles L02A, L02B, L06A and L06B.

**IMPORTANT:** The holes are not at the midpoint of the profile. Arrange profile so the 28" portion will be the bottom when standing.

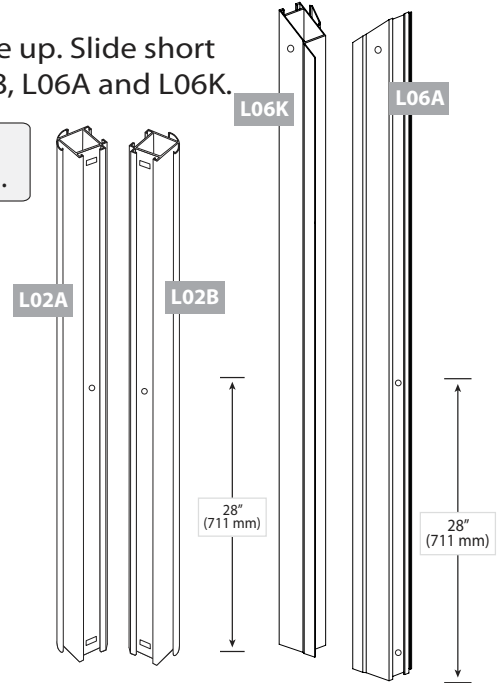
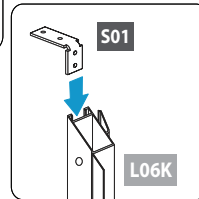
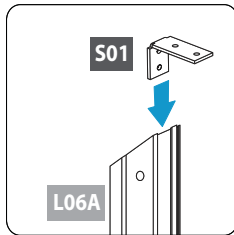
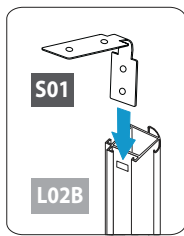
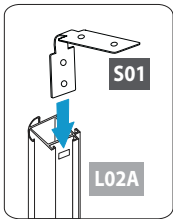

**3.1B** Line up lower hole on connector S01 with hole in each profile and secure with S02 screws.

**NOTE:** ALL VIEWS ARE FROM INSIDE.

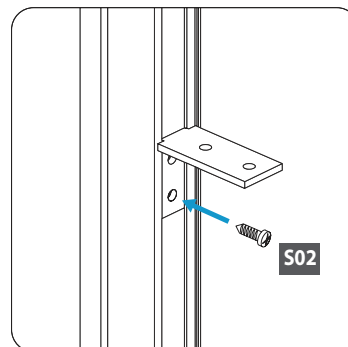
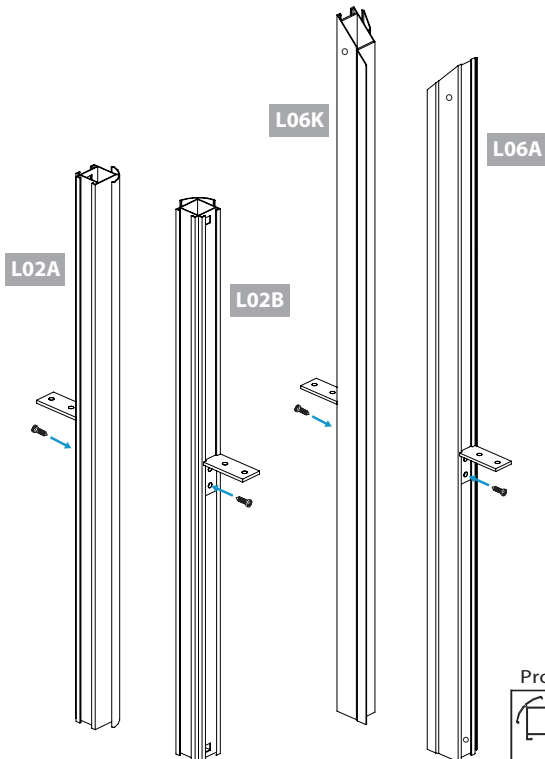

Profile	QTY	Profile	QTY	Connector	QTY
#L02A	1	#L06A	1	#S01	4
#L02B	1	#L06K	1	#S02	4

**3.2A** Slide profiles L06J into L06A and L06K using connectors S28. S28 connectors do not snap into place.

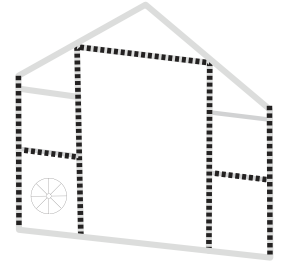
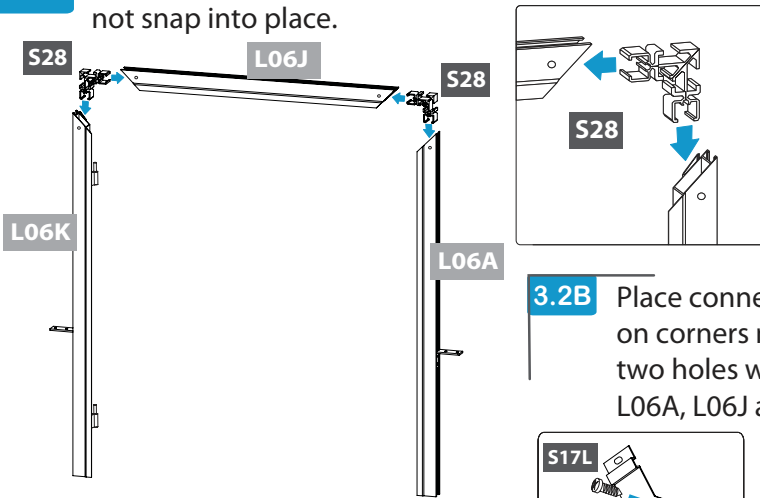

**3.2B** Place connectors S17L and S17R on corners matching up bottom two holes with holes in profiles L06A, L06J and L06K as shown.

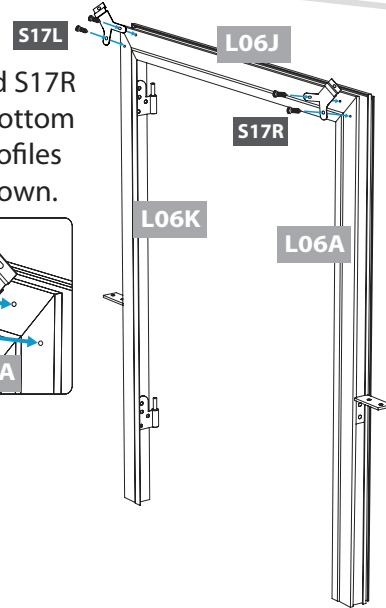
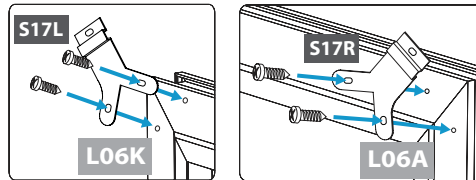

**3.2C** Secure each connector with S02 screws.

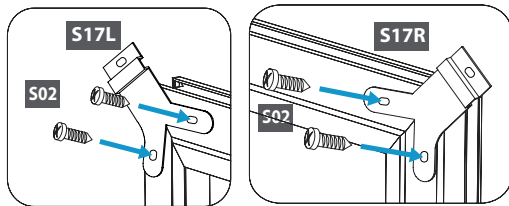

Profile	QTY	Connector	QTY	Connector	QTY	Connector	QTY
#L06J	1	#S28	2	#S17L	1	#S17R	1
				#S02	2	#S02	2

**3.3A** Attach profiles L02B and L06K to profile L04A. Slide long sides of connectors S01 into channels of profile L04A, lining up last hole in S01 with holes in profile L04A. Attach profiles L06A and L02A to profile L04A. Slides long side of connectors S01 into channels of profiles L04A, lining up last hole of S01 with holes in L04A.

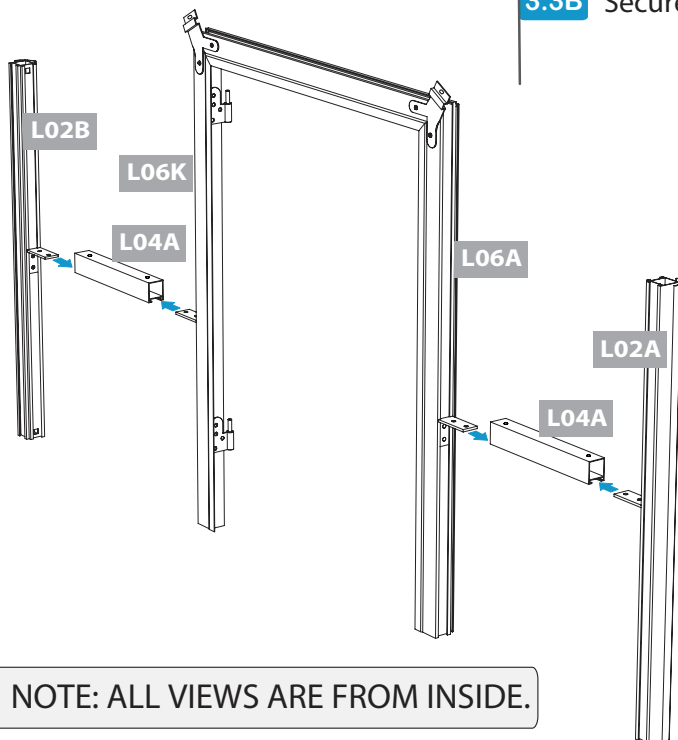

**3.3B** Secure with S02 screws.

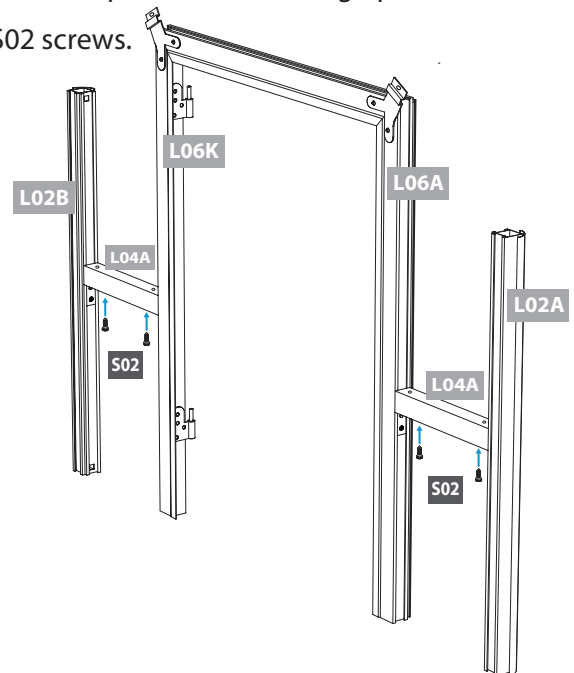

**NOTE: ALL VIEWS ARE FROM INSIDE.**

Profile	QTY	Screw	QTY
#L04A	2	#S02	4

**3.4A** Slide profiles L02K and L02L into connectors S09, S18 and S10 until they click into place.

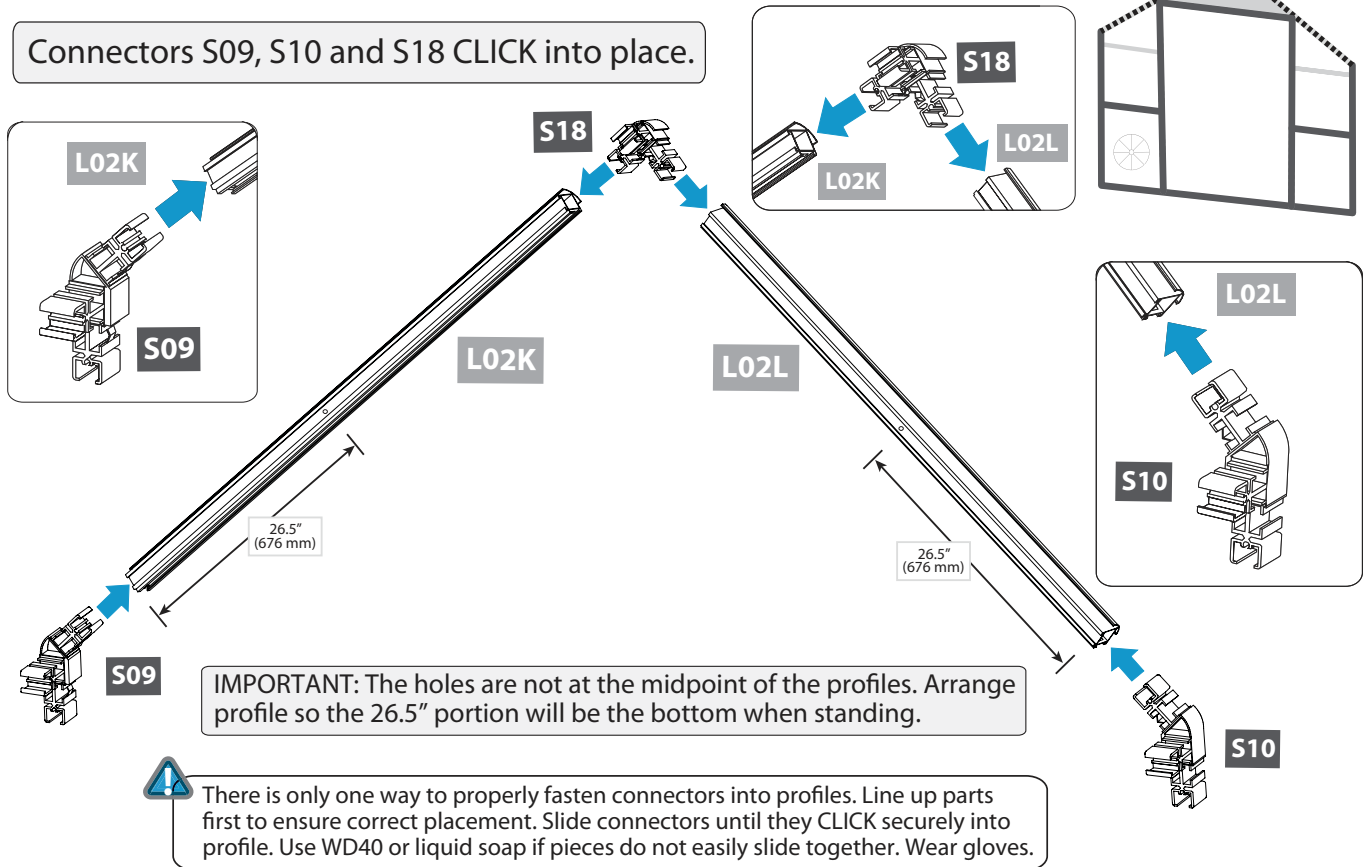

Profile	QTY	Connector	QTY	Connector	QTY	Connector	QTY
#L02K	1	#S09	1	#S10	1	#S18	1
#L02L	1						

**3.4B** Remove protective plastic from both sides of panel Y20. Place side to face toward the sun facing down. Fit panel into V-channel on profile L06J.

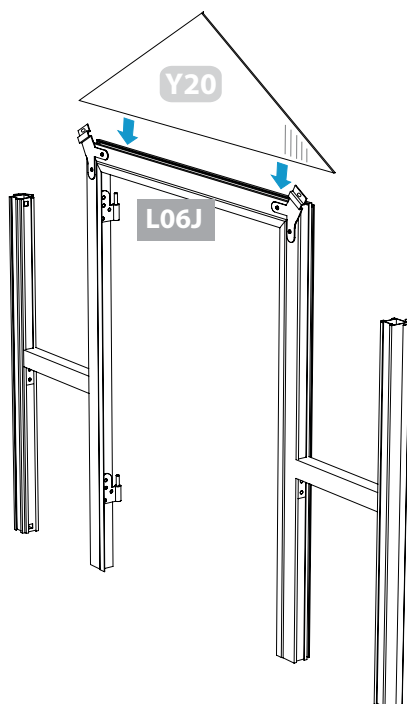

**!** Remove protective plastic from EACH side of poly carbonate panels before installing. Dispose of plastic properly. Install with side labeled "Face this side towards the sun" FACING DOWN.

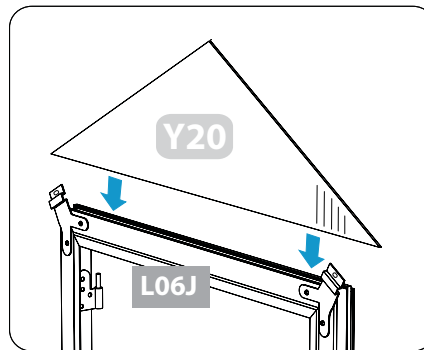

**NOTE:** ALL VIEWS ARE FROM INSIDE.

Panel	QTY
#Y20	1

**3.5A** Slide connectors S09 and S10 half way into profiles L02A and L02B. Continue sliding together making sure panel Y20 fits into V-channels of profiles L02L and L02K. Connectors S17L and S17R rest in channels of L02L and L02K. Connectors S09 and S10 click securely into profiles.

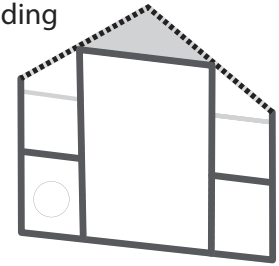
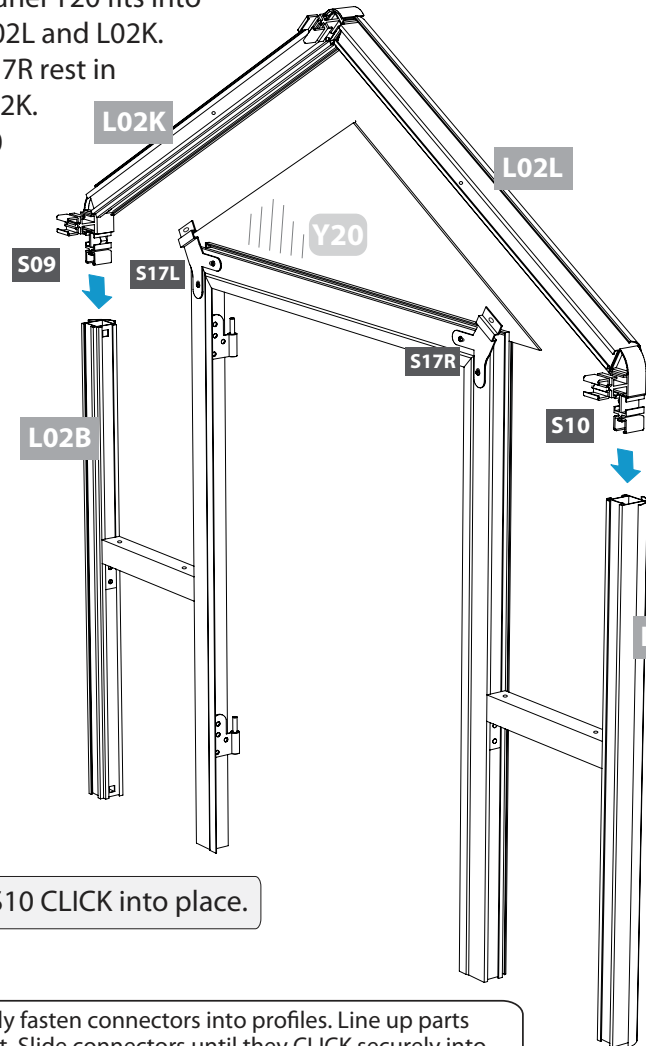
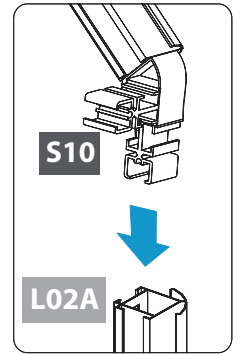
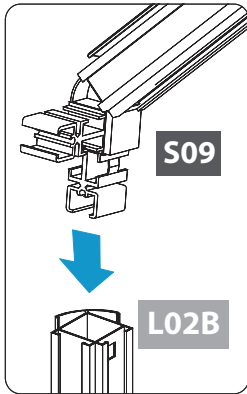

Connectors S09 and S10 CLICK into place.

**!** There is only one way to properly fasten connectors into profiles. Line up parts first to ensure correct placement. Slide connectors until they CLICK securely into profile. Use WD40 or liquid soap if pieces do not easily slide together. Wear gloves.

**3.5B** Loosen the four screws in connectors S17L and S17R enough to adjust door frame profiles L06A, L06J and L06K and align with gable profiles L02L and L02K. Secure connectors S17L and S17R to profiles L02K and L02L with two S02 screws and tighten four screws connecting profiles L06A and L06K.

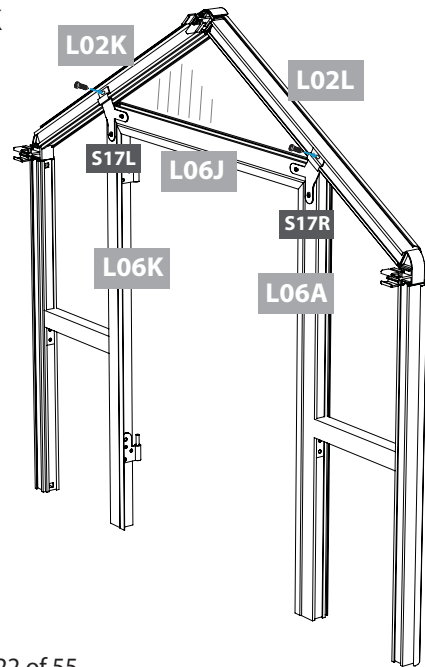
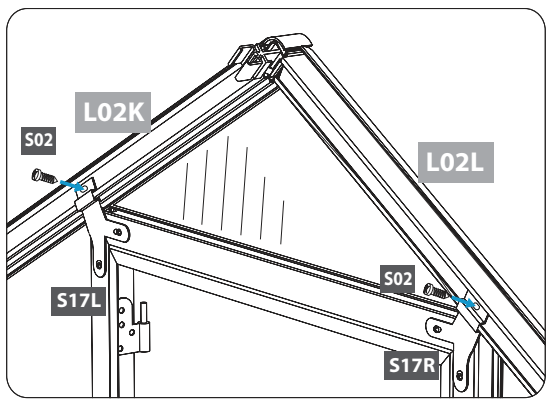

NOTE: ALL VIEWS ARE FROM INSIDE.

Screw	QTY
 #S02	2



**3.6A** Remove protective plastic from both sides of panels Y5, Y6 and Y19. Place side to face toward the sun facing the down. Fit panels Y19 into top channels of L05C.

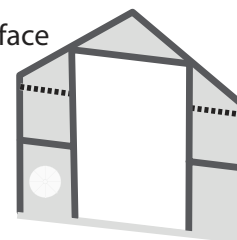

**IMPORTANT:** Make sure to assemble a right and left side.

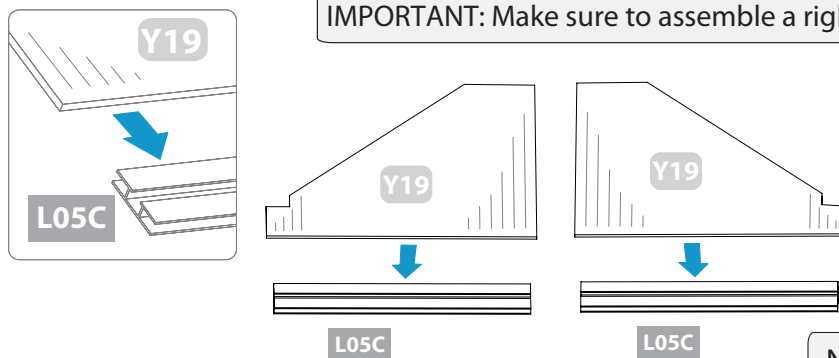

**NOTE:** ALL VIEWS ARE FROM INSIDE.

**!** Remove protective plastic from EACH side of poly carbonate panels before installing. Dispose of plastic properly. Install with side labeled "Face this side towards the sun" FACING DOWN.

**3.6B** Slide Y19 panels into V-channels on profiles L02A, L02B, L06A and L06K. Note Y20 panel sits next to panel Y19.

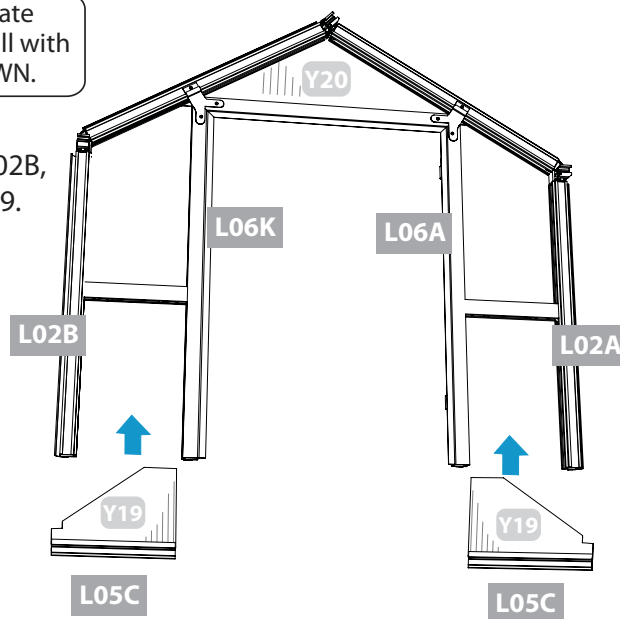
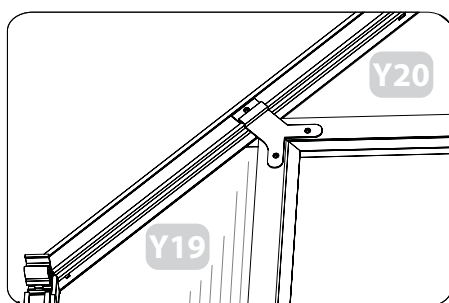

**3.6C** Slide Y5 and Y6 panels into V-channels on profiles L02A, L02B, L06A and L06B. Fit inside channels on L05C profiles.

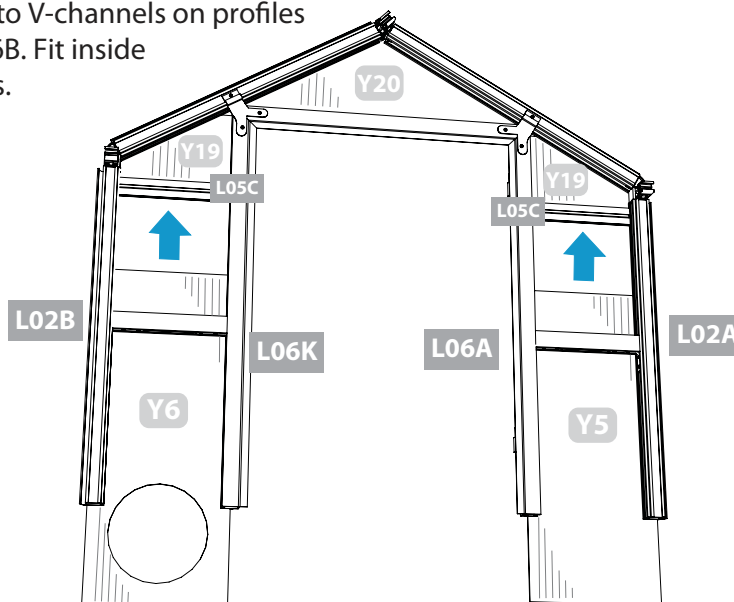

Panel	QTY	Profile	QTY	Panel	QTY	Panel	QTY
	#L05C	2		#Y6	1		1
			2				

**3.7A** Line up connector S08C with holes on profiles L01K as shown.

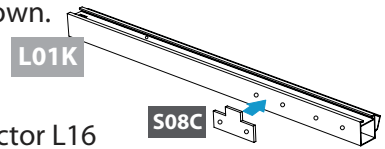

**3.7B** Secure with two S02 screws.

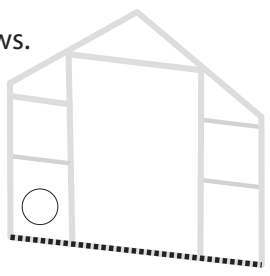
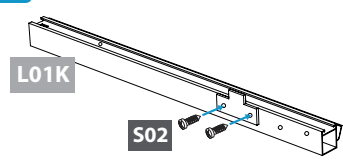

**3.7C** Slide connector L16 inside profiles L01K and L01L.

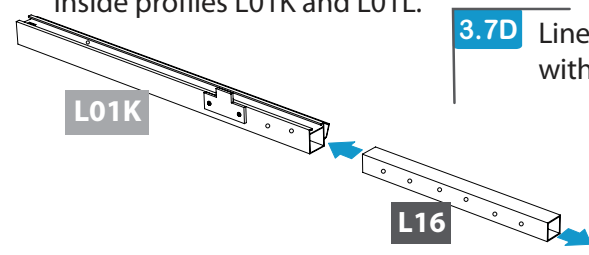

**3.7D** Line up outside holes on connector L16 with holes on profiles L01L and L01K. Secure with four S02 screws.

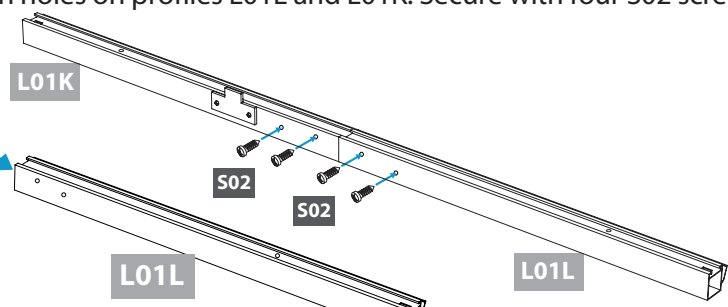

**3.8A** Slide short side of connectors S01 into channels of profiles L01K and L01L. Line up last hole on connector with holes on profile.

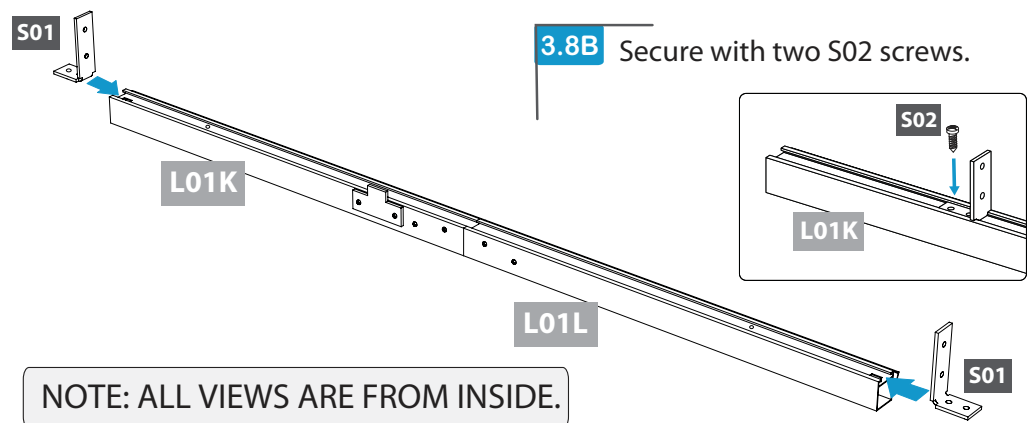

**3.8B** Secure with two S02 screws.

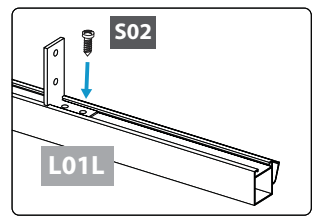
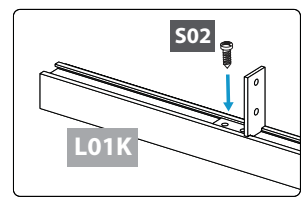

NOTE: ALL VIEWS ARE FROM INSIDE.

Profile	QTY	Connector	QTY	Connector	QTY	Connector	QTY
#L01K	1	#S02	2	#L16	1	#S01	2
#L01L	1	#S08C	1	#S02	4	#S02	2

**3.8C** Slide connectors S04 into profile L01K and connector S05 into profile L01L until they securely click into place.

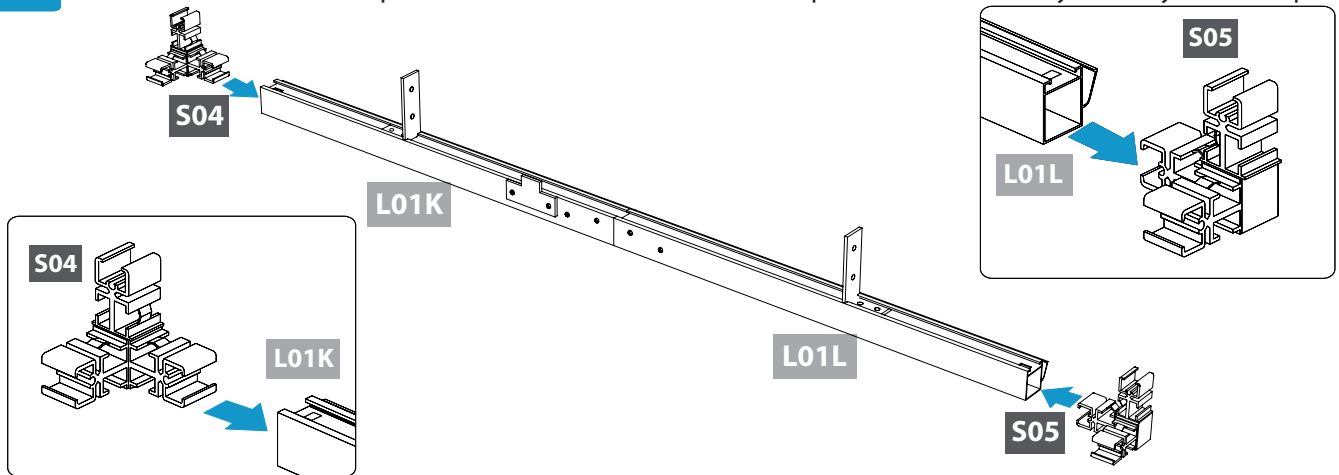

Connectors S04 and S05 CLICK into place.

Connector	QTY	Connector	QTY
#S04	1	#S05	1

**3.9A**

As you slide bottom profiles L01L and L01K half way into place, carefully line up S01 connectors with channels on profiles L06K and L06A and S04 and S05 connectors with profiles L02B and L02A. Continue sliding, making sure panels Y6 and Y5 fit into V-channels. Snap connectors S04 and S05 securely into profiles.

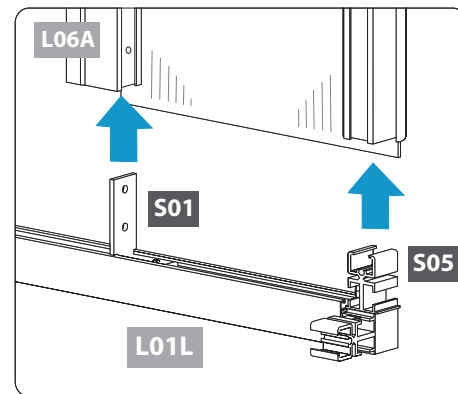
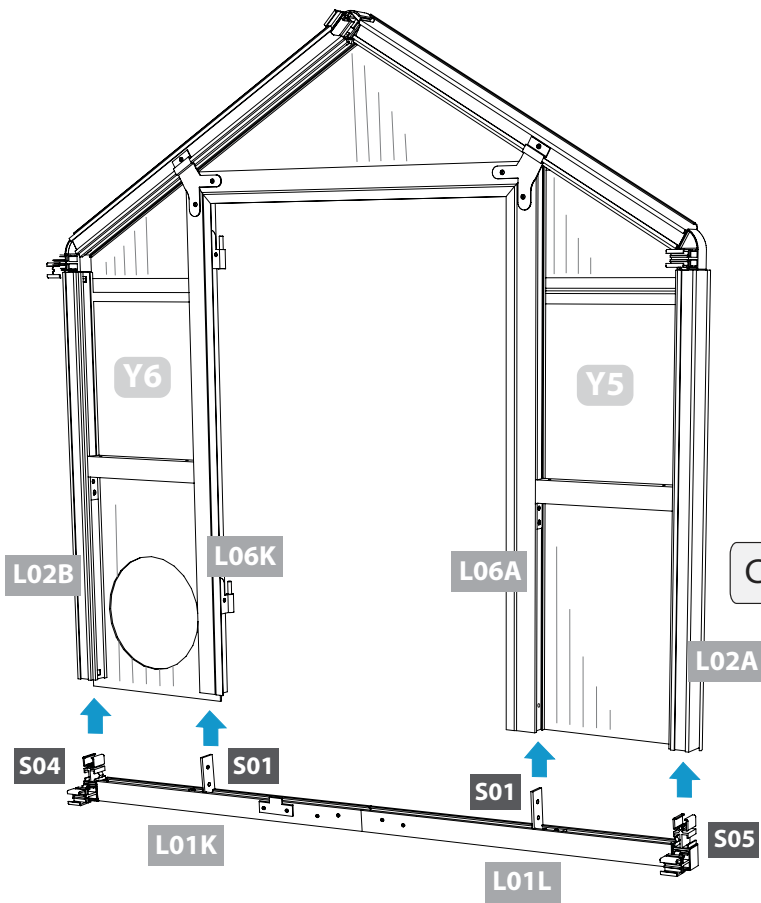
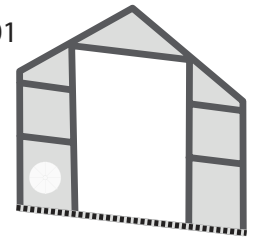

Connectors S04 and S05 CLICK into place.

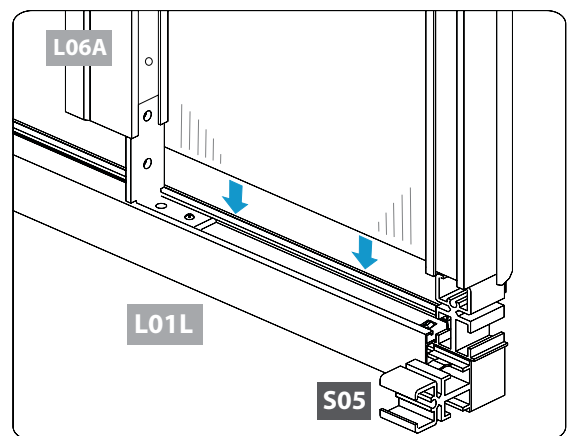

There is only one way to properly fasten connectors into profiles. Line up parts first to ensure correct placement. Slide connectors until they CLICK securely into profile. Use WD40 or liquid soap if pieces do not easily slide together. Wear gloves.

**3.9B**

Secure S01 connector to profiles L06A and L06K with S02 screws.

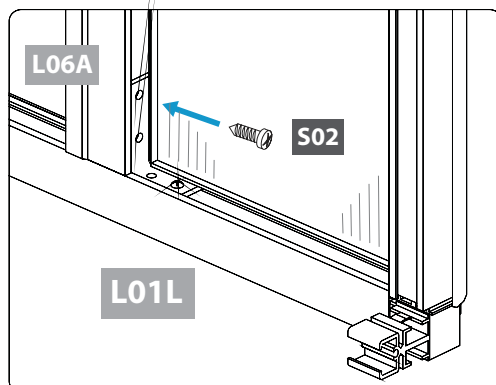

NOTE: ALL VIEWS ARE FROM INSIDE.

Screw	QTY
 #S02	2

**3.10A**

Insert long side of cable connector S06 at an angle into profile channel L02B with HOOK FACING UP. Slide connector to other side of channel. Use hex key to securely tighten and hold in place.

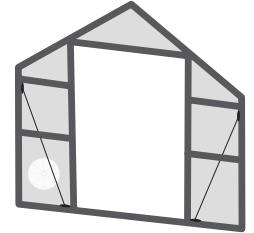
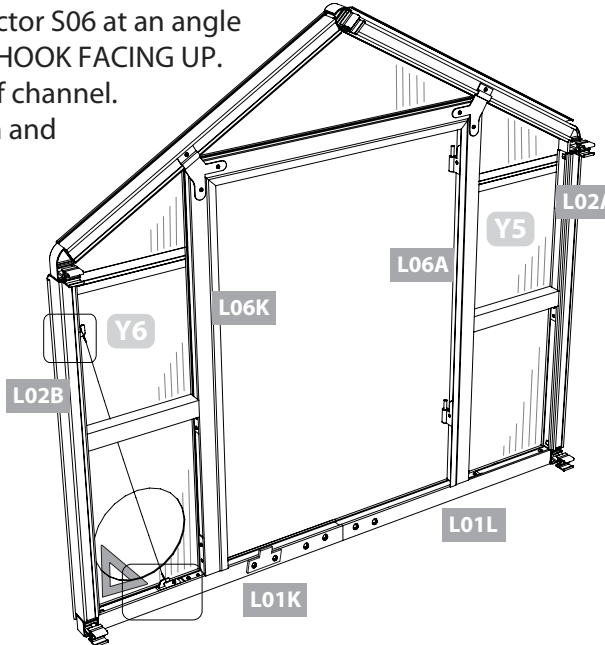
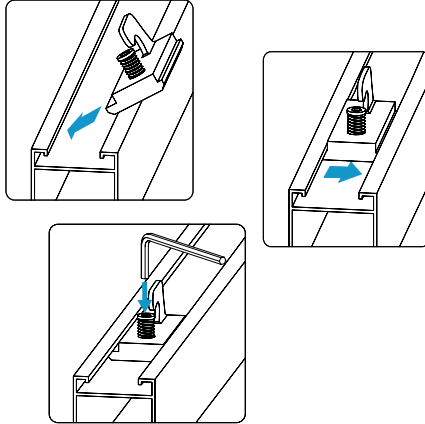

**3.10B**

Attach one side of short cable S16 to hook on S06 and lace under profile L04A. Attach other side of cable to a second S06 cable connector and with hook facing center, insert into profile channel L01K. Push the S06 connector towards center until profile corners are square and cable is tight. Use hex key to securely tighten and hold in place.

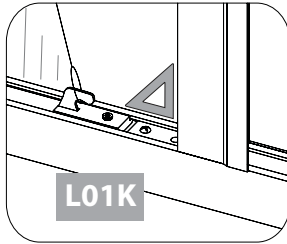
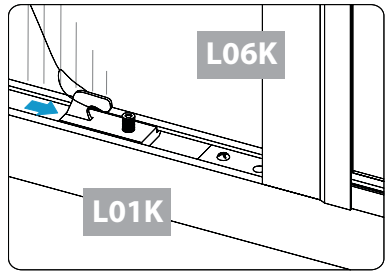

**IMPORTANT:** Make sure all corners are squared at 90 degrees.

**3.11**

Repeat step 3.10 inserting cable connectors S06 into profiles L02A and L01L. Cable rests next to panel Y5, under profile L04A. Slide connector until profile corners are square and cable is tight. Use hex key to securely tighten second connector and hold in place.

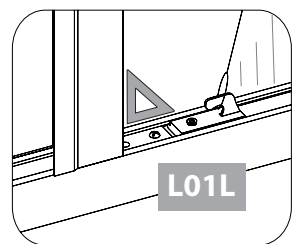
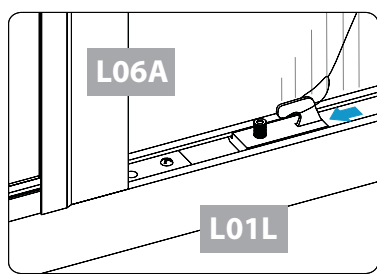

**IMPORTANT:** Make sure all corners are squared at 90 degrees.

**NOTE:** ALL VIEWS ARE FROM INSIDE.

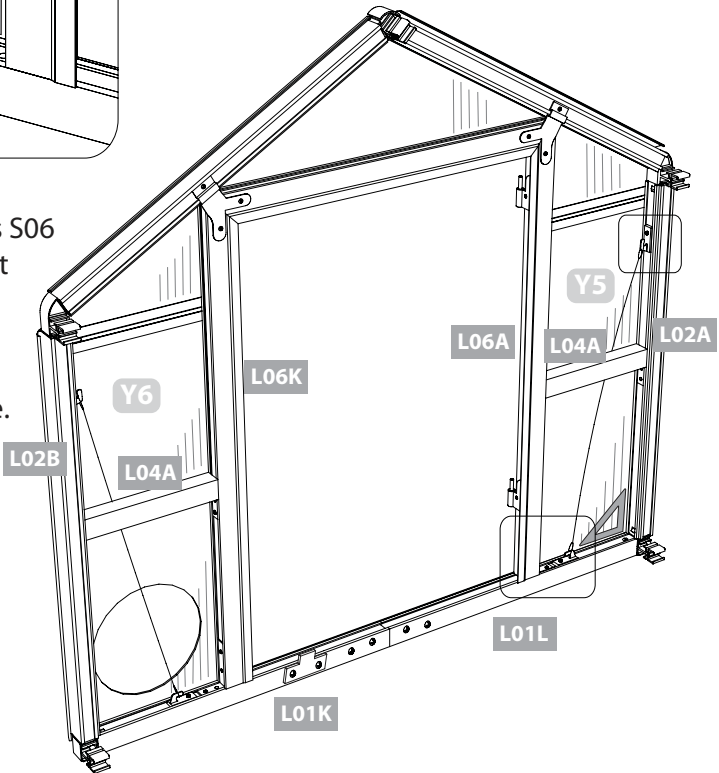

Hex Key	QTY	Cable Connector	QTY	Cable	QTY
	1		4		2
		#S06		#S16	

# Assemble Sides

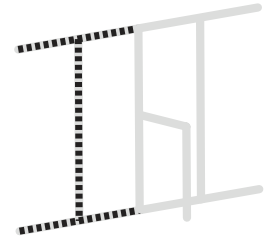

 Place all the parts for the sides on a level surface. Make sure the pieces are in the correct positions before assembling. Carefully follow the order of assembly to ensure an easy installation. Wear proper safety gear including work shoes, gloves and goggles.



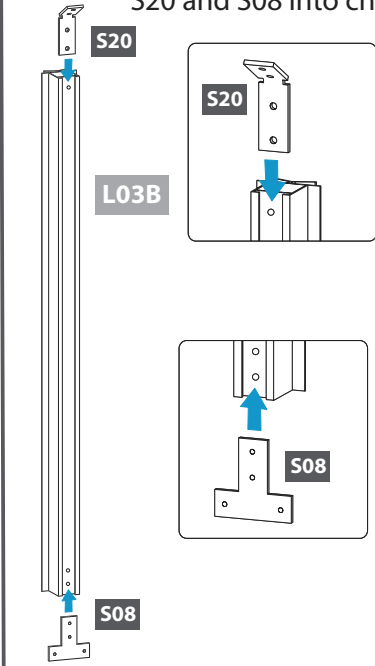

 You are assembling both sides in the following steps. Both sides are identical until step 6.1

**4.1A** Line up the four profiles L03B so the holes are at the same position. Slide long side of connectors S20 and S08 into channel of profile, lining up holes as shown. Repeat for all four L03B profiles.

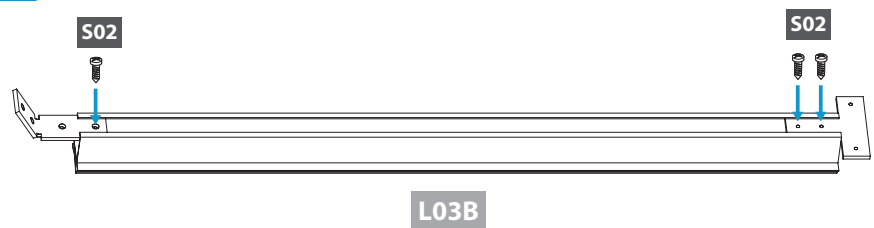

**4.1B** Secure with three S02 screws.



Profile	QTY	Connector	QTY	Connector	QTY
 #L03B	4	 #S02	4	 #S08	4
		 #S20	4	 #S02	8

**4.2A** Place L03B onto profiles L07A and L01C. Line up holes as shown.

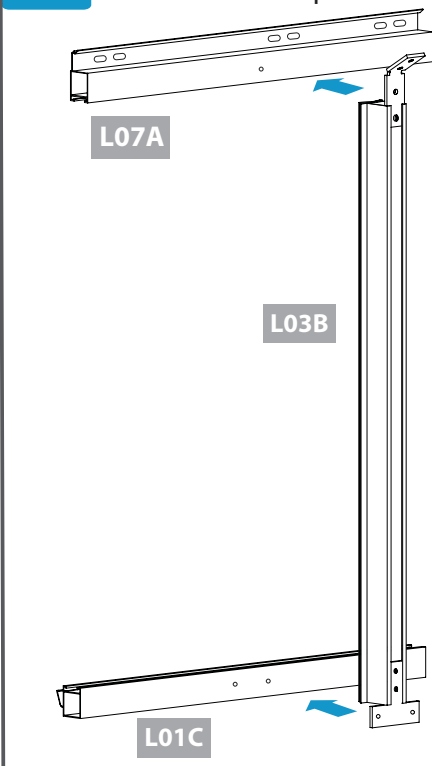

**4.2B** Secure with three S02 screws. Repeat to make two sets.

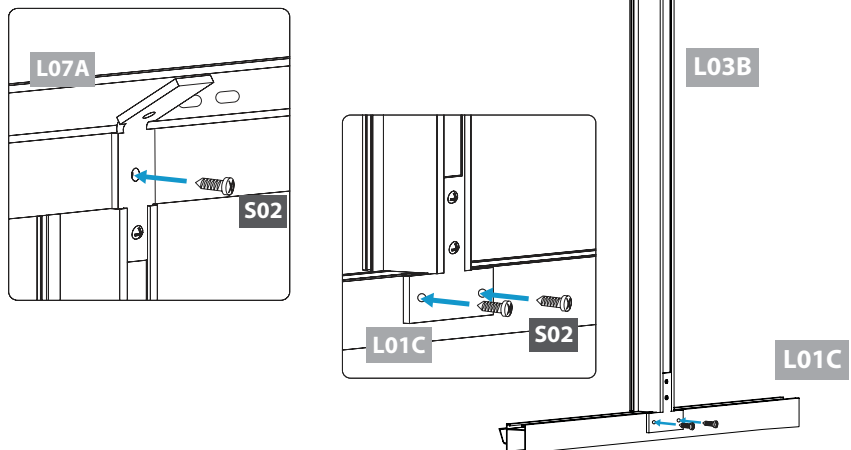

Profile	QTY	Profile	QTY	Screw	QTY
 #L01C	2	 #L07A	2	 #S02	6

**4.3A** Place L03B onto profiles L07B and L01C. Line up holes as shown.

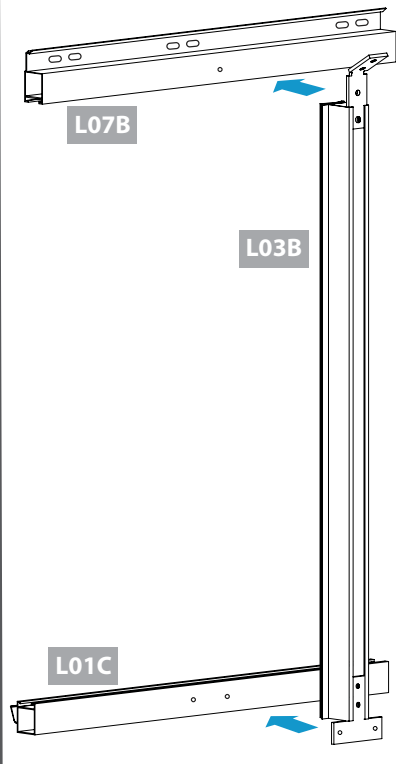

**4.3B** Secure with three S02 screws. Repeat to make two sets.

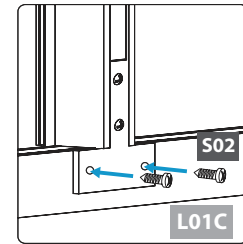
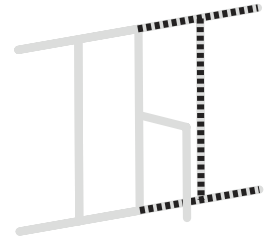
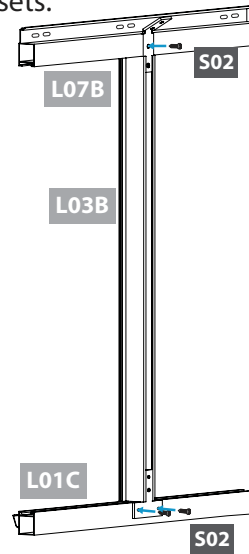
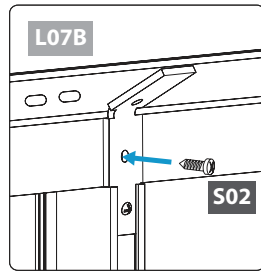

Profile	QTY	Profile	QTY	Screw	QTY
#L01C	2	#L07B	2	#S02	6

**4.4A** Lay out profiles L03A so the holes are at the same position. Slide short side of connectors S01 into channel of profile until the last hole in S01 lines up with the bottom hole on profile L03A.

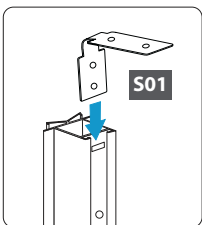

**! IMPORTANT:** The holes are not at the midpoint of the profile. Arrange profile so the 28" portion will be the bottom when standing.

**4.4B** Slide another connector S01 so it lines up with the middle hole on profile L03A.

**4.4C** Secure all pieces with S02 screws. Repeat to make two sets.

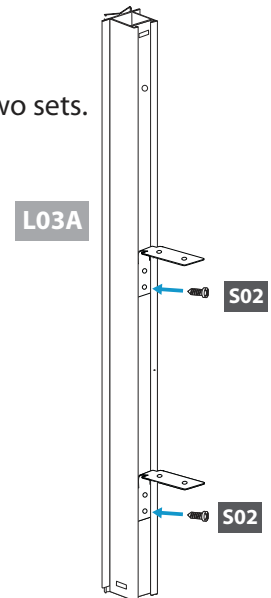
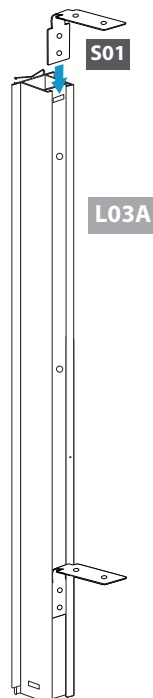
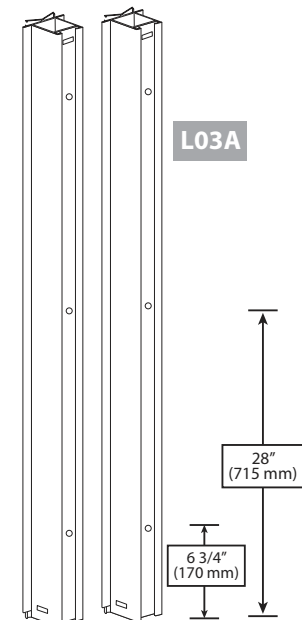

Profile	QTY	Connector	QTY
#L03A	2	#S01	4
		#S02	4

**4.5A** Lay out profiles L04D so the holes are at the same position. Slide short side of connector S01 into channel of profile, lining the last hole in S01 with the hole on profile L04D. Secure with S02 screw.

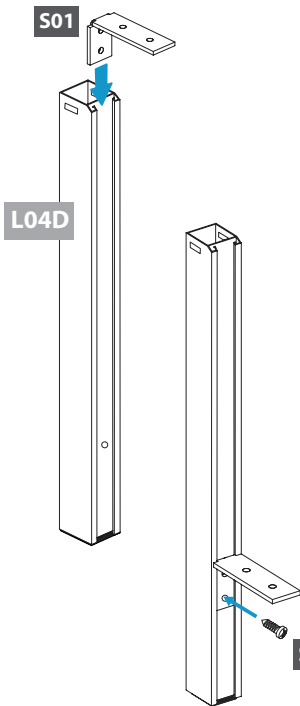

**4.5B** Slide connector S39 into profile L04D until it snaps into place. Repeat to make two sets.

Connector S39 CLICKS into place.

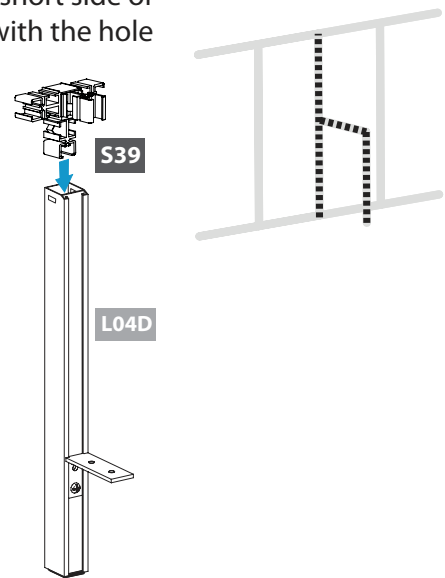
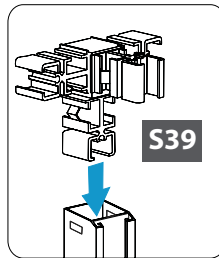

**!** There is only one way to properly fasten connectors into profiles. Line up parts first to ensure correct placement. Slide connectors until they CLICK securely into profile. Use WD40 or liquid soap if pieces do not easily slide together. Wear gloves.

Profile	QTY	Connector	QTY	Connector	QTY
#L04D	2	#S01	2	#S39	2
		#S02	2		

**4.6** Slide connector S03 into profile L04B until it clicks into place.

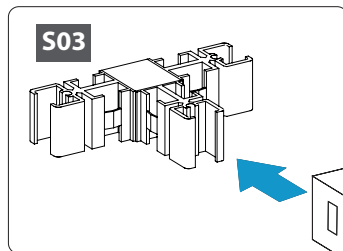
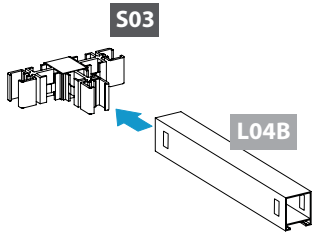

Connector S03 CLICKS into place.

Profile	QTY	Connector	QTY
#L04B	2	#S03	2

**4.7A** Attach profiles L04B and L04C to profile L03A by sliding the long sides of connectors S01 into the channels. The last hole of connector S01 lines up with the holes in the profiles.

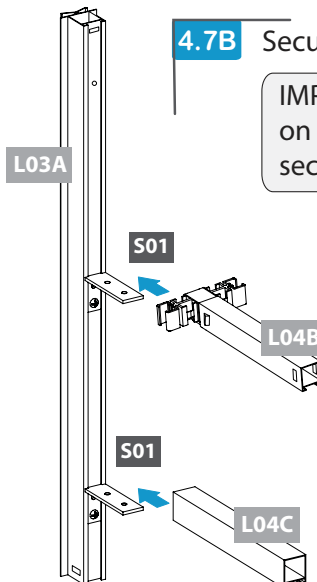

**4.7B** Secure with two S02 screws. Repeat to make two sets.

**IMPORTANT:** Connector S03 rests on top of connector S01. S02 screw secures S03 to profile L04B.

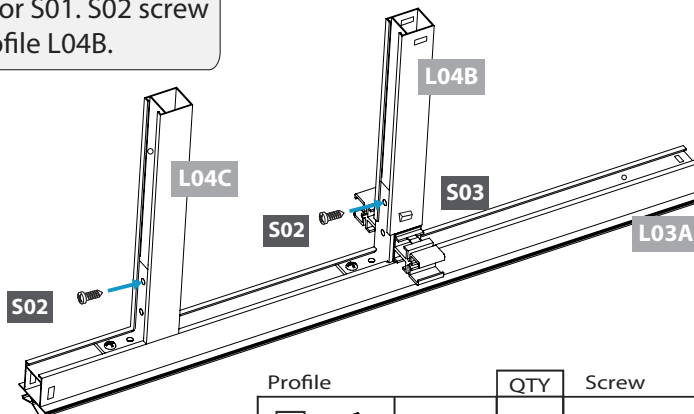

Profile	QTY	Screw	QTY
#L04C	2	#S02	4

**4.8A** Connect profile L04D by sliding connector S39 into profile L04B until it snaps in place. Slide connector S01 into channel of L04C.

Connectors S39 CLICKS into place.

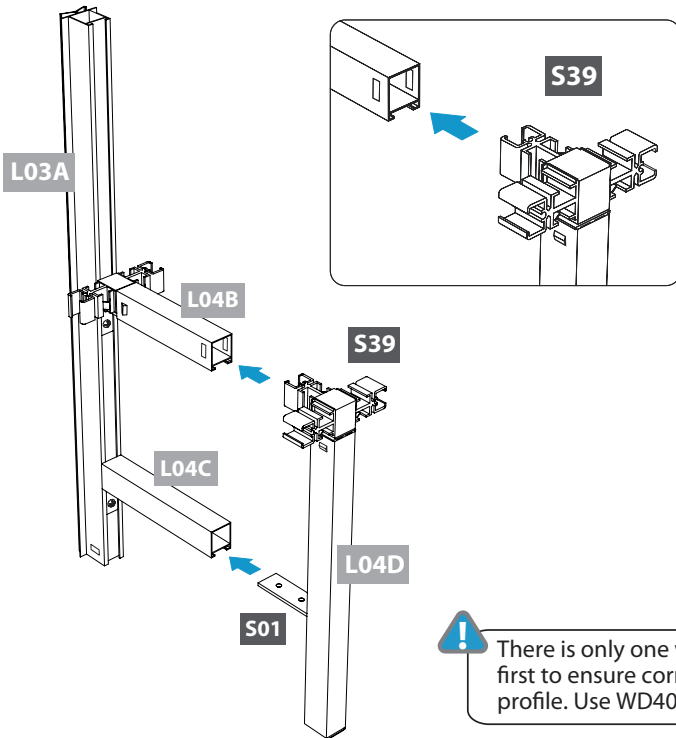

**4.8B** Secure with S02 screw. Repeat to make two sets.

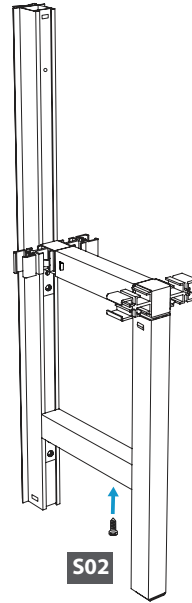



Screw		QTY
	#S02	2

**!** There is only one way to properly fasten connectors into profiles. Line up parts first to ensure correct placement. Slide connectors until they CLICK securely into profile. Use WD40 or liquid soap if pieces do not easily slide together. Wear gloves.

**4.9** Slide connectors S19 and S03 into profile L03A. Snap securely into place. Repeat to make two sets.

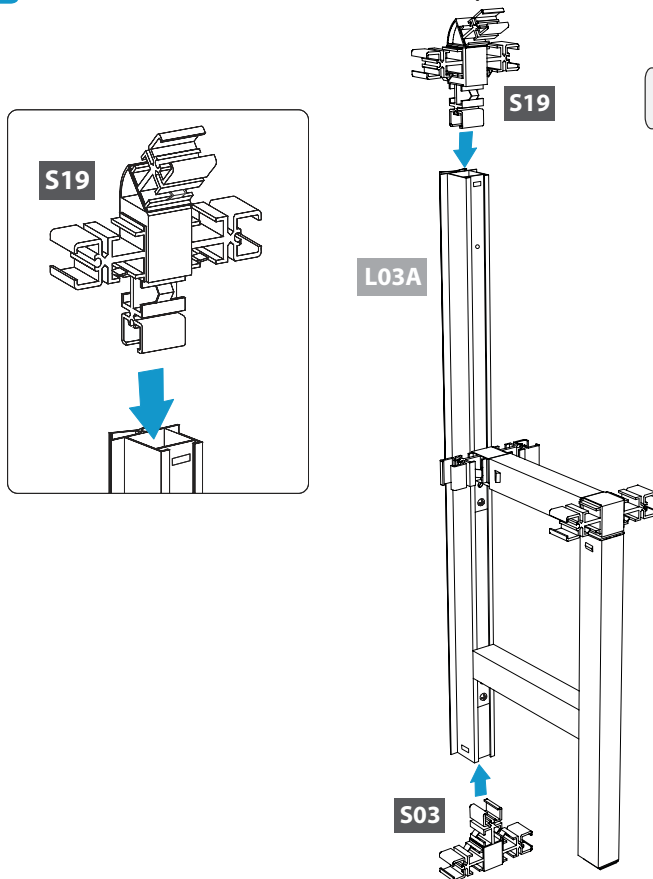
Connectors S03 and S19 CLICK into place.

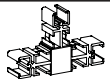

Connector	QTY	Connector	QTY		
	#S03	2		#S19	2



**4.10** Slide sections together as shown. Repeat to make two sets.

**!** There is only one way to properly fasten connectors into profiles. Line up parts first to ensure correct placement. Slide connectors until they **CLICK** securely into profile. Use WD40 or liquid soap if pieces do not easily slide together. Wear gloves.

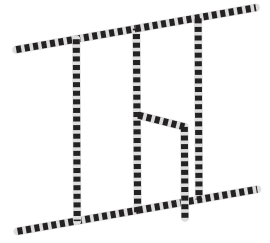

Connectors S03 and S19 **CLICK** into place.

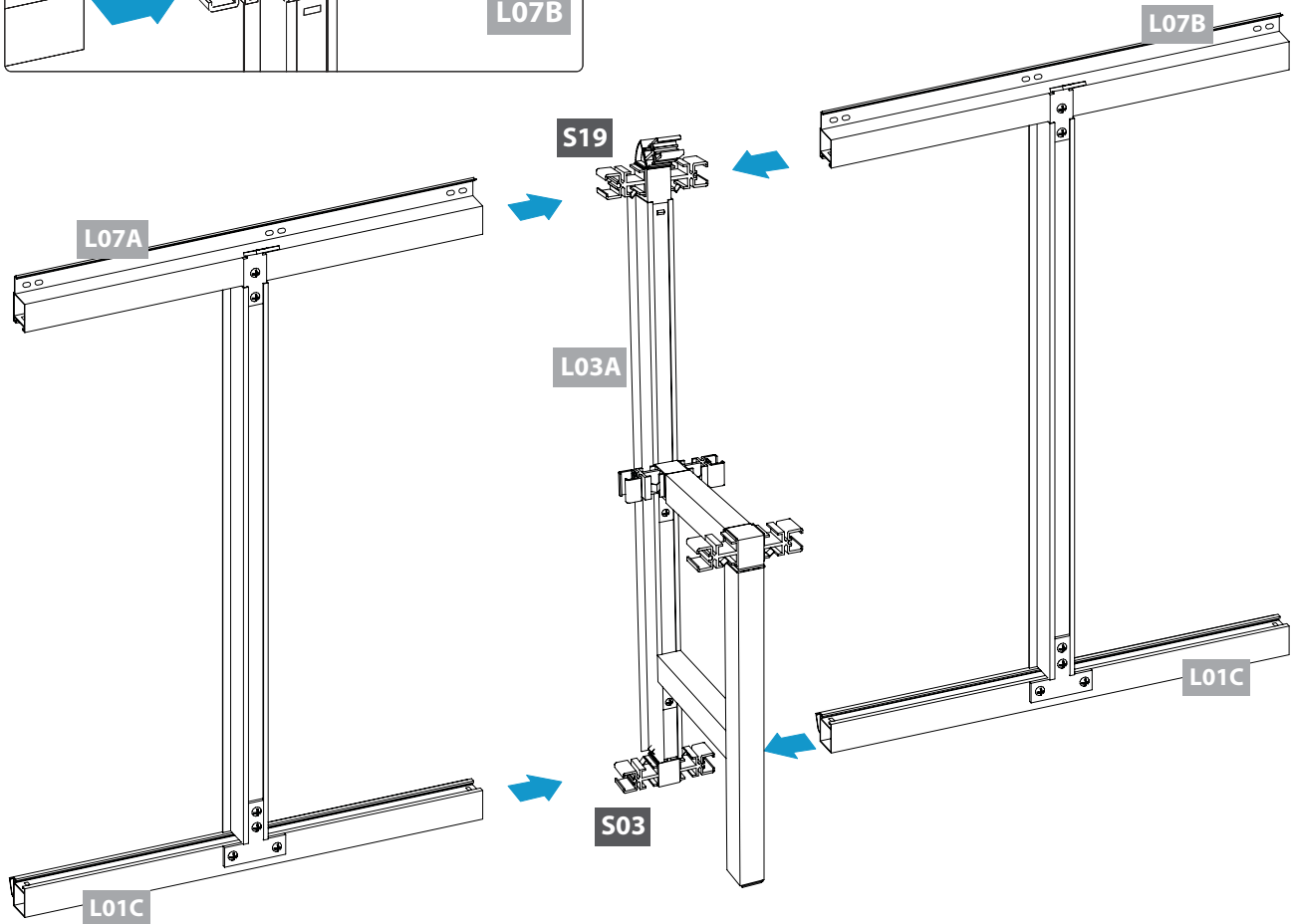
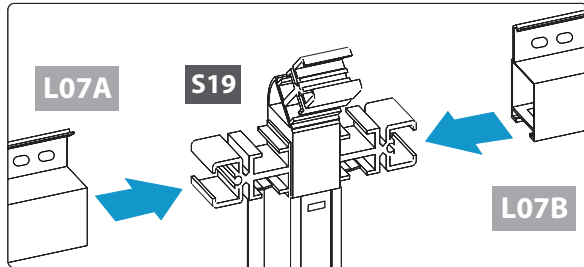

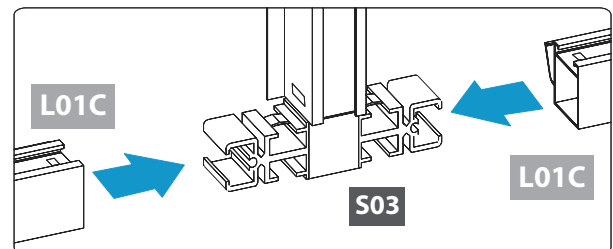

NOTE: ALL VIEWS ARE FROM INSIDE.

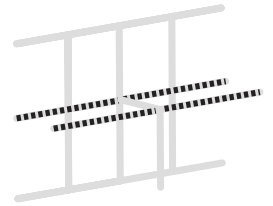

**!** NOTE: The two sides are identical. When you connect them to the back, there will be a right and left side. Stand these up.

# Prepare Shelves



 Place all the parts for the shelves on a level surface. Make sure the pieces are in the correct positions before assembling. Carefully follow the order of assembly to ensure an easy installation. Wear proper safety gear including work shoes, gloves and goggles.



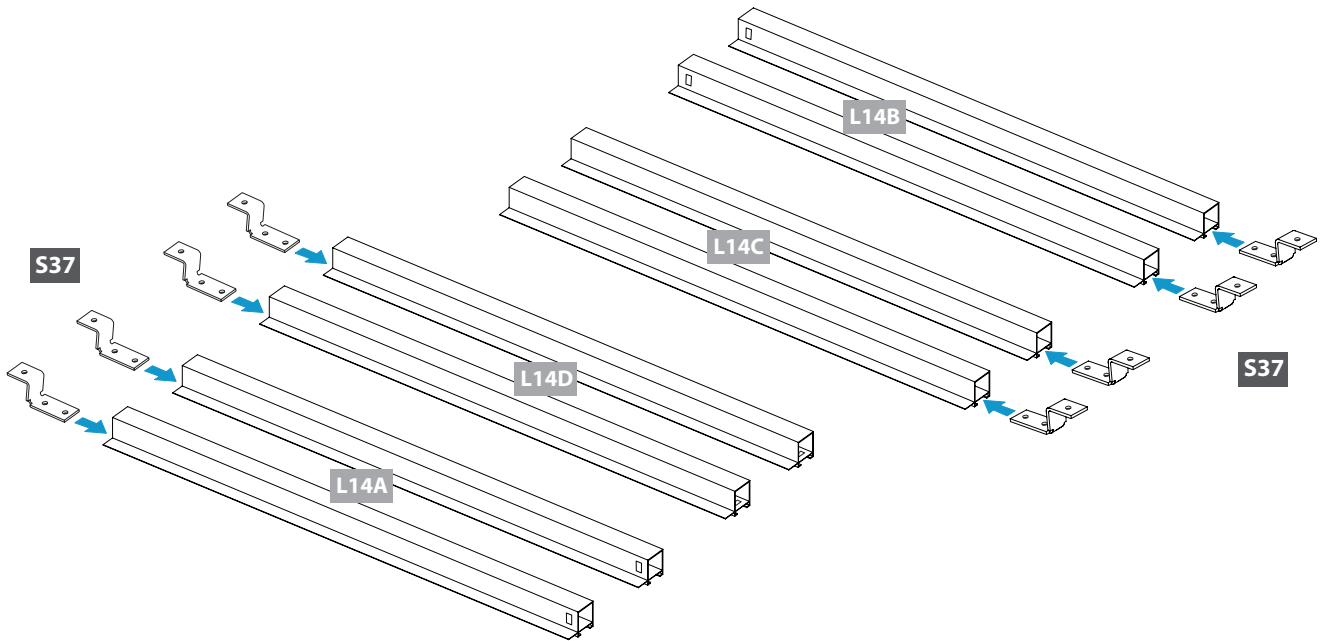



**5.1A** Line up the shelf profiles so the holes are at the same position. Slide long side of connector S37 into channel of each profile, lining up the last hole on the connector with the hole in the channel.

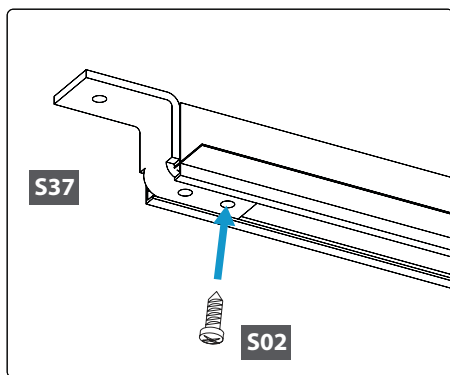

**IMPORTANT:** The shelf profiles have rectangular holes in the channel or side of one end. Slide connector S37 into other side, lining up last hole in connector with hole in the channel.

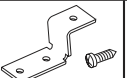
**5.1B** Secure with S02 screw.

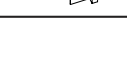

Profile	QTY	Profile	QTY	Connector	QTY
 #L14A	2	 #L14C	2	 #S37	8
 #L14B	2	 #L14D	2	 #S02	8

# Connect Sides to Back

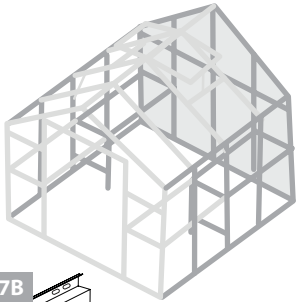

With the outside facing a wall, carefully stand back up and lean against the wall. Stand each side up and place next to the back. Both sides are identical until the shelf profiles are connected. Make certain that positions of profiles L07A and L07B match the diagrams before connecting.

## 6.1A

Set up one side facing inside with L07B next to the back. Slide shelf profile L14B into connector S03 until it clicks into place. Slide shelf profile L14D into connector S39 until it clicks into place.

Connectors S03 and S39 CLICK into place.

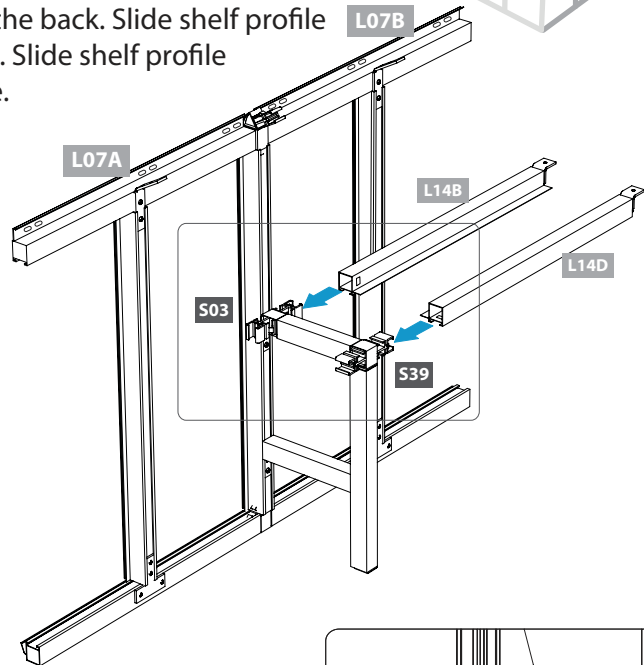
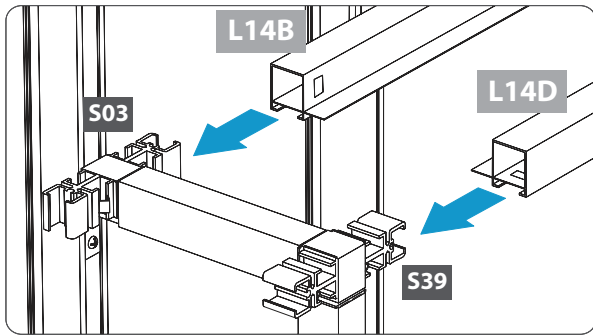

## 6.1B

Carefully slide left side into back, lining up connectors with profiles. Move side so connectors S09 and S04 are half way into profiles L07B and L01C. Connectors S37 rest on top of profile L04F. Push side in until connectors click into place.

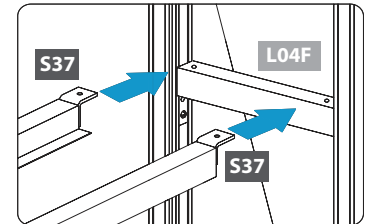
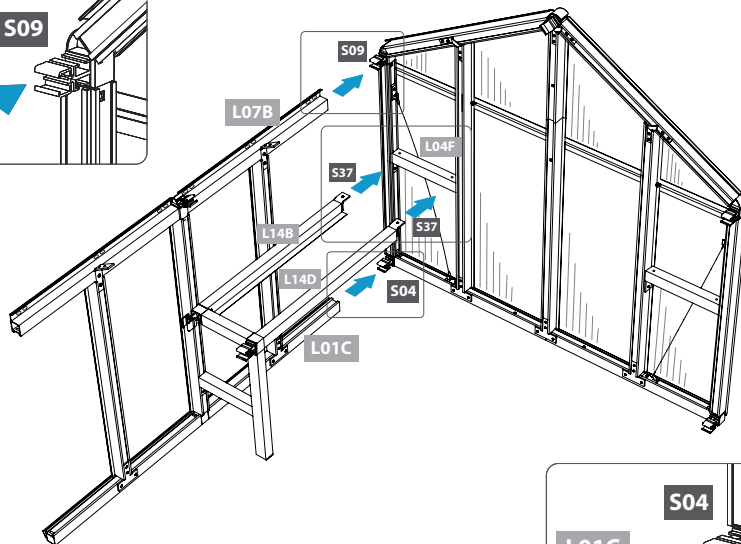
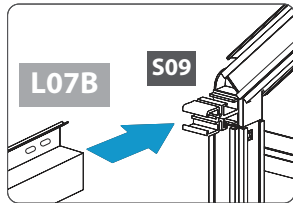

Secure connectors S37 to profile L04F with two S02 screws.

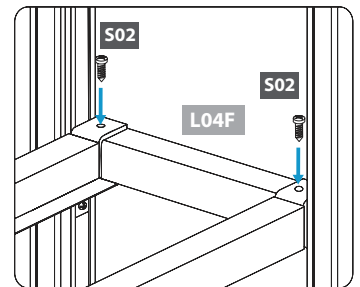

IEWS FROM INSIDE.

Connectors S04 and S09 CLICK into place.

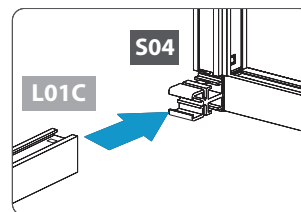

There is only one way to properly fasten connectors into profiles. Line up parts first to ensure correct placement. Slide connectors until they CLICK securely into profile. Use WD40 or liquid soap if pieces do not easily slide together. Wear gloves.

Screw	QTY
 #S02	2

**6.2A** Set up the other side facing inside with profile L07A next to back. Slide shelf profile L14A into connector S03 until it clicks into place. Slide shelf profile L14C into connector S39 until it clicks into place.

Connectors S03 and S39 CLICK into place.

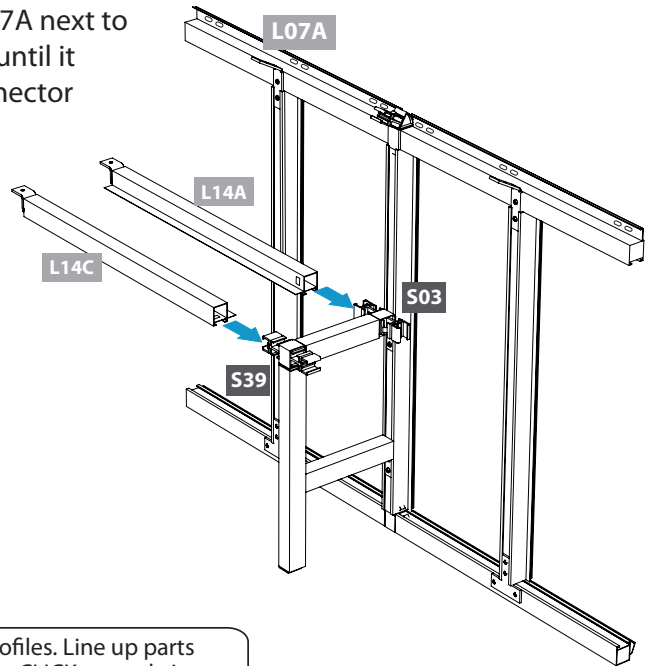
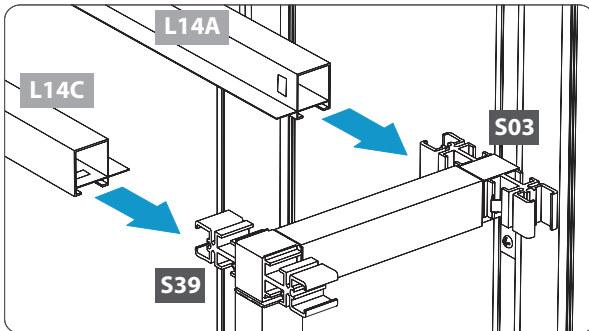

**!** There is only one way to properly fasten connectors into profiles. Line up parts first to ensure correct placement. Slide connectors until they CLICK securely into profile. Use WD40 or liquid soap if pieces do not easily slide together. Wear gloves.

**6.2B** Carefully slide right side into back, lining connectors up with profiles. Move side so connectors S10 and S05 are half way into profiles L07A and L01C. Connectors S37 rest on top of profile L04F. Push side in until connectors click into place.

Connector S10 CLICKS into place.

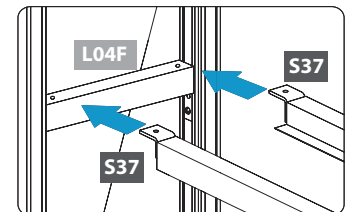
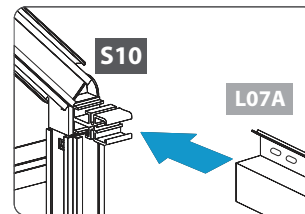
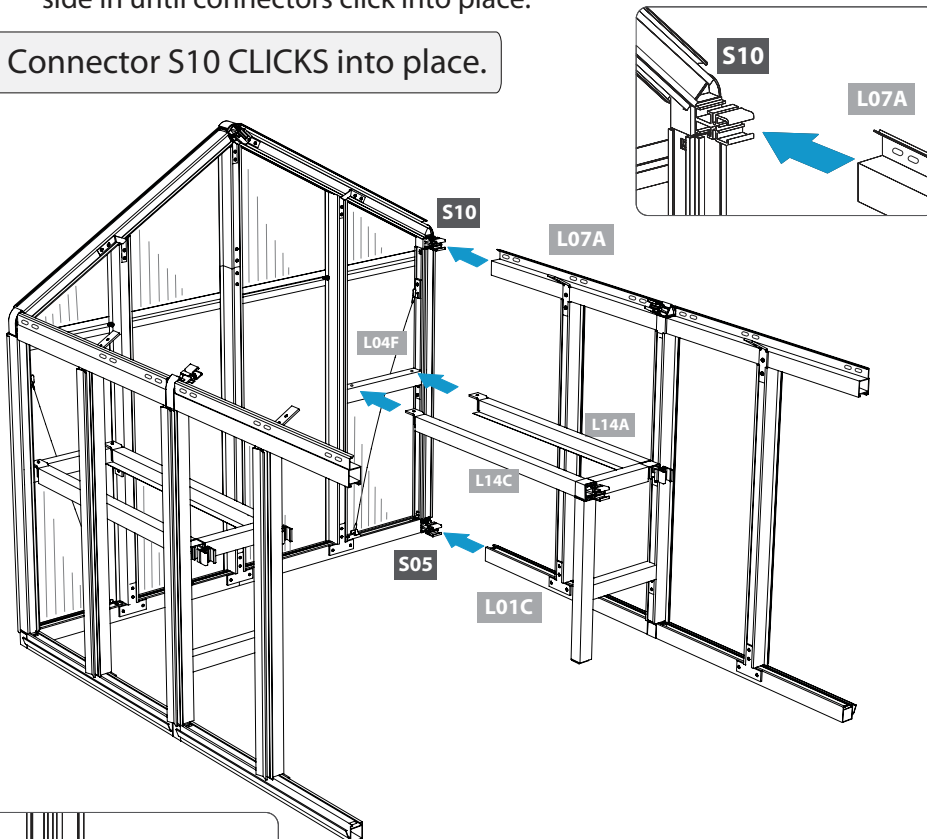

Secure connectors S37 to profile L04F with S02 screws.

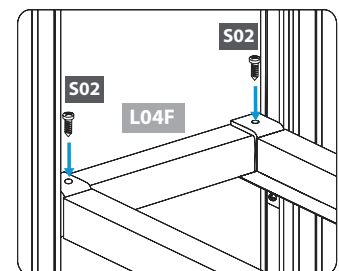

IEWS FROM INSIDE.

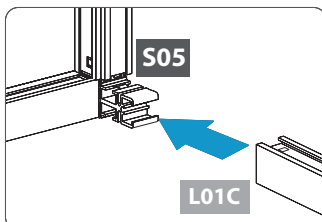

Connector S05 CLICKS into place.

Screw		QTY
	#S02	2

# Connect Sides to Front



Keep the structure as is, with the back against the wall until you finish this step. This will make it easier to keep the angles square.

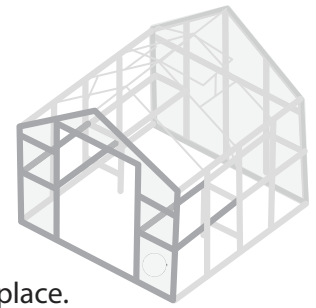

7.1

Slide shelf profile L14A into connector S03 on the left side until it clicks into place.  
Slide shelf profile L14B into connector S03 on the right side until it clicks into place.

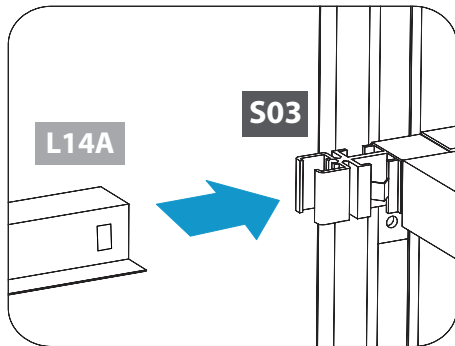

Connectors S03 CLICK into place.

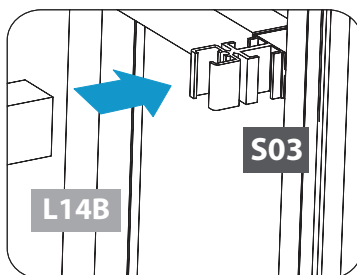
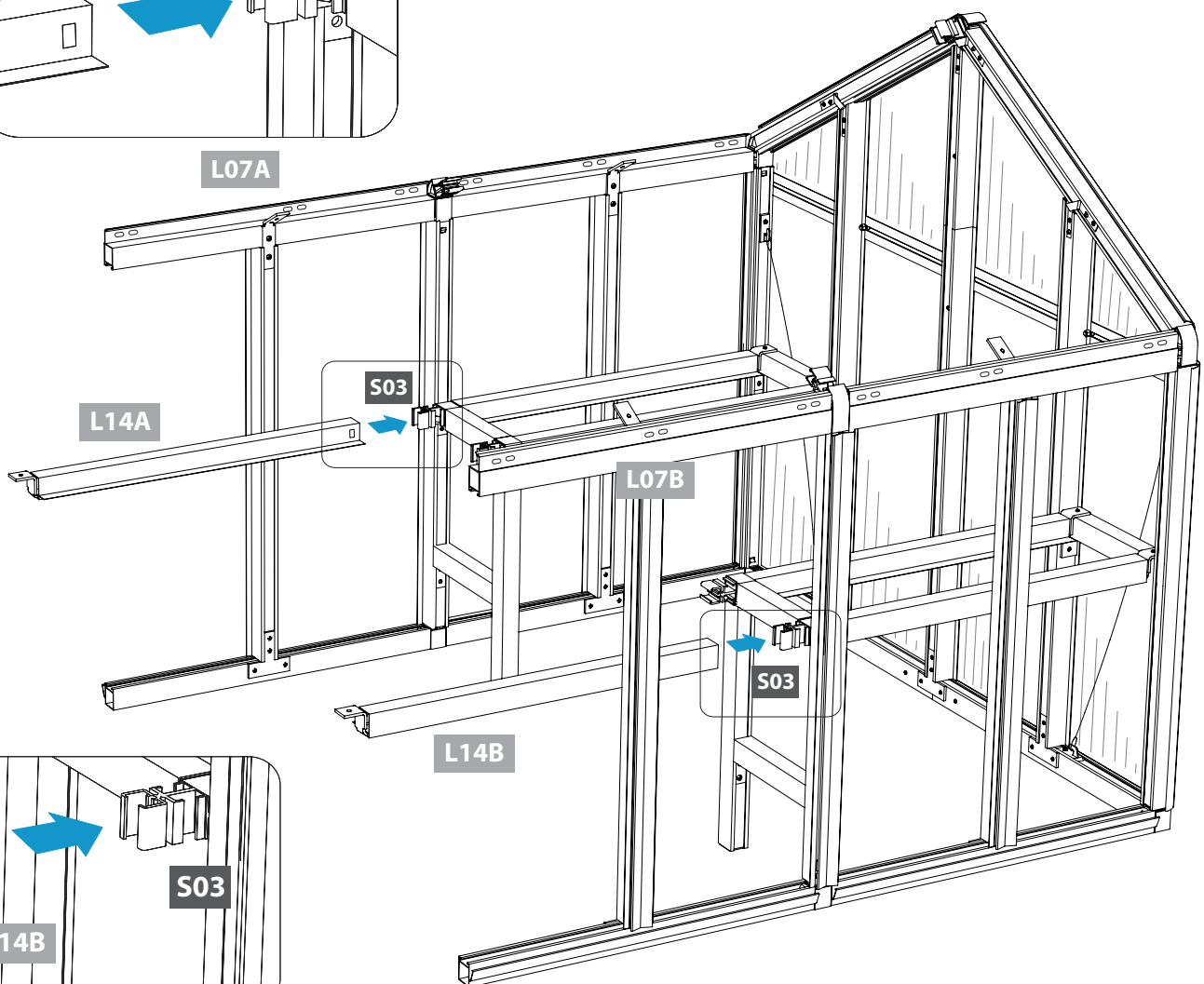

Connectors S03 CLICK into place.



There is only one way to properly fasten connectors into profiles. Line up parts first to ensure correct placement. Slide connectors until they CLICK securely into profile. Use WD40 or liquid soap if pieces do not easily slide together. Wear gloves.

**7.2A** Lift front from inside and rest it next to sides. Line up connector S10 with profile L07A, connector S09 with profile L07B and connectors S04 and S05 with profiles L01C.

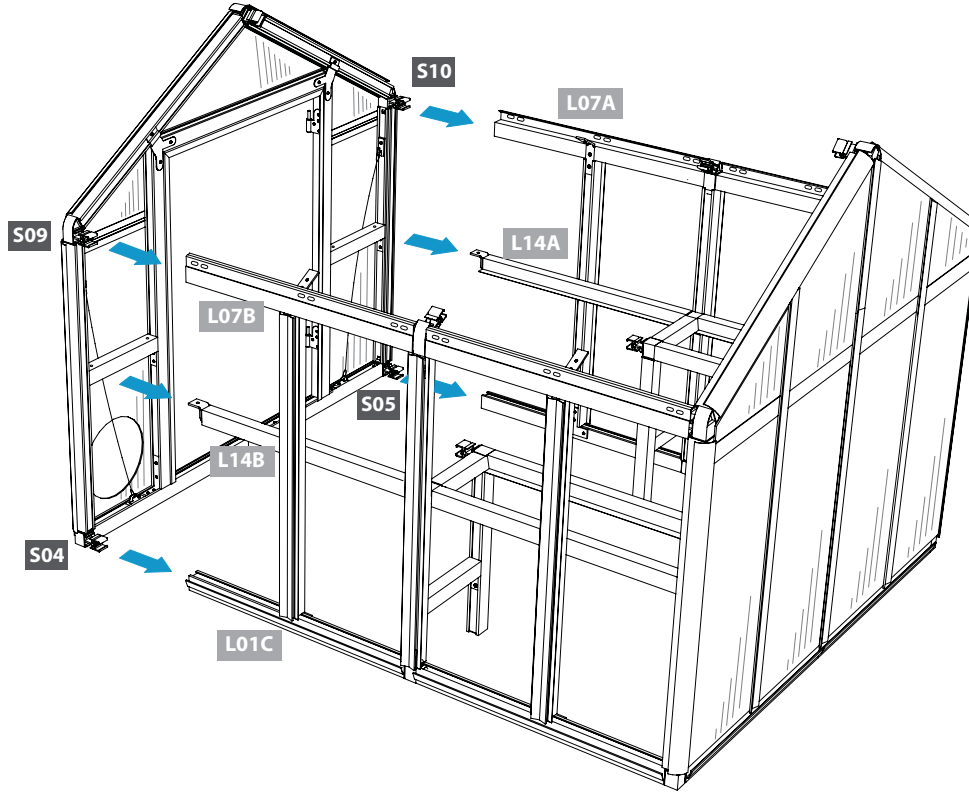

**7.2B** Carefully pull the front until all connectors are half way inside each profile. Make sure connector S37 attached to shelf profiles rest on top of profile L04A. Push front into sides until connectors click into place.

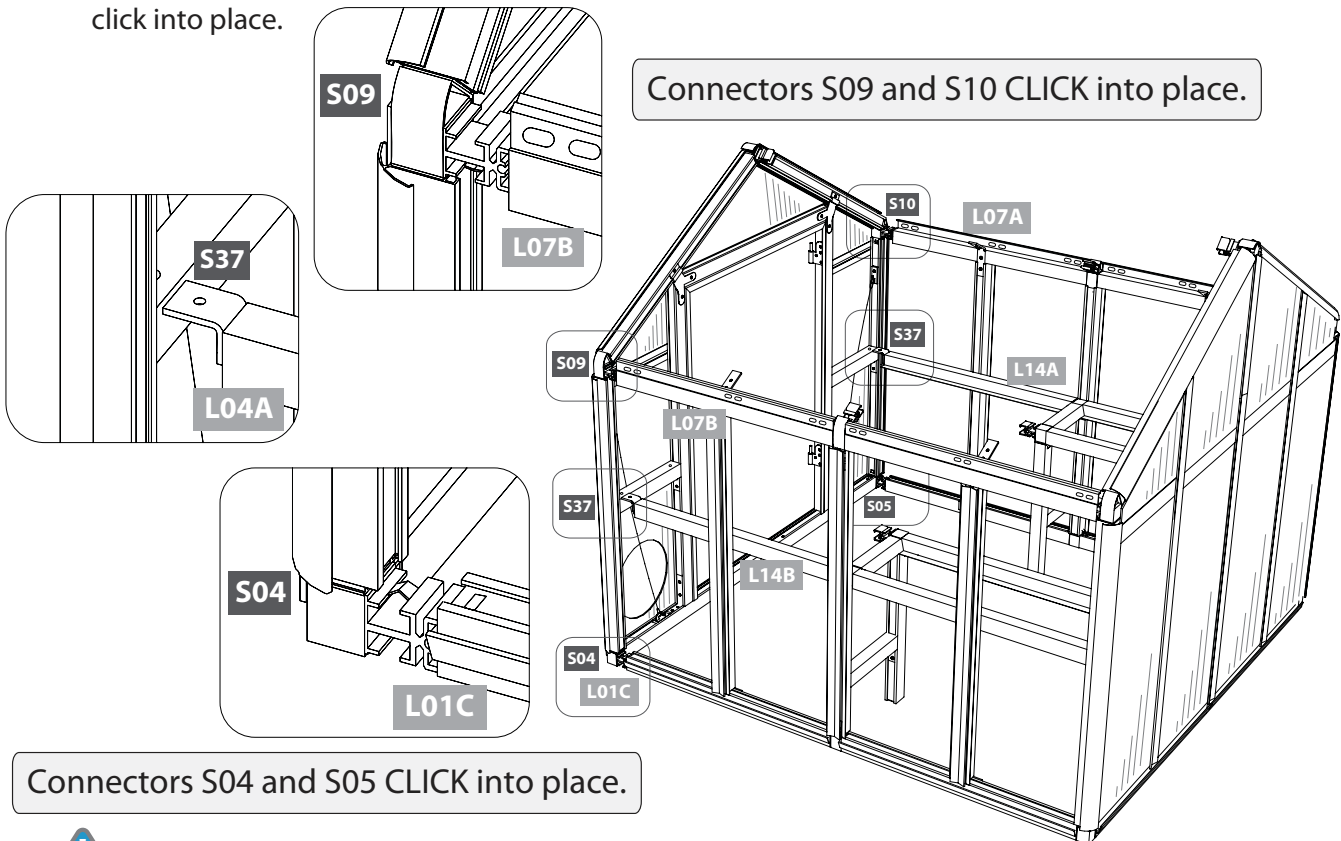

**!** There is only one way to properly fasten connectors into profiles. Line up parts first to ensure correct placement. Slide connectors until they CLICK securely into profile. Use WD40 or liquid soap if pieces do not easily slide together. Wear gloves.

**7.3A** Slide shelf profile L14C at a slight angle so one end slides half way into connector S39 and the other side with connector S37 rests on top of profile L04A. Continue to slide until profile clicks into connector S39.

Connector S39 CLICKS into place.

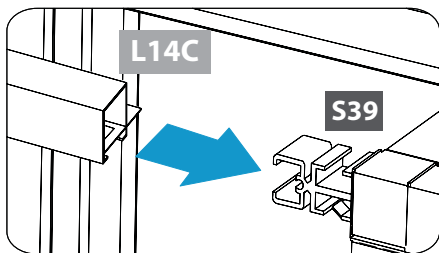

**!** There is only one way to properly fasten connectors into profiles. Line up parts first to ensure correct placement. Slide connectors until they CLICK securely into profile. Use WD40 or liquid soap if pieces do not easily slide together. Wear gloves.

**7.3B** Repeat step 7.3A, sliding shelf profile L14D into S39 connector. Make sure connector S37 rests on top of profile L04A.

Connector S39 CLICKS into place.

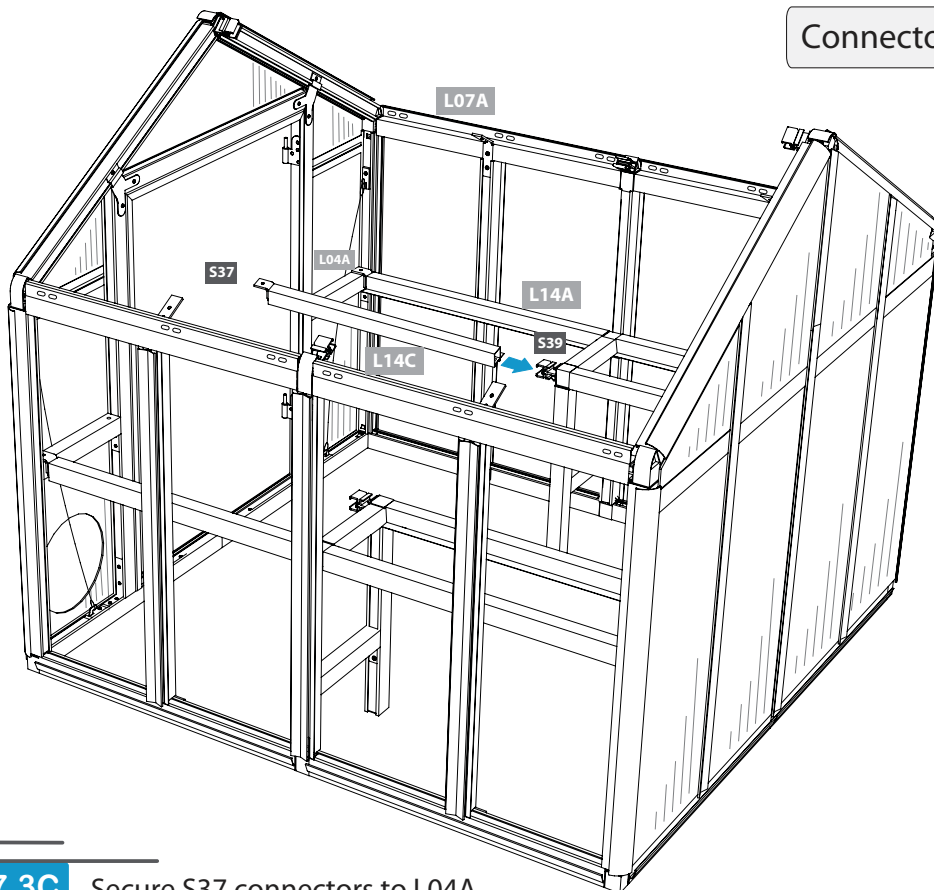
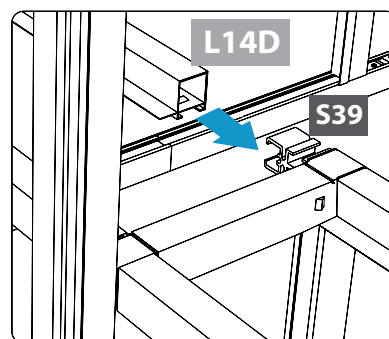

**7.3C** Secure S37 connectors to L04A profiles with four S02 screws.

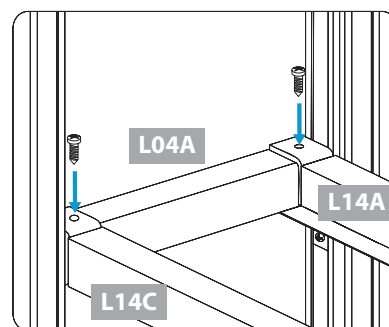
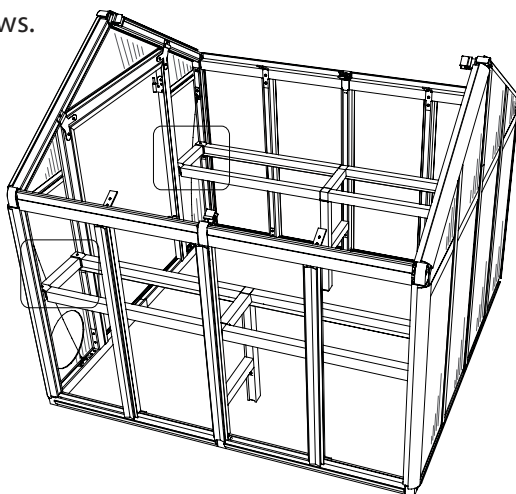
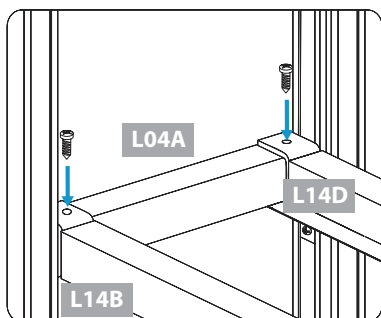

VIEWS FROM INSIDE.

Screw		QTY
	#S02	4

# Assemble and Connect Gables



Place all the parts for the gables on a level surface.  
 Make sure the pieces are in the correct positions before assembling.  
 Please carefully follow the order of assembly to ensure an easy installation.  
 Wear proper safety gear including shoes, gloves and goggles.

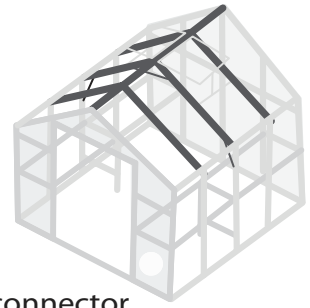

**8.1A** Slide connector S22 into channels of profiles L03M. Slide another S22 connector into channels of profiles L03O and L03P. **IMPORTANT:** U-shaped cutout is not at midpoint of profiles L03O and L03P. Attach longer side (34.5") to connector S22.

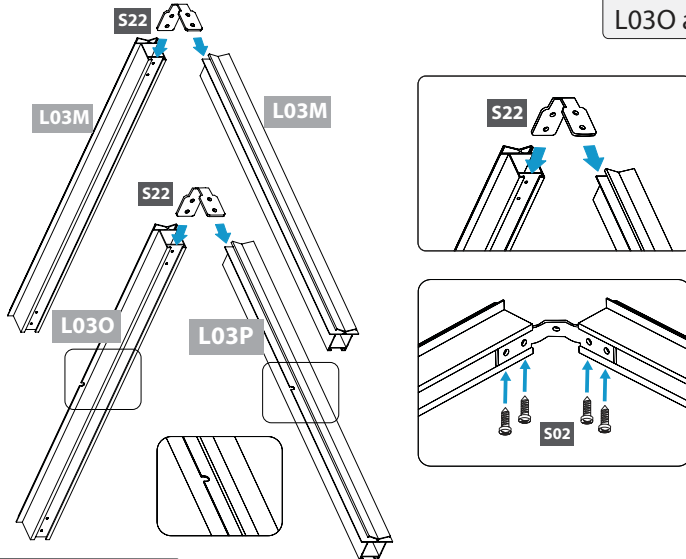

**8.1B** Secure each set with four S02 screws.

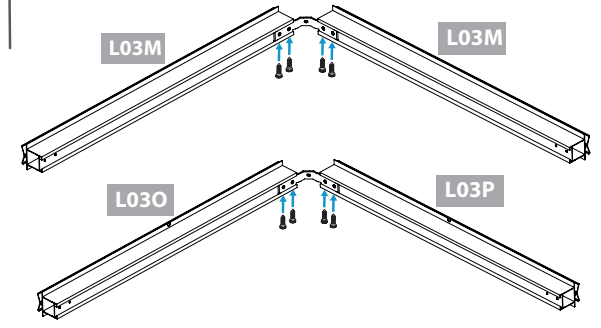

Profile	QTY	Connector	QTY
#L03M	2	#S02	8
#L03O	1	#S22	2
#L03P	1		

**8.2A** Slide connector S21 into profiles L03Q and L03N until it clicks securely into place.

**IMPORTANT:** U-shaped cutout is not at midpoint of profiles L03N and L03Q. Attach longer side (34.5") to connector S21. Make sure connector S21 is positioned correctly before connecting.

Connectors S21 **CLICKS** into place.

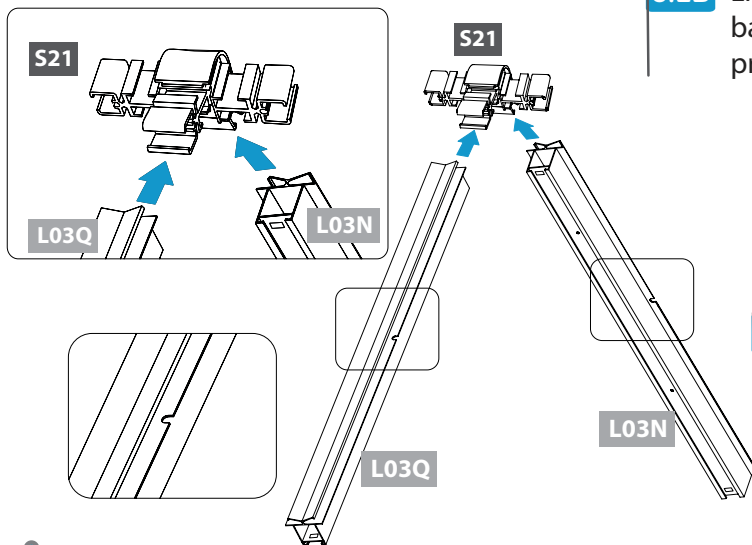

**8.2B** Line up holes on bracing bar S23 with holes in profiles L03Q and L03N.

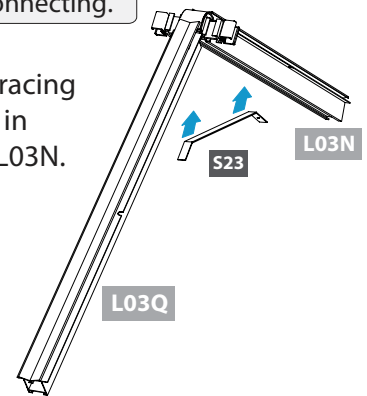

**8.2C** Secure brace to profiles with two S02 screws.

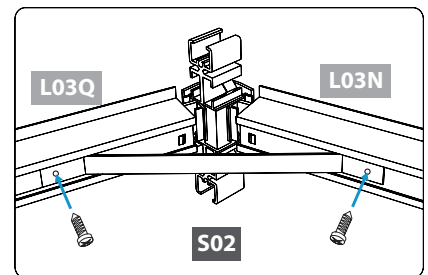

**!** There is only one way to properly fasten connectors into profiles. Line up parts first to ensure correct placement. Slide connectors until they **CLICK** securely into profile. Use WD40 or liquid soap if pieces do not easily slide together. Wear gloves.

Profile	QTY	Connector	QTY	Screw	QTY	Brace	QTY
#L03N	1	#S21	1	#S02	2	#S23	1
#L03Q	1						



### 8.3

From the inside of the greenhouse, use two people to carefully lower center gable onto frame. Line up and slide profiles L03N and L03Q into connectors S19 until they click securely into place.

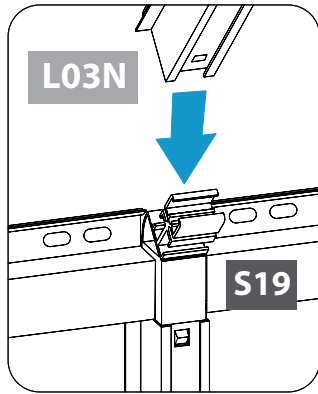

Connectors S19 CLICK into place.

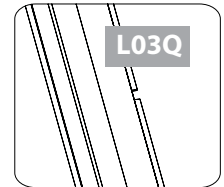
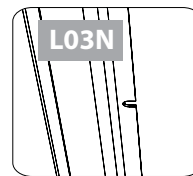
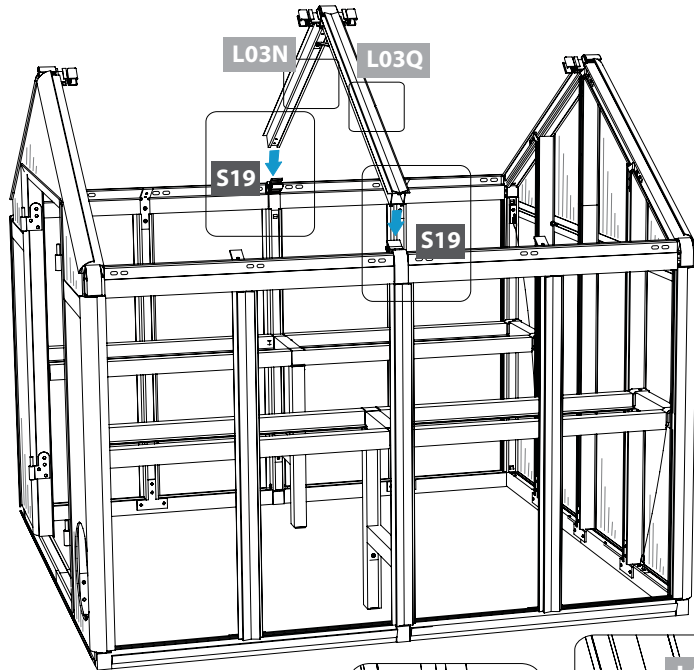
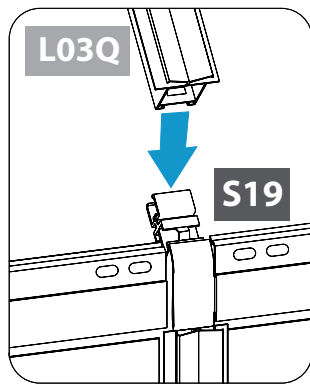

There is only one way to properly fasten connectors into profiles. Line up parts first to ensure correct placement. Slide connectors until they CLICK securely into profile. Use WD40 or liquid soap if pieces do not easily slide together. Wear gloves.

NOTE: U-shaped cutouts on profiles L03N and L03Q face the back.

### 8.4

From the inside of the greenhouse, use two people to carefully lower front and back gables onto frame. Line up and slide connectors S20 into channels of profiles L03M, L03O and L03P.

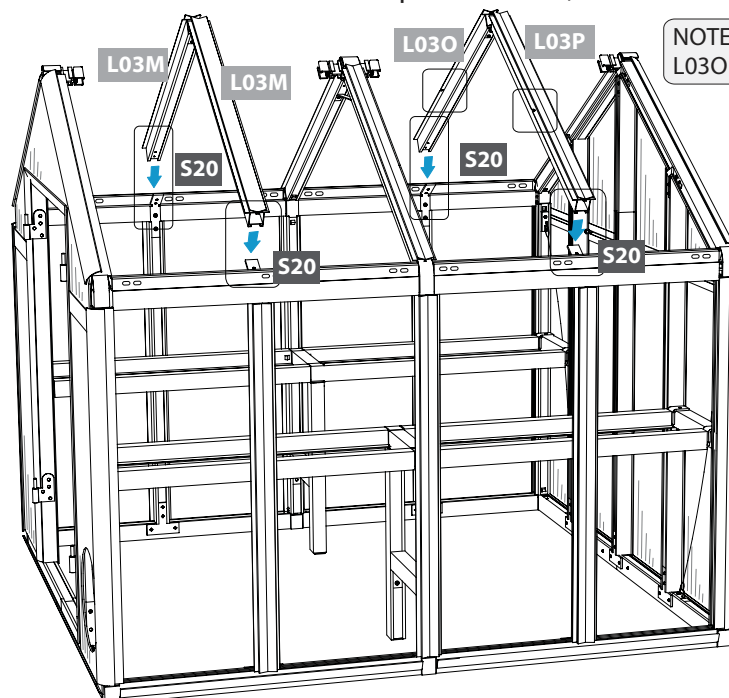
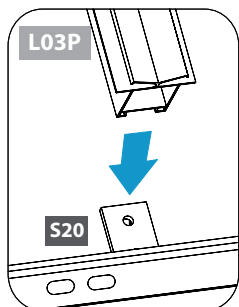
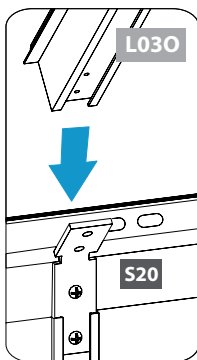

NOTE: U-shaped cutouts on profiles L03O and L03P face the front.

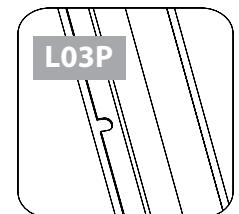

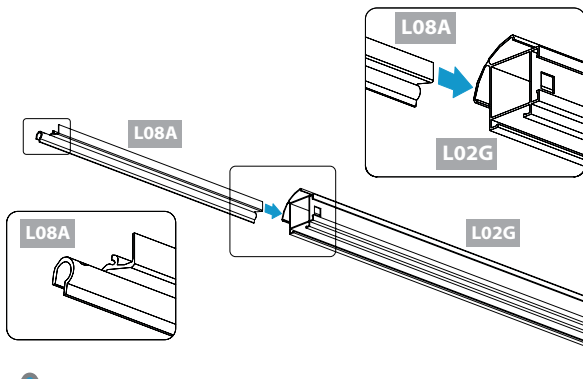

**8.5A** Line up profiles L08A and L02G as shown. L08A has a cutout on one end. The plain side slides into V-channel of profile L02G. Note the rectangular holes in the channels of profile L02G are NOT on the side next to the V-channel.

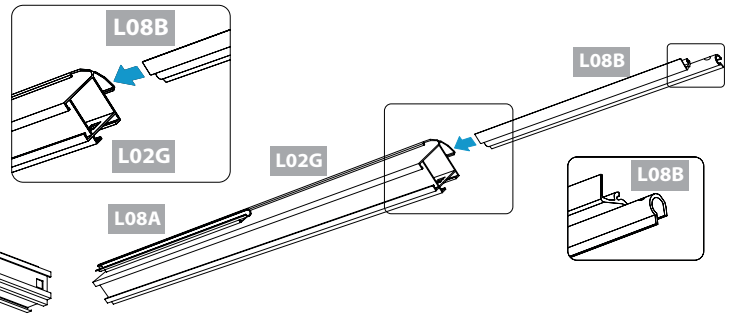

**8.5B** Slide the plain side of L08B into V-channel on opposite side of profile L02G.

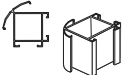

**!** **IMPORTANT:** There is one correct way to connect these profiles. Arrange profiles before sliding together. Use WD40 or liquid soap if parts do not easily slide together

Profile	QTY	Profile	QTY
 #L02G	1	 #L08A	1
		 #L08B	1

**8.6A** Using a small step ladder inside the greenhouse, carefully slide profile L02G with L08A and L08B connected into back connector S12 at a slight angle. Gently push center gable slightly towards the front to slide other end of profile into connector S21. Make sure both connectors snap securely into place. Note L02G profile rests on top of connector S22.

**IMPORTANT:** Make sure profiles L02G with L08B are in correct positions before installing. Arrange profile L02G so rectangular holes in channels face the LEFT when looking at the front of the greenhouse from the outside.

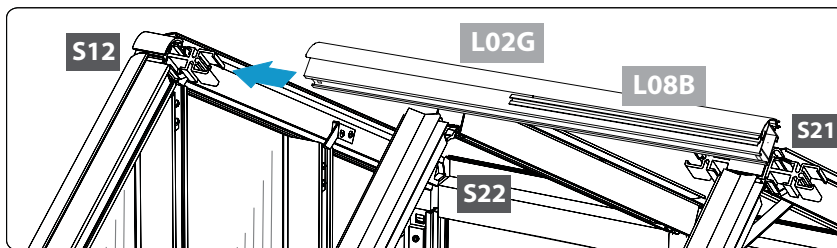

Connectors S12 and S21 **CLICK** into place.

**8.6B** Slide profile L02G at a slight angle into center gable connector S21. Gently push front side slightly forward to slide other end of profile into connector S18. Make sure both connectors click securely into place. Note profile L02G rests on top of connector S22.

**IMPORTANT:** Arrange profile L02G so rectangular holes in channels face the LEFT when looking at the front of the greenhouse from the outside.

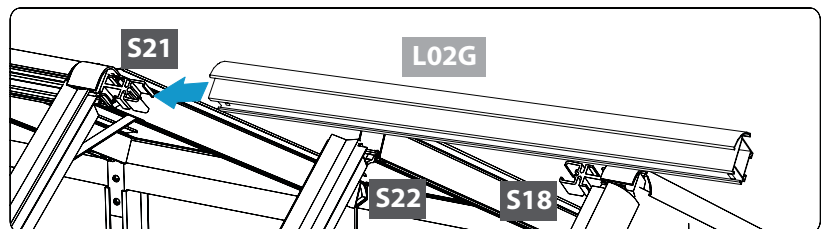
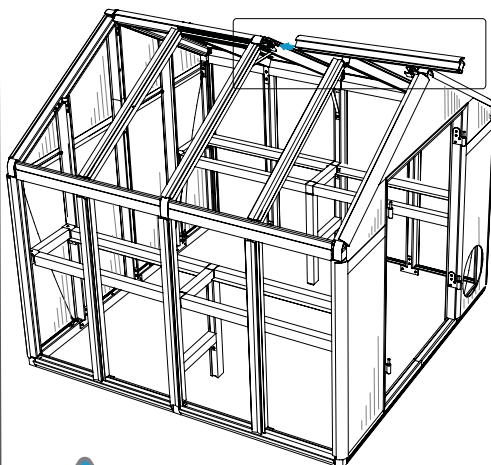

Connectors S21 and S18 **CLICK** into place.

**!** There is only one way to properly fasten connectors into profiles. Line up parts first to ensure correct placement. Slide connectors until they **CLICK** securely into profile. Use WD40 or liquid soap if pieces do not easily slide together. Wear gloves.

Profile	QTY
 #L02G	1

**8.7A** From inside of greenhouse secure S20 connectors to profiles L03M, L03O and L03P with two S02 screws.

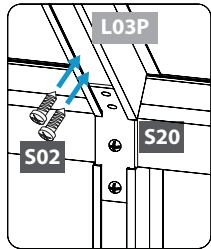
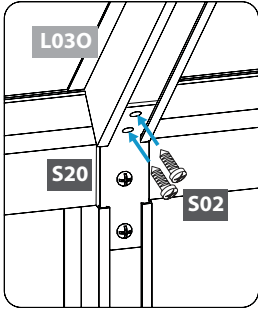

IEWS FROM INSIDE.

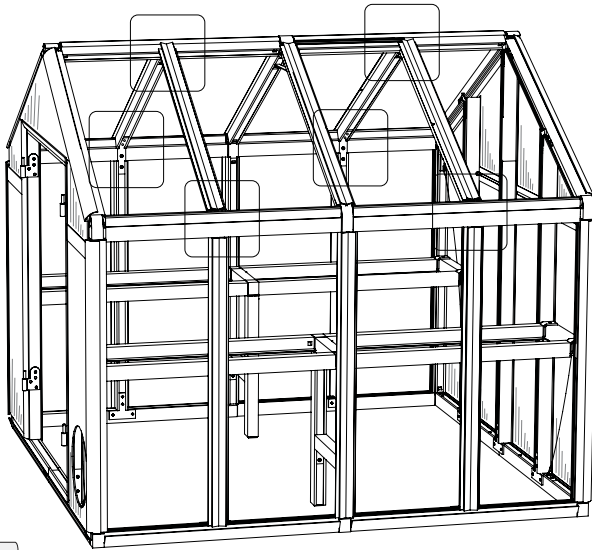

**8.7B** Secure S22 connectors to profiles L02G with one S02 screw.

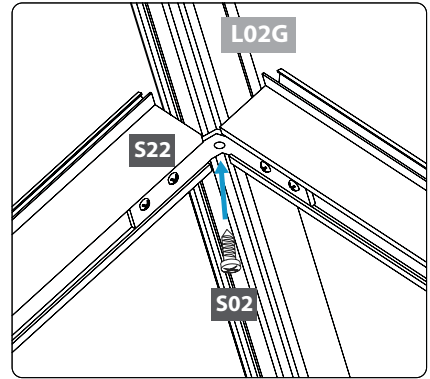

IEWS FROM INSIDE.

Screw		QTY
	#S02	10

**8.8A** From inside of greenhouse, line up bracing bar S23 with holes in profiles L03A and L03N. Secure one S02 screw partially into each end. Then go back and tighten both screws.

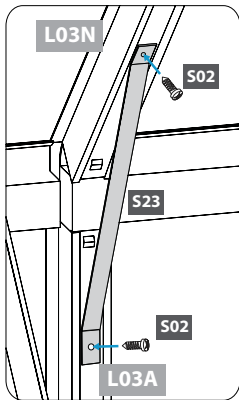
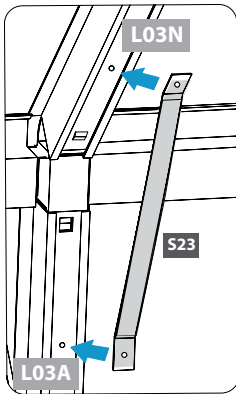

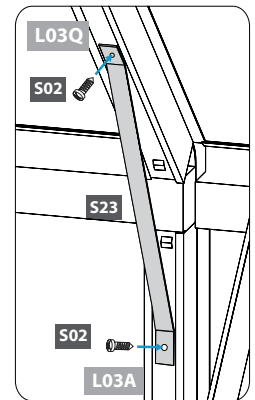
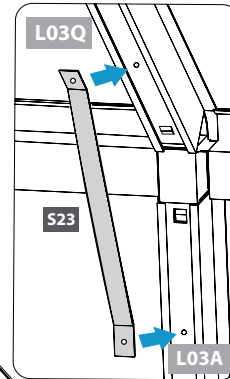

IEWS FROM INSIDE.

**8.8B** Line up bracing bar S23 with holes in profiles L03A and L03Q. Secure one S02 screw partially into each end. Tighten both screws.

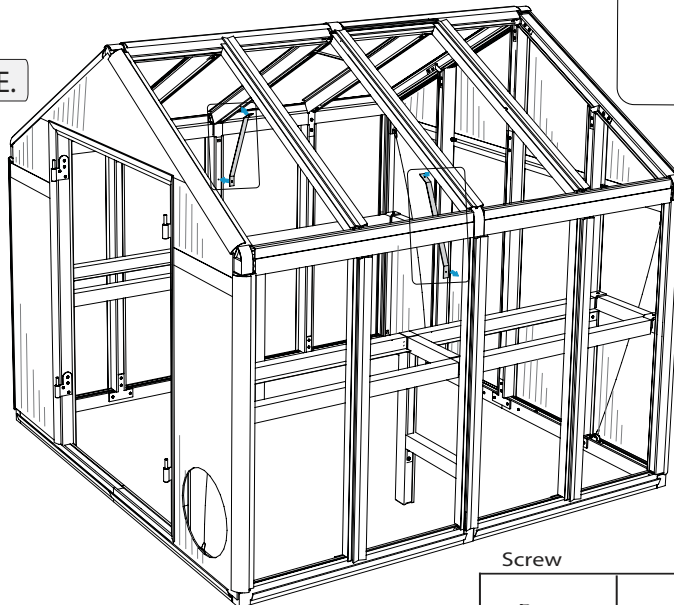

IEWS FROM INSIDE.

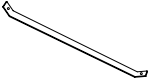

Screw		QTY	Brace		QTY
	#S02	4		#S23	2

# Brace Sides



Place all the parts for bracing the sides on a level surface.  
 Make sure the pieces are in the correct positions before assembling.  
 Please carefully follow the order of assembly to ensure an easy installation.  
 Wear proper safety gear including shoes, gloves and goggles.

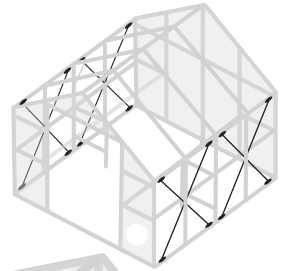

**9.1A** From the inside of the greenhouse, insert long side of cable connector S06 into profile channel L07B with hook facing the front. Slide connector to other side of channel. Use hex key to securely tighten and hold in place.

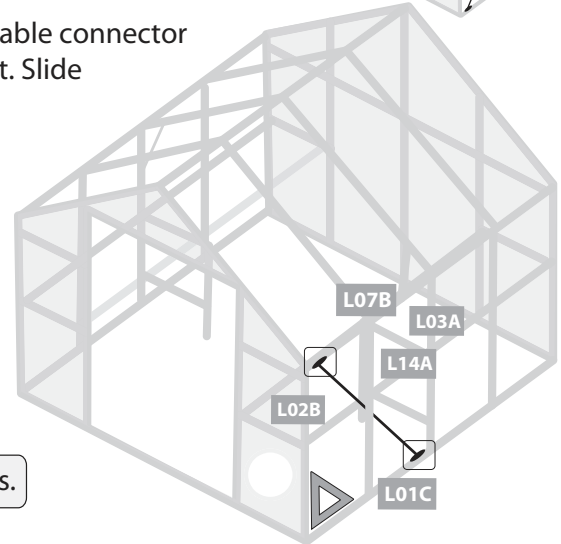
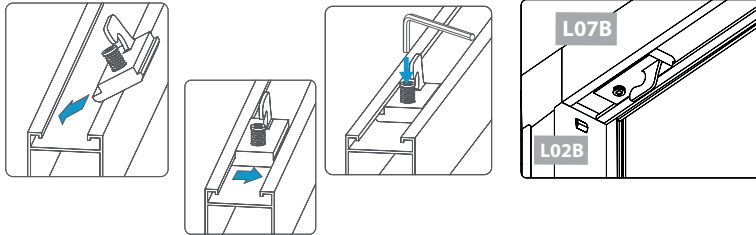

**IMPORTANT:** Make sure all corners are squared at 90 degrees.

**9.1B** Attach one side of long cable S07 to hook and lace behind profile L14A. Attach other side of cable to a second S06 cable connector. With hook facing the back, insert connector into profile channel L01C.

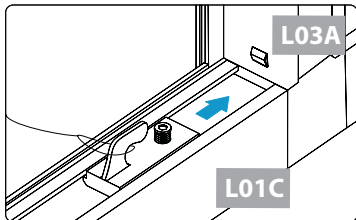

IEWS FROM INSIDE.

**9.1C** Push towards center until profile corners are square and cable is tight. Use hex key to securely tighten and hold in place.

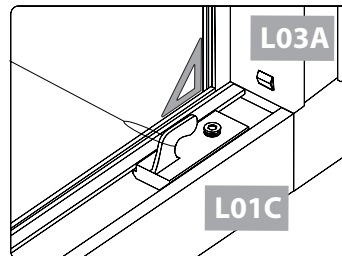

**IMPORTANT:** Make sure all corners are squared at 90 degrees.

**9.2** Repeat step 9.1 inserting cable connectors S06 into profile L07B with hook facing the back and into profile L01C with hook facing the front. Cable rests behind profile L14A. Slide connector until profile corners are square and cable is tight. Use hex key to securely tighten second connector and hold in place.

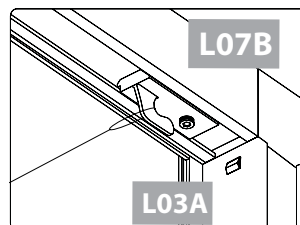
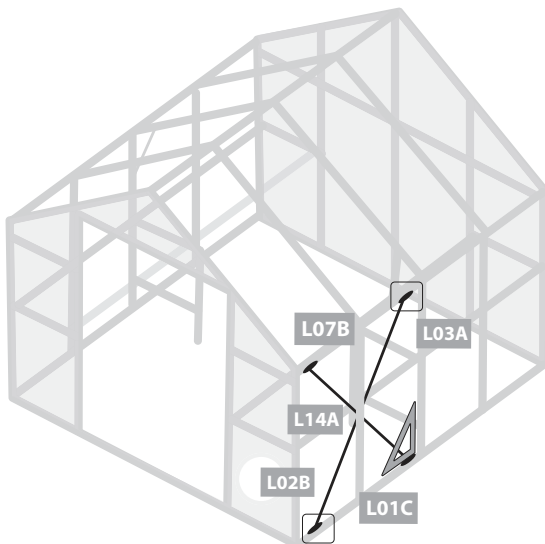

IEWS FROM INSIDE.

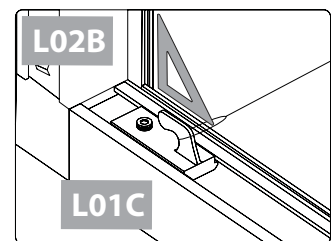

**IMPORTANT:** Make sure all corners are squared at 90 degrees.

Hex Key	QTY	Cable Connector	QTY	Cable	QTY
	1	#S06	4	#S07	2

**9.3A** From the inside of the greenhouse, insert long side of cable connector S06 into channel of profile L07A with hook facing the back. Slide connector to other side of channel. Use hex key to securely tighten and hold in place.

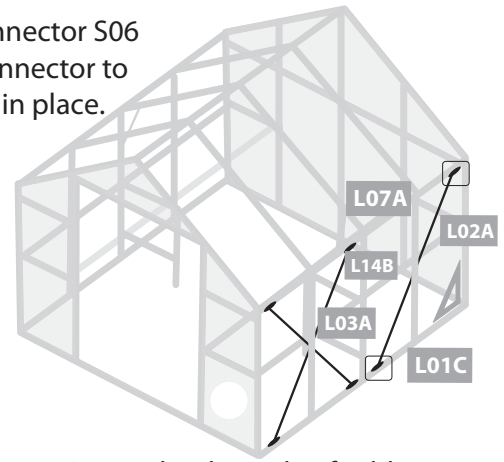
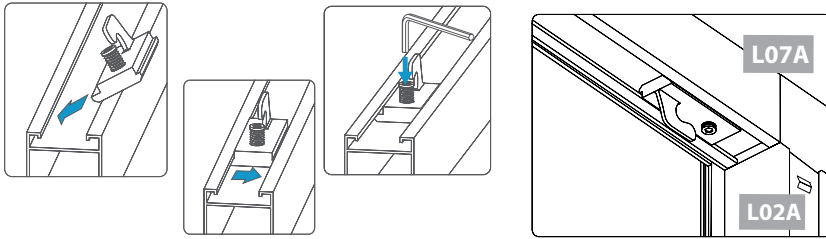

**9.3B** Attach one side of long cable S07 to hook and lace behind profile L14B. Attach other side of cable to a second S06 cable connector. With hook facing the front, insert connector into channel of profile L01C.

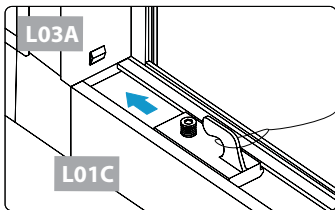

IEWS FROM INSIDE.

**9.3C** Push towards center until profile corners are square and cable is tight. Use hex key to securely tighten and hold in place.

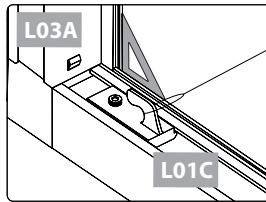

**IMPORTANT:** Make sure all corners are squared at 90 degrees.

**9.4** Repeat step 9.3 inserting cable connectors S06 into profile L07A with hook facing the front and into profile L01C with hook facing the back. Cable rests behind profile L14A. Slide connector until profile corners are square and cable is tight. Use hex key to securely tighten second connector to hold in place.

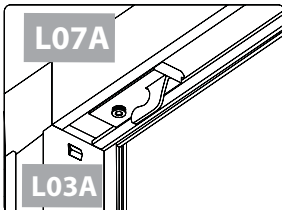

IEWS FROM INSIDE.

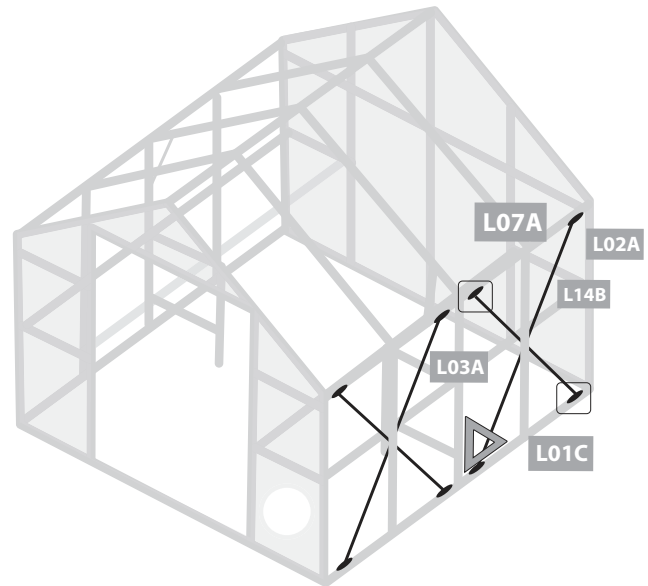
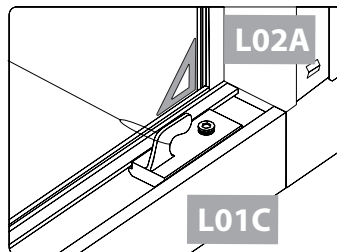

**IMPORTANT:** Make sure all corners are squared at 90 degrees.

**9.5** Repeat step 9.1 through 9.4 on the other side of the greenhouse.

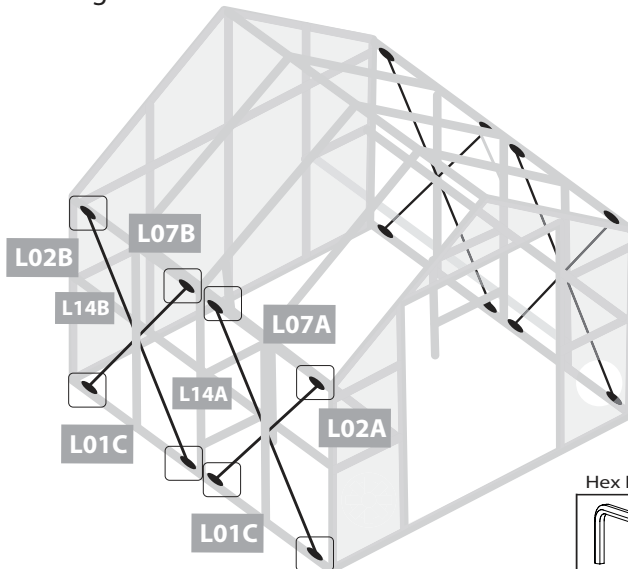

Hex Key	QTY	Cable Connector	QTY	Cable	QTY
	1	#S06	12	#S07	6

# Assemble and Install Roof Vents

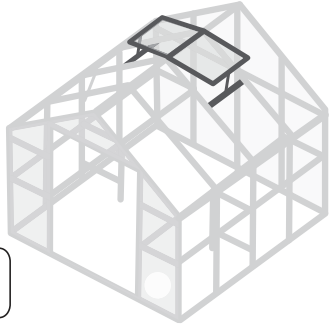

**!** Place all the parts for both roof vents and handles on a level surface. Make sure the pieces are in the correct positions before assembling. Carefully follow the order of assembly to ensure an easy installation. Wear proper safety gear including work shoes, gloves and goggles.

**!** The roof vents are assembled with the outside face to the ground. ALL VIEWS ARE SHOWN FROM INSIDE. Assemble BOTH vents first and then add the handles.

**IMPORTANT:** This greenhouse is equipped with one MANUAL vent handle (S25 installed in step 10.3) and one AUTOMATIC vent handle (auto vent opener installed in step 10.10). The auto vent opener is packed separately.

**10.1** Remove protective plastic from both sides of panels Y24. Place side to face toward the sun facing down. Fit panels into channels of profiles L10A and L11A.

**!** Remove protective plastic from EACH side of poly carbonate panels before installing. Dispose of plastic properly. Install with side labeled "Face this side towards the sun" FACING DOWN.

**10.2A** Fit panel and profiles L10A and L11A into channels of profiles L12B. Make sure holes in ends of profiles line up.

**10.2B** Secure with four S26 screws.

**NOTE: ALL VIEWS ARE FROM INSIDE.**

Screw	QTY	Profile	QTY	Profile	QTY	Profile	QTY	Panel	QTY	
	#S26		#L12B	4		#L10A	2		#Y24	2

**10.3** Attach handle S25 to profile L10A with two S24 screws. **NOTE:** You will install the handle to the second vent in step 10.10.

**IMPORTANT:** hollow side of handle S25 faces down when attached.

Handle	QTY	Screw	QTY	
	#S25		#S24	2

**10.4A** Unpack contents of Auto Vent Opener. Slide cylinder and piston rod through set collar on arm A.

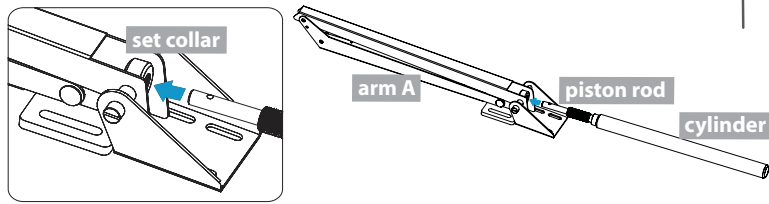

**10.4B** Continue sliding cylinder so piston rod fits into push arm and arm B begins to open. Align hole in piston rod with second hole in push arm. Insert hair pin clip to secure.

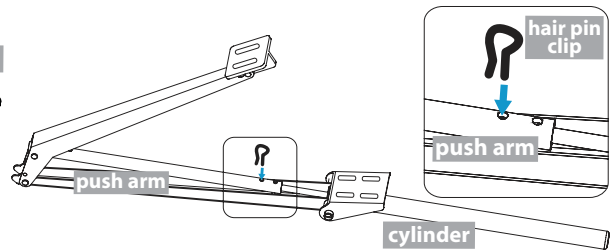

**10.4C** Slide cylinder so threaded area enters set collar. Turn cylinder clockwise to screw cylinder into set collar. As you continue turning, the piston rod forces the push arm back, pushing arm A and arm B together.

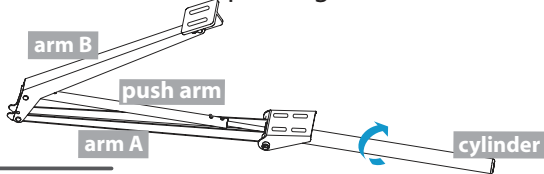

NOTE: The Auto Vent Opener will be installed to the vent in step 10.10

Handle	QTY	Cylinder with Piston	QTY	Hair Pin Clip	QTY
	1		1		1

**10.5A** Slide two S13 hex bolts into channel of profile L05D and four S13 hex bolts into channel of profile L05G.

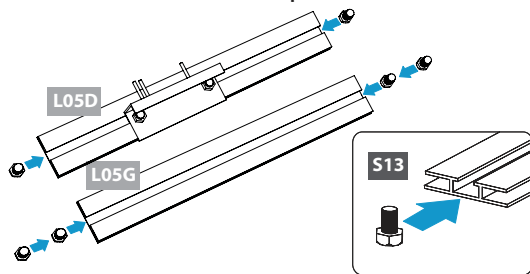

**10.5B** Screw two S14 hex nuts onto bolts on ends of each profile. Do not completely tighten.

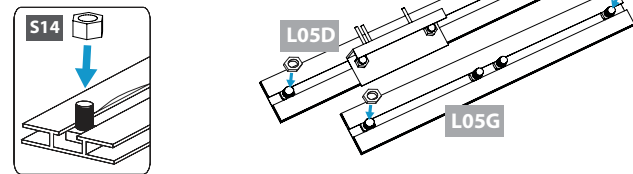

Profile	QTY	Profile	QTY	Bolt / Nut	QTY
	1		1		6
					4

**10.6A** With pins facing up on the inside of the greenhouse, slide one end of profile L05D into V-channel of profile L03P. Angle it slightly to fit the other end into V-channel of profile L03Q.

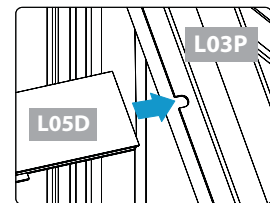
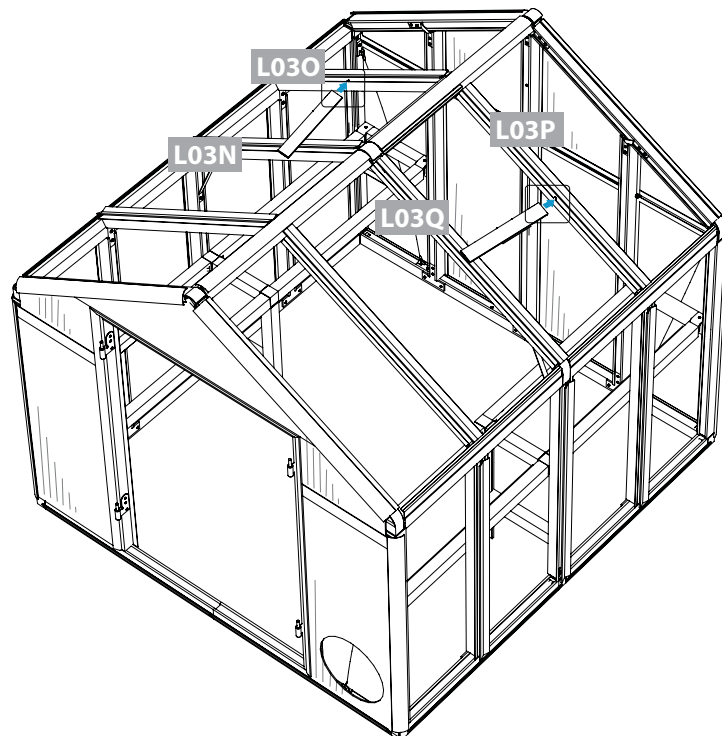

IMPORTANT: Make sure the pins face UP on INSIDE of the greenhouse when profile L05D is installed.

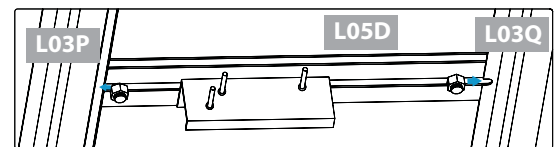

VIEW FROM INSIDE.

**10.6B** Line up L05D channel with U-shaped cutouts in sides of profiles L03P and L03Q. Slide hex nut and bolts into U-shaped notches and tighten securely.

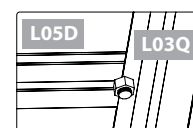
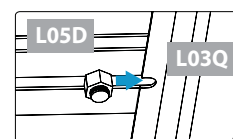

VIEWS FROM INSIDE.

**10.7** Repeat step 10.6 to install profile L05G on the other side of the greenhouse. With the nuts and bolts are facing the inside, secure profile L05G to profiles L03N and L03O.

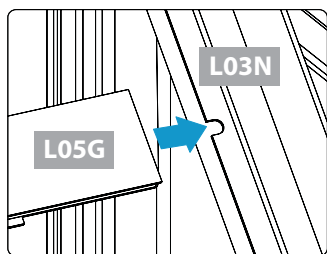

VIEW FROM OUTSIDE.

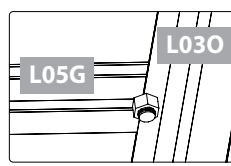
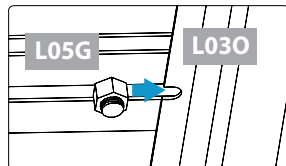
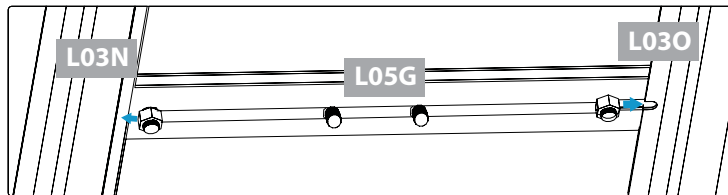

VIEW FROM INSIDE.

**10.8A** Stand on a small step ladder inside the greenhouse. Install roof vent with handle S25 to the right side of greenhouse. Slide profile L11A into profile L08A from the back of the greenhouse towards the front.

**IMPORTANT:** The handle of roof vent is on the inside of the greenhouse.

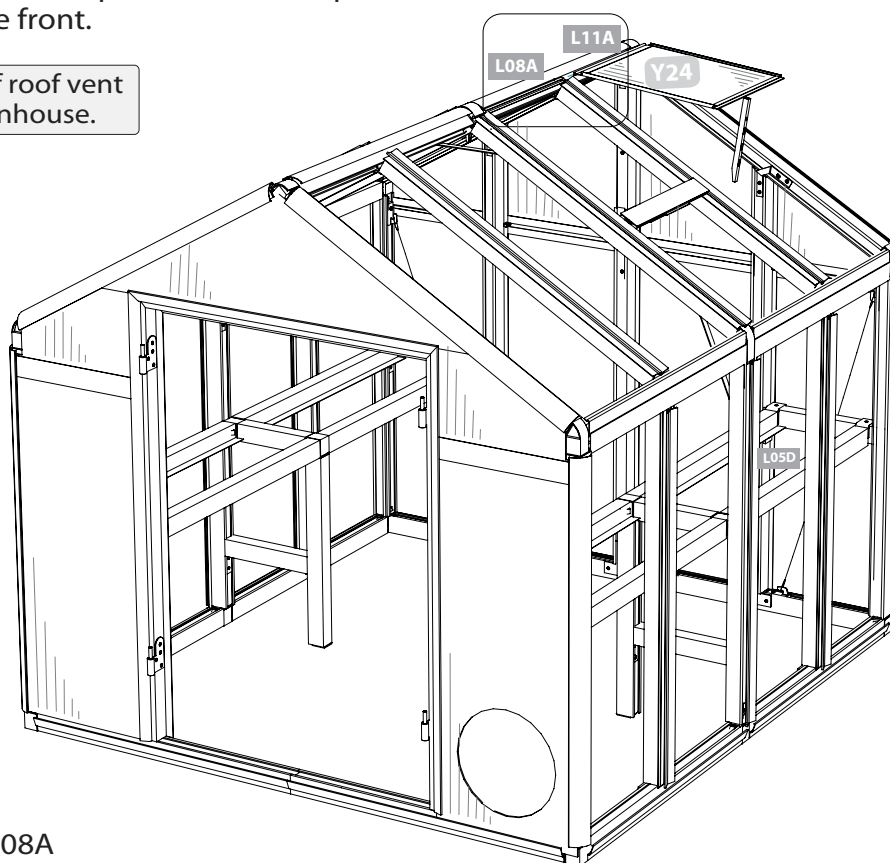
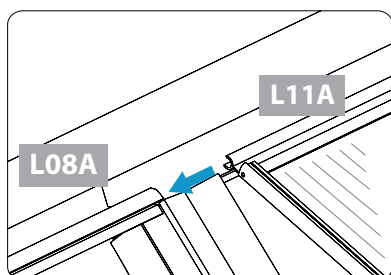

**10.8B** Continue to slide vent past the end of profile L08A until the hole in the other end is visible. Screw S24A into hole in L08A and slide vent back until it rests next to the screw.

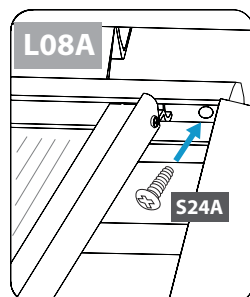
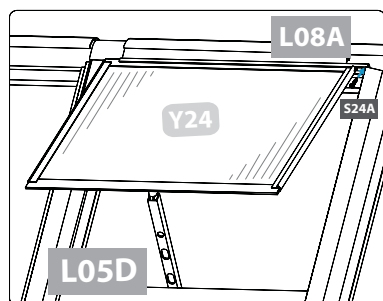



Screw	QTY
 #S24A	1

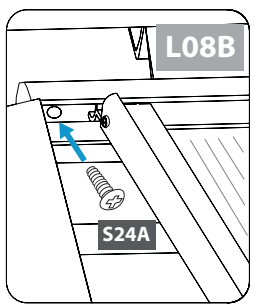
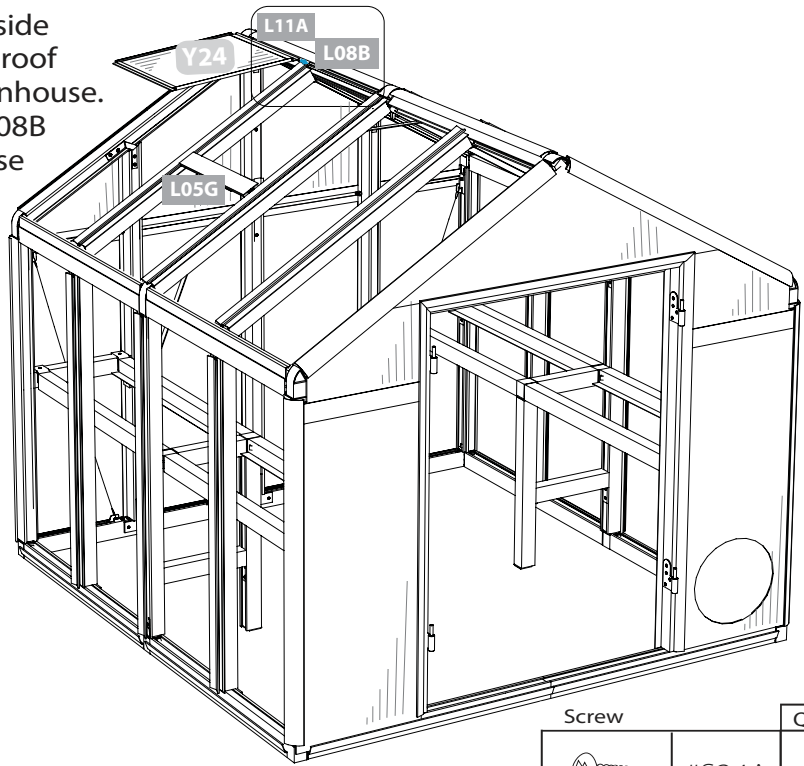

**10.9A** Stand on a small step ladder inside the greenhouse. Install second roof vent to the left side of the greenhouse. Slide profile L11A into profile L08B from the back of the greenhouse towards the front.

**10.9B** Continue to slide vent past the end of profile L08B until the hole in the other end is visible. Screw S24A into hole in L08A and slide vent back until it rests next to the screw.



Screw	QTY
 #S24A	1

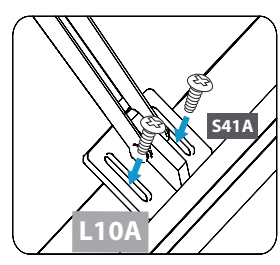
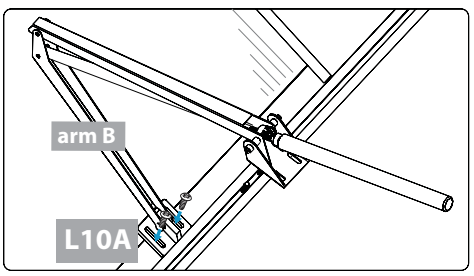

**10.10A** From the inside of the greenhouse open arms of auto vent slightly. Line up window bracket on arm B to holes in vent profile L10A and attach with two S41A screws.

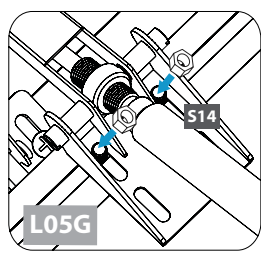
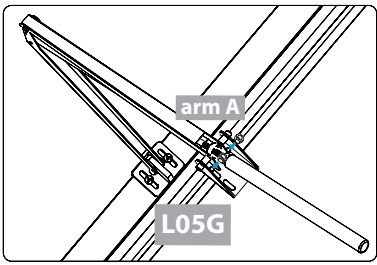

**10.10B** Slide bolts in channel of profile L05G until they fit into holes on end of arm A. Secure with two S14 hex nuts.



**NOTE: ALL VIEWS ARE FROM INSIDE.**

Nut / Screw	QTY
 #S14	2
 #S41A	2

**10.10C** Carefully push upper handle B down until vent closes completely. Turn cylinder clockwise until threaded area of cylinder is centered to set collar as shown.

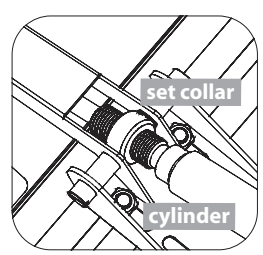
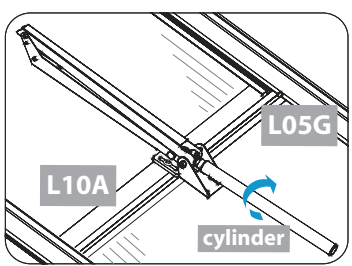

**IMPORTANT:** Tighten the cylinder when you finish or the auto vent will not function.

# Install Circular Vent



Place all the parts for circular vent on a level surface.  
 Make sure the pieces are in the correct positions before assembling.  
 Carefully follow the order of assembly to ensure an easy installation.  
 Wear proper safety gear including work shoes, gloves and goggles.

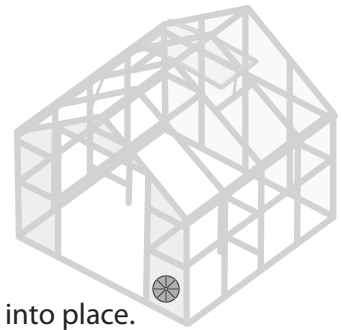

**11.1A** Open box containing the parts for circular vent. From the outside of the greenhouse, line up vent frame pins with holes in panel Y6, and slide into place. From the inside of the greenhouse, slide circular vent under the cable. Line up pins in vent frame with holes in circular vent and slide into place.

**IMPORTANT:** Circular vent rests under the bracing cable. See step 3.10 for detailed instructions on adjusting the cables.

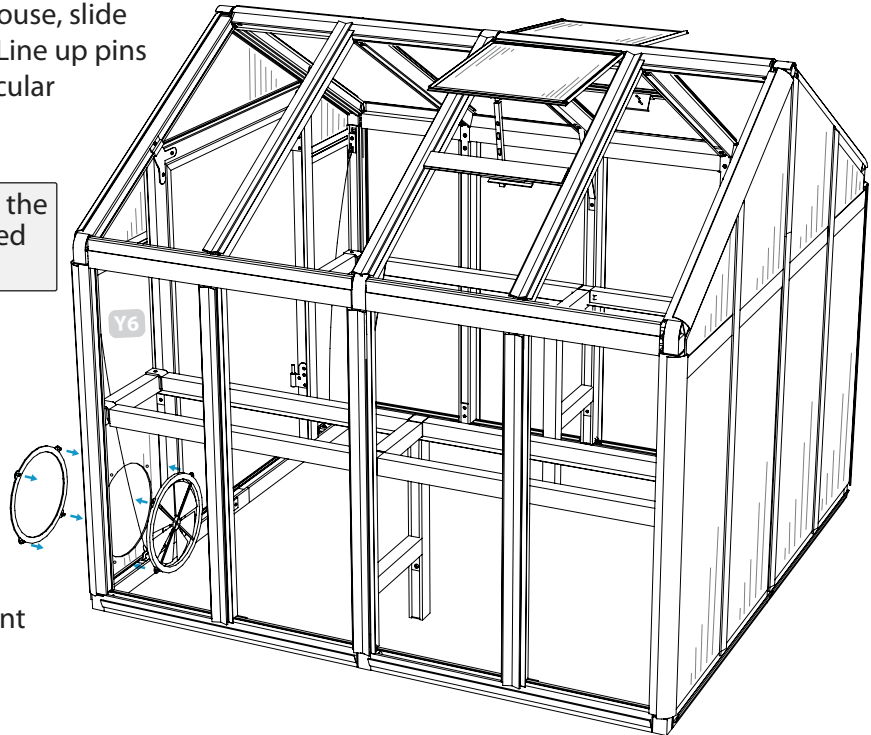

**11.1B** From the inside, secure the vent with four plastic nuts.

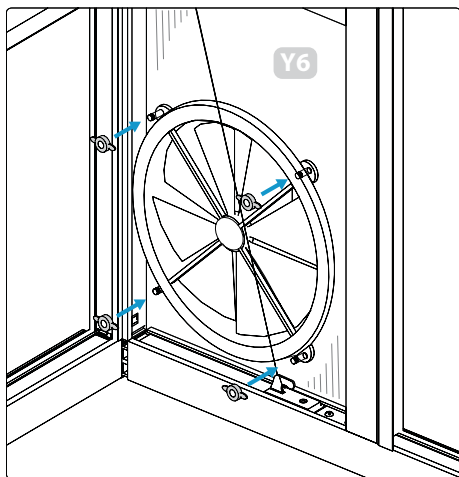

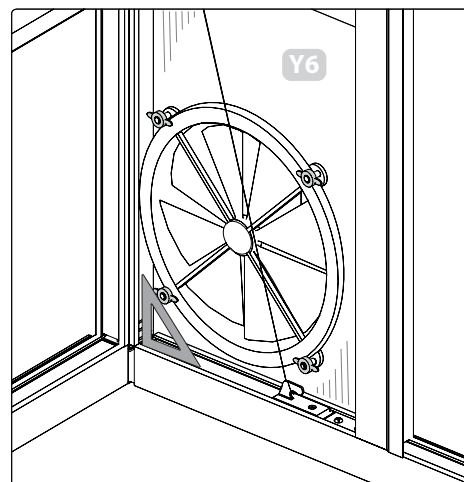

**11.1C** Double check that the profile corners are squared at 90 degrees and adjust if necessary. See step 3.10 for detailed instructions.



**NOTE:** VIEWS ARE FROM INSIDE.

**IMPORTANT:** Make sure all corners are squared at 90 degrees.

Vent Frame	QTY	Circular Vent	QTY	Plastic Nuts	QTY
	1		1		4

# Install Side and Roof Panels



Place all side and roof panels on a level surface. Make sure the pieces are in the correct positions before assembling. Carefully follow the order of assembly to ensure an easy installation. Wear proper safety gear including work shoes, gloves and goggles.

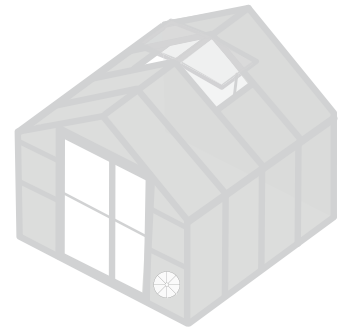

**12.1** Remove protective plastic from both sides of panels Y9 and Y10. Place side to face toward the sun facing out when installing. Slide panels carefully into V-channels in corner profiles L02A and L02B and side profiles L03A and L03B. As you continue sliding the panels make sure they fit into the V-channels in base profiles L01C.

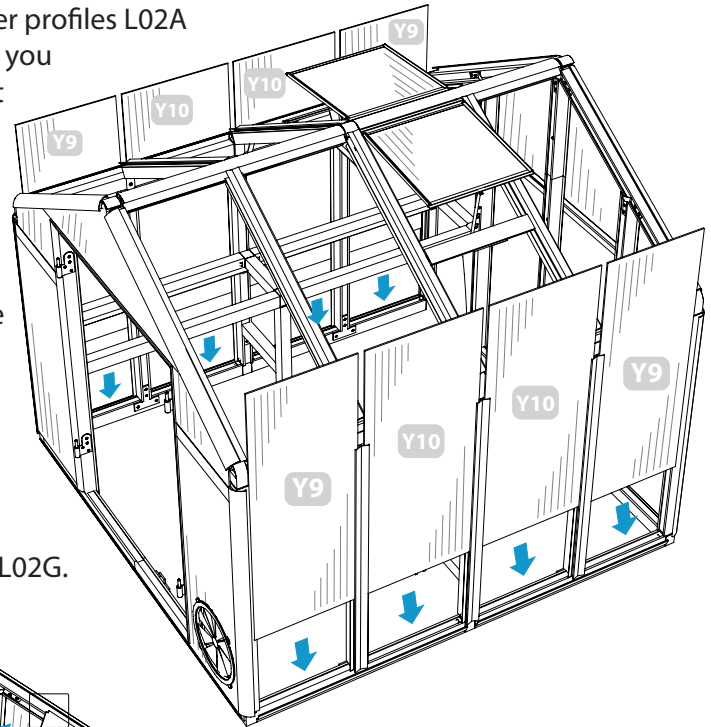

**12.2** Remove protective plastic from both sides of panels Y21, Y22 and Y23. Place side to face toward the sun facing out when installing. Slide panels carefully into V-channels in gable profiles L03M, L03N, L03O, L03P and L03Q and into V-channels of front and back profiles L02I, L02J, L02K and L02L. As you continue sliding the panels make sure they fit into the V-channels in center roof profiles L02G.

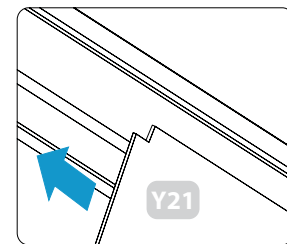
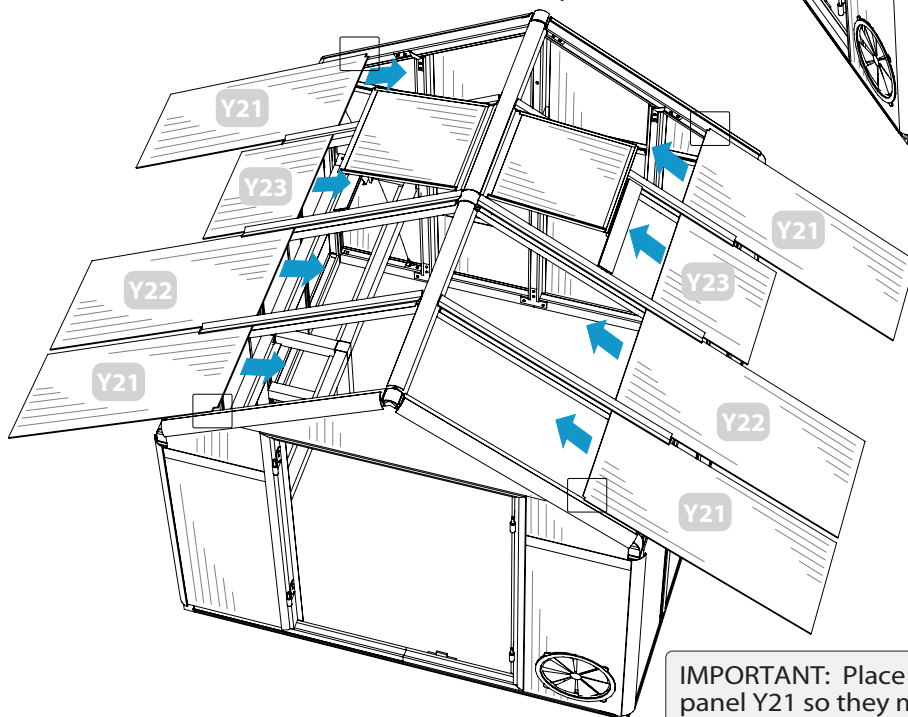

**IMPORTANT:** Place rectangular cutout in corner of each panel Y21 so they meet at top front and top back corners. You will install two left and two right Y21 panels.



Remove protective plastic from EACH side of poly carbonate panels before installing. Dispose of plastic properly. Install with side labeled "Face this side towards the sun" FACING OUT.

Panel	QTY	Panel	QTY
	#Y9 4		#Y10 4
	#Y21 4		#Y22 2
	#Y23 2		

# Install Weather Stripping



If you have been assembling your greenhouse in another place than it's final position, we recommend you move the greenhouse before you begin these steps. Have at least one person help you carry it.



**NOTE:** You will find a roll of 80 meters of black rubber weather stripping. You will need a pair of scissors for this step.

13

From the outside of the greenhouse, line up the black rubber stripping with the V-channels of all profiles. Cut to length of each profile as you work, pushing the stripping between the panel and the empty space in the V-channel of the profile.



**IMPORTANT:** The black rubber stripping J01A is cut to length with scissors. Make sure to insert stripping as shown, securely into the V-channels of all the profiles, cutting each piece to the proper length. This will help protect the inside of your greenhouse from the weather.

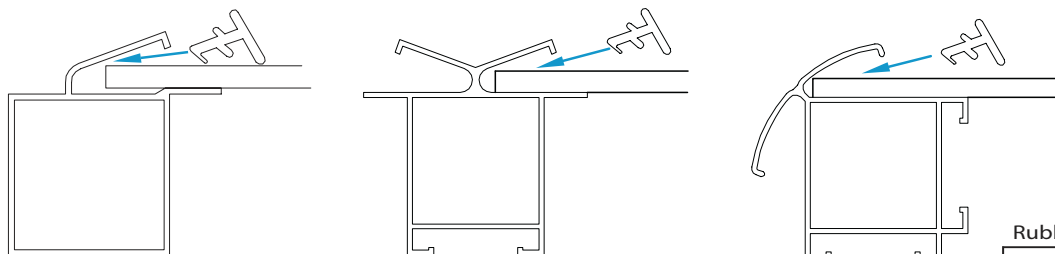

Rubber Stripping	QTY
	#J01A 80M

# Install Trim Plates



Place the trim plates on a level surface. Make sure the pieces are in the correct positions before assembling. Carefully follow the order of assembly to ensure an easy installation. Wear proper safety gear including work shoes, gloves and goggles.

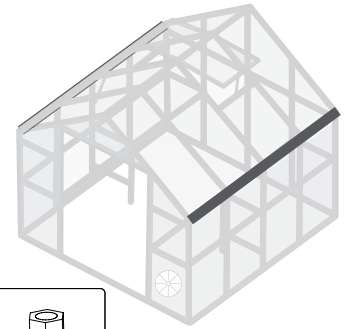

**14.1** Remove the six hex nuts from the hex bolts attached to each L09A and L09B trim plate BEFORE installing.

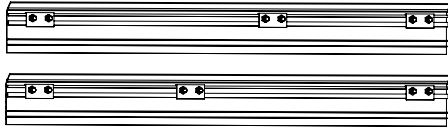

L09A

L09B

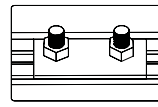

VIEWS FROM INSIDE.

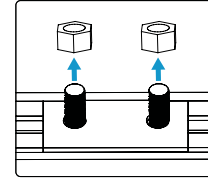

**14.2A** Place trim plates L09A and L09B onto profiles L07A and L07B on outside of greenhouse. Trim plates fit over edges of side and roof panels and bolts are inserted into holes on profiles L07A and L07B.

NOTE: Trim plates cover edges of black rubber stripping, and roof and side panels.

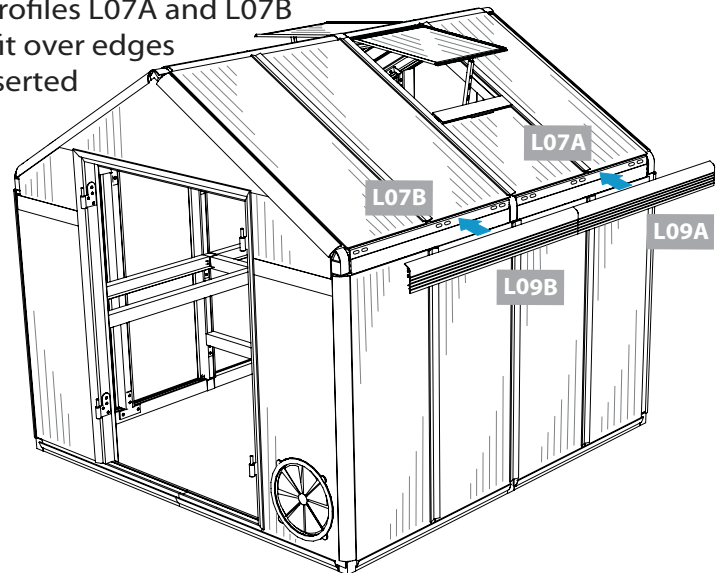

**14.2B** From inside of greenhouse, place hex nuts onto hex bolts in trim plates L09A and L09B and tighten securely.

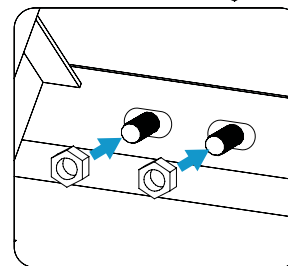
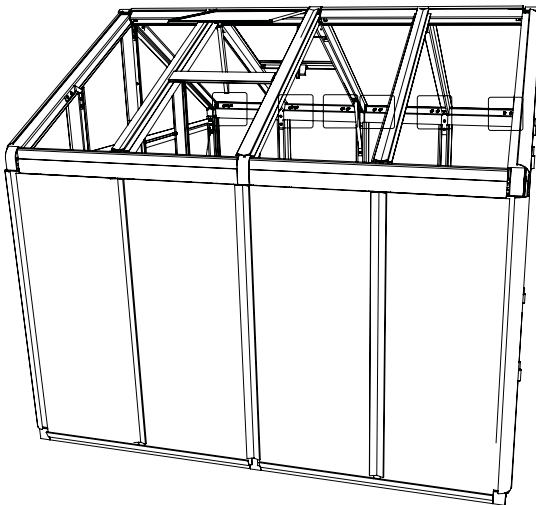



VIEWS FROM INSIDE.

IMPORTANT: The holes in profile L07A and L07B and the bolts in trim plates L09A and L09B are in different positions. Fit trim plate L09A into profile L07A. Fit trim plate L09B into profile L07B.

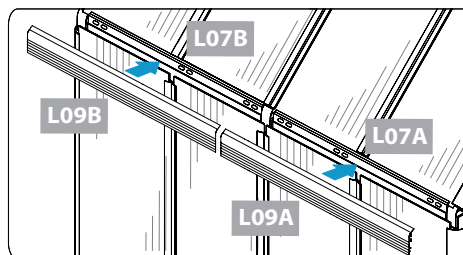
**14.3** Repeat Step 14.2A and 14.2B on other side of greenhouse. Note the positions of profiles L07A and L07B are reversed. Make sure to attach trim plate L09A to profile L07A in the front and trim plate L09B to profile L07B in the back.



Trim Plate		QTY
	#L09A	2
	#L09B	2

**14.4A**

In the front of the greenhouse, slide plastic trim plates J02L, J02R, and J03 into connectors S09, S10 and S18 until they snap into place. On top of the greenhouse, snap trim plate J06 onto connector S21. The trim plates will cover the edges of the black rubber stripping installed in step 13.

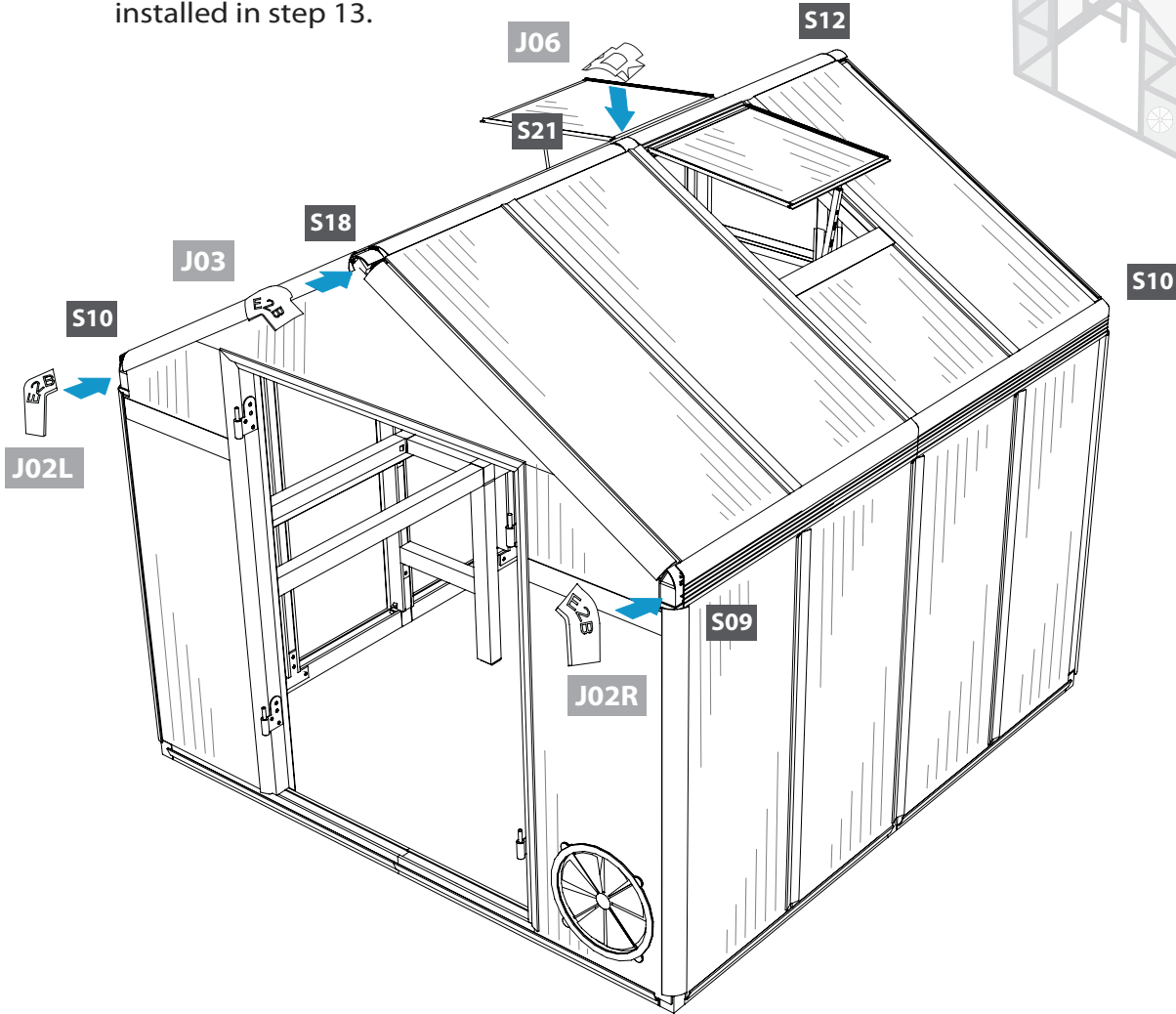
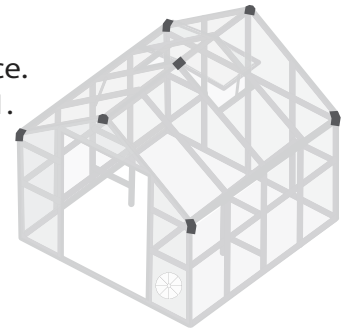



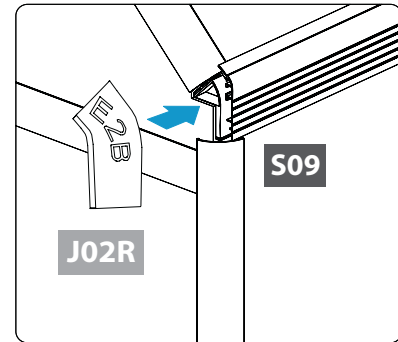
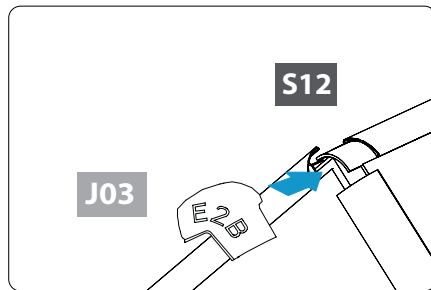
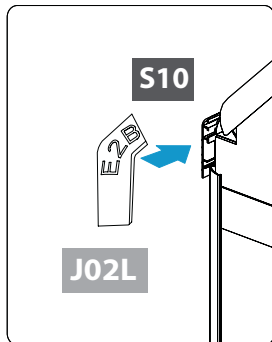

**14.4B**

In the back of the greenhouse, slide plastic trim plates J02L, J02R, and J03 into connectors S09, S10 and S12 until they snap into place.



**IMPORTANT:** The plastic trim plates J02L, J02R, J03 and J06 fit into connectors only one way. Make sure the connectors are snapped securely into place as they will protect the connectors from the weather.

Trim Plate	QTY	Trim Plate	QTY	Trim Plate	QTY	Trim Plate	QTY
 #J02L	2	 #J02R	2	 #J03	2	 #J06	1

# Weather Strip and Hang Doors



The doors have been assembled in step 2. When hung, the bracing bar on the large door and the door locks on the small door are on the inside of the greenhouse. We recommend using two people to hang the doors.

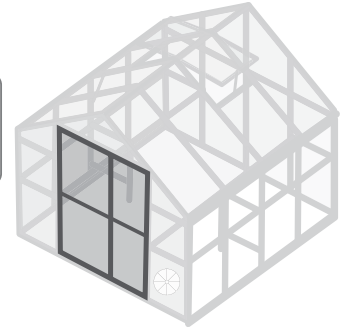

NOTE: You will use the remainder of the roll of 80 meters of black rubber weather stripping. You will need a pair of scissors for this step.

**15.1** Follow instructions for step 13 to install rubber weather stripping to outside of doors.

**IMPORTANT:** The rubber stripping J01A is cut to length with scissors. Make sure to insert stripping as shown, securely into the V-channels of all the profiles, cutting each piece to the proper length. This will help protect the inside of your greenhouse from the weather.

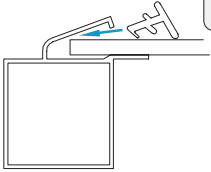

Rubber Stripping	QTY
 #J01A	80M

**15.2A** From the outside of the greenhouse, carefully line up hinges on small door into hinges on right side of door frame and lower into place. Turn the small door locks so they latch into place.

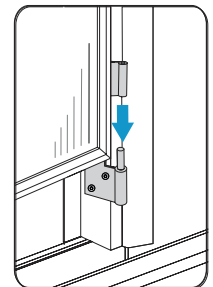
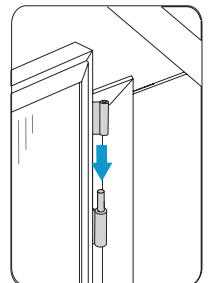
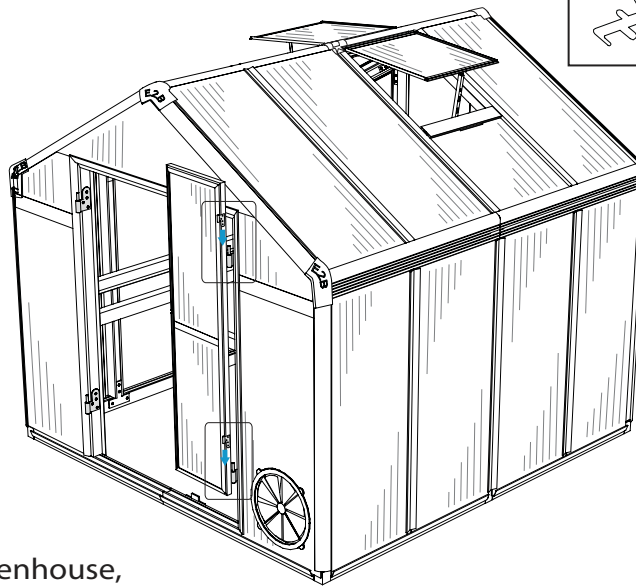

**15.2B** From the outside of the greenhouse, carefully line up hinges on large door into hinges on left side of door frame and lower into place. There is no need to secure it.

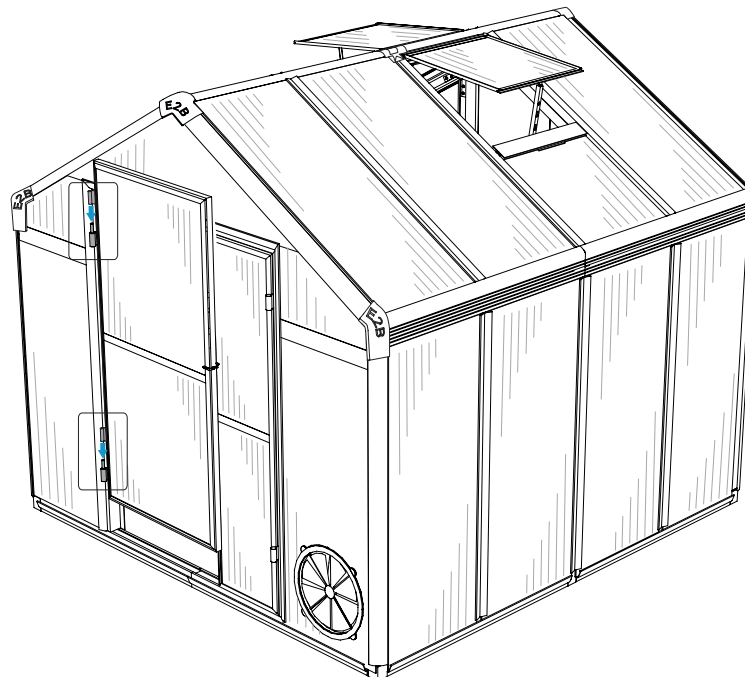
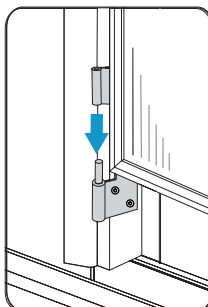
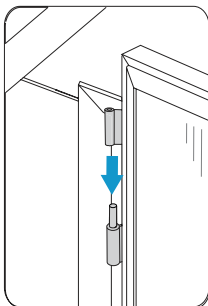

# Secure to Ground



**IMPORTANT:** The greenhouse must be firmly secured to the ground. Make sure the foundation is **FLAT** and **LEVEL**. Make sure the greenhouse is square. The two diagonal measurements inside the greenhouse should be identical.

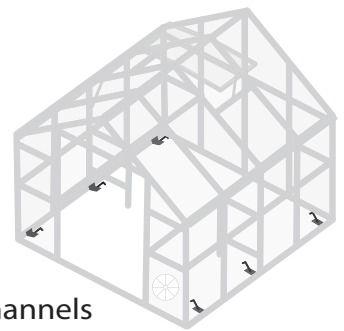

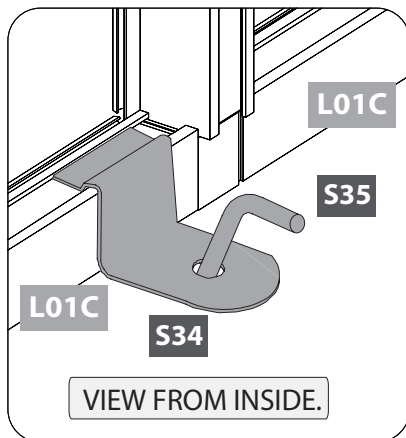

- 16** From the inside of the greenhouse, insert the S34 anchor clips into channels of side profile L01C at each corner and center of both sides. Place the S35 pegs through the holes and into the ground to establish proper placement. Remove the pegs, dig holes 12"/30cm deep and fill with concrete. When the concrete is partially dry, use a hammer to drive the pegs all the way into the concrete and let dry completely for twenty four hours.

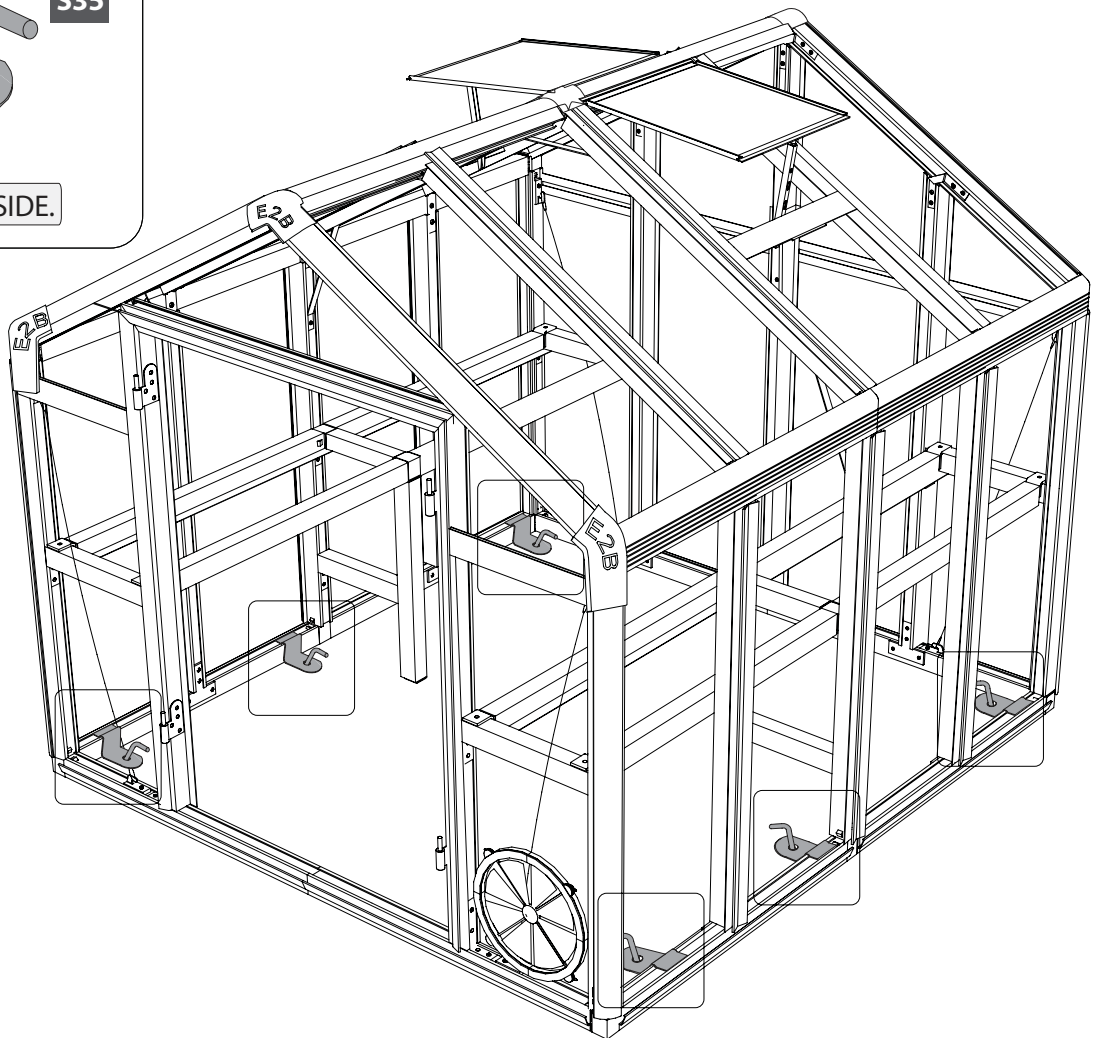

**NOTE:** Insert S34 anchor clips into the channel of side profiles L01C at a slight angle and slide under the lip of the channel.

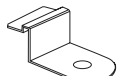

Anchor Clip	QTY	Anchor Peg	QTY
 #S34	6	 #S35	6



# Install Trays and Bin Holder



Place all the parts for the trays and bin holder on a level surface. Make sure the pieces are in the correct positions before assembling. Carefully follow the order of assembly to ensure an easy installation. Wear proper safety gear including work shoes, gloves and goggles.

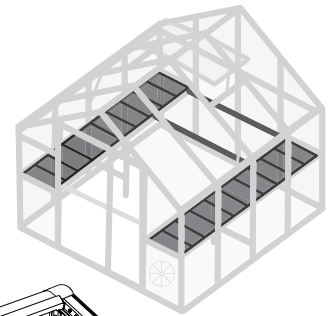

**17.1** From the inside of the greenhouse, place the trays on the shelves. The trays interlock together and rest on the lip on the sides of the shelf profiles. Ten trays fit on each side of the greenhouse.

**17.2A** Slide long side of connector S37 into each end of profiles L04G, lining up the last hole on the connector with the hole in the channel.

**17.2B** Secure each S37 connector with one S02 screw.

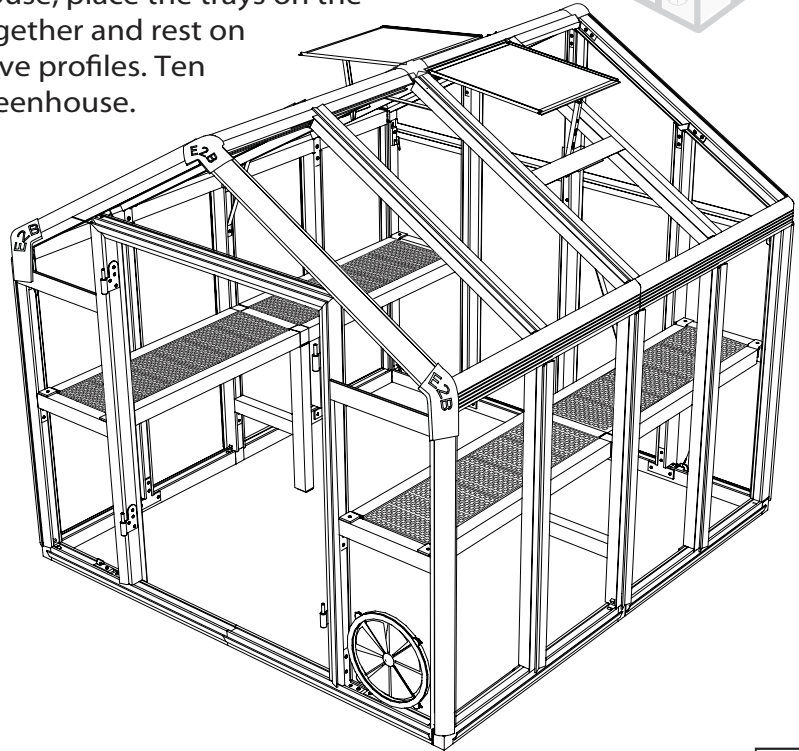
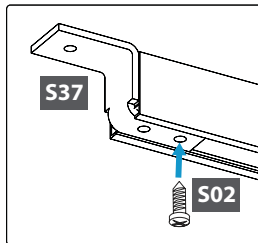

Trays		QTY
	#J05	20



**IMPORTANT:** S36 are self tapping screws used to screw into areas that do not have predrilled holes. When you have decided on the placement of your bin, use these screws to attach the L04G profiles into the shelf profiles.

**17.3A** Place profiles L04G on shelf profiles. Position to fit your bin.

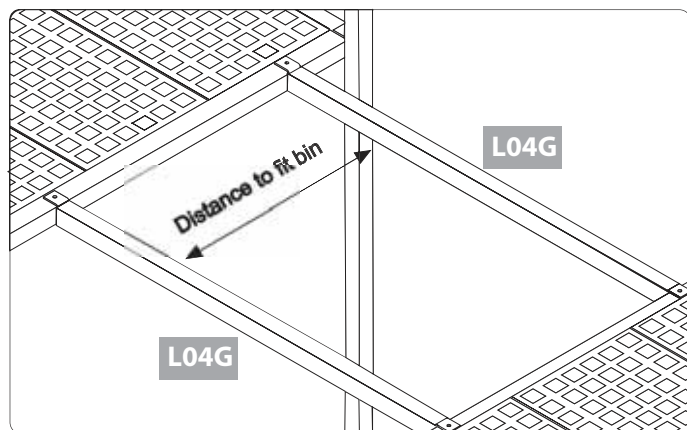
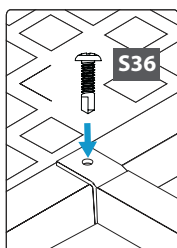
**17.3B** Secure each connector with one S36 screw.



**NOTE:** A cordless drill with a phillips head bit is recommended.

Profile	QTY	Connector	QTY	Screw	QTY
 #L04G	2	 #S37	4	 #S02	4
				 #S36	4





# Systems Trading Corporation

## 8' x 8' Easy-Grow Greenhouse

### Assembly Instructions

If you need any help or have missing or damaged parts,  
please contact us.

### Systems Trading Corporation

450 7th Avenue Suite 2809, New York, NY 10123

Customer Service: (877) 407-9100 ext 1

Email: [customerservice@stcaustin.com](mailto:customerservice@stcaustin.com)



Please keep this manual in a safe place for reference.